

SECTION A-A

SECTION B-B

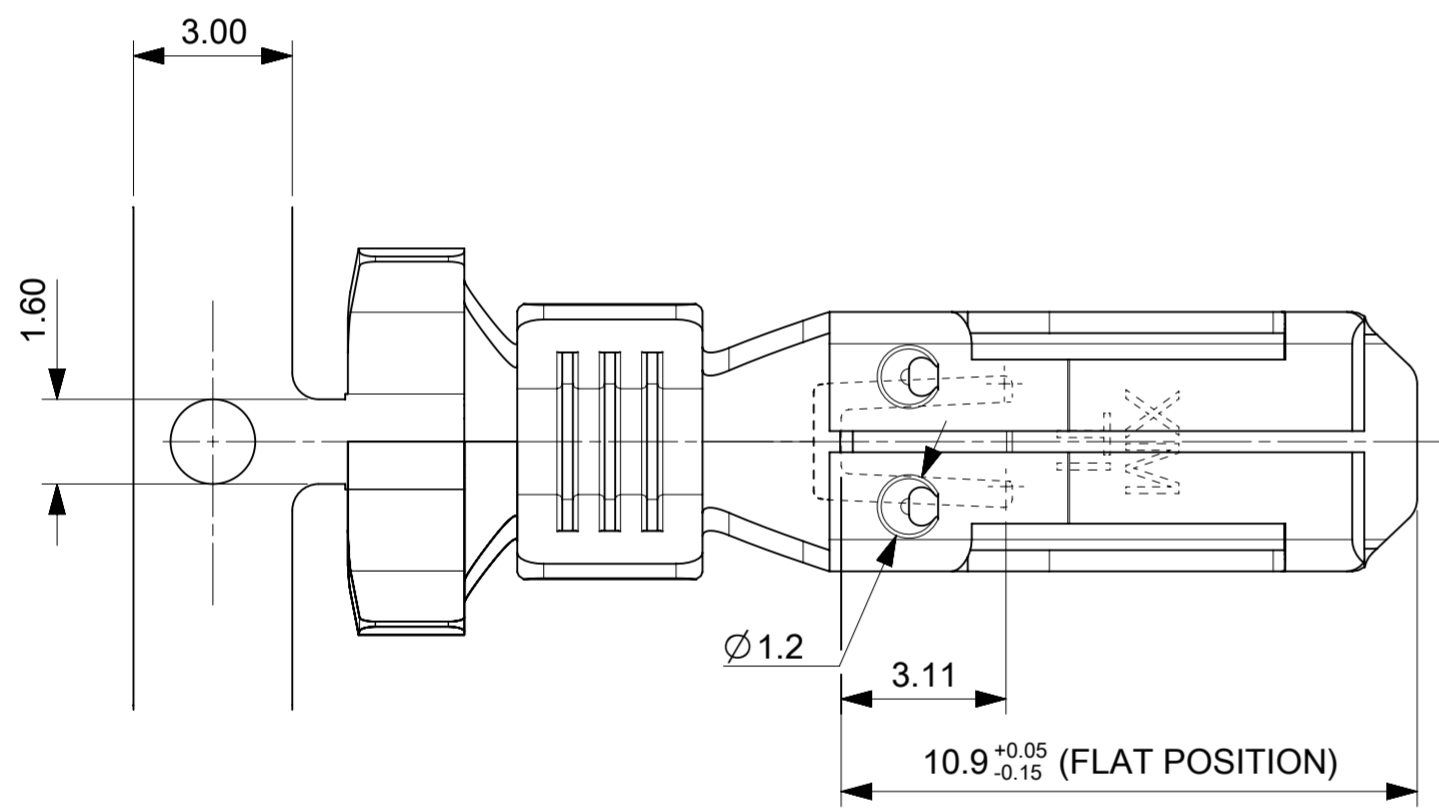

P/N	PLATING	MATERIAL	WIRE RANGE	INS. RANGE	DIMENSION				
					A	B	C	D	E
94518-0100	PLAIN	BRASS	0.5 - 1.0	2.2 - 2.8	4.5	4.5	3.0	3.0	/
94518-0101	TIN								
94518-0200	PLAIN	BRASS	1.0 - 2.5 FOR SINGLE DOUBLE CABLES	2.6 - 3.8	5.5	5.5	4.1	4.3	/
94518-0201	TIN								
94518-0400	PLAIN	BRASS	1.5 - 3.0 FOR DOUBLE CABLES	-	7.3	5.1	5.2	4.0	1.8
94518-0401	TIN								
94518-0300	PLAIN	BRASS	4.0	3.4 - 3.7	5.5	5.5	5.0	5.1	/
94518-0301	TIN								

DIRECTION OF UNREELING

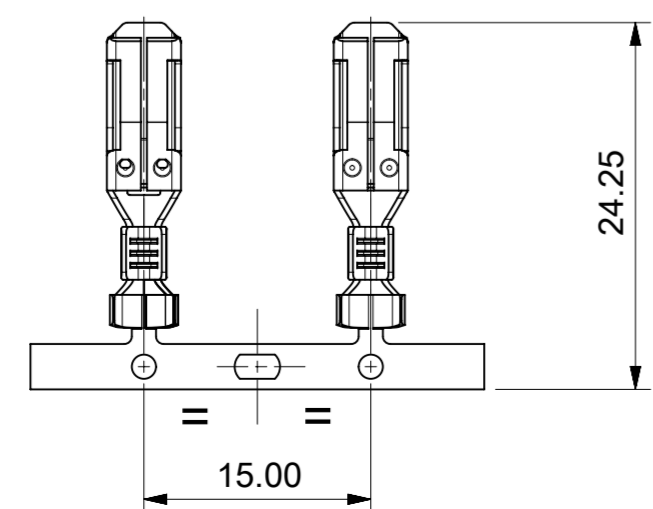
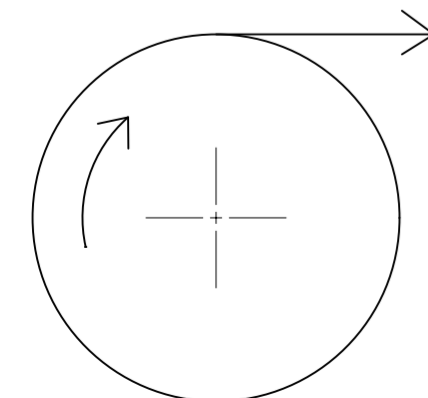

PACKAGING: REFER 945180001-PK

STD. DESCRIPTION: HNF TERM (material-plating-wire gauge)

FUNCTIONAL SYMBOLS $F_A = 0$ $F_C = 0$ $F_P = 0$ DIVISIONAL SYMBOLS	THIS DRAWING CONTAINS INFORMATION THAT IS PROPRIETARY TO MOLEX ELECTRONIC TECHNOLOGIES, LLC AND SHOULD NOT BE USED WITHOUT WRITTEN PERMISSION		molex RAST 5 CRIMP TERMINAL		
	DIMENSION UNITS: mm	SCALE: 7:1			
	GENERAL TOLERANCES (UNLESS SPECIFIED)		EC NO: 657968		
	ANGULAR TOL ± 2.0°		DRWN: SCV 2021/03/09		
4 PLACES ±		CHK'D: MBN02 2021/03/15			
3 PLACES ±		APPR: SDEVITT 2021/03/22			
2 PLACES ± 0.1		INITIAL REVISION:			
1 PLACE ± 0.2		DRWN: AKABADI 2021/01/07			
0 PLACES ±		APPR: SDEVITT 2021/02/25			
DRAFT WHERE APPLICABLE MUST REMAIN WITHIN DIMENSIONS		THIRD ANGLE PROJECTION	DRAWING: A2-SIZE	SERIES: 94518	DOCUMENT NUMBER: 945180001
					DOC TYPE: PSD
					DOC PART: 000
					REVISION: A1
					MATERIAL NUMBER: SEE TABLE
					CUSTOMER: GENERAL MARKET
					SHEET NUMBER: 1 OF 1

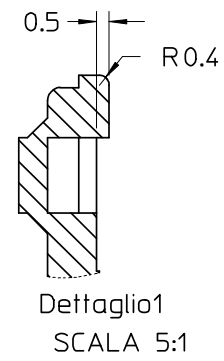
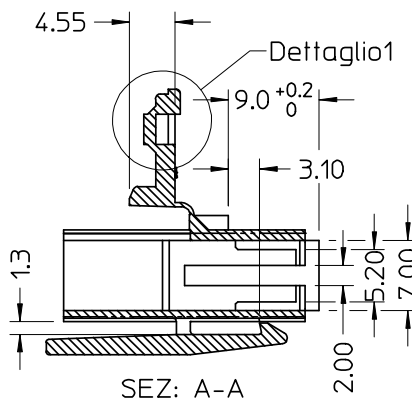
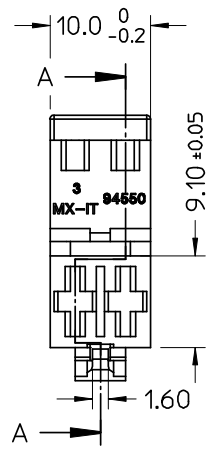

CONFIGURAZIONE POLARIZZAZIONI
POLARIZATION CONFIGURATION

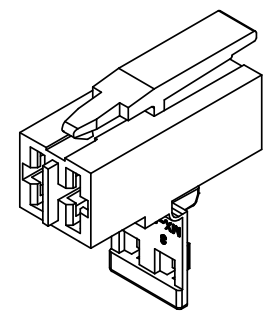
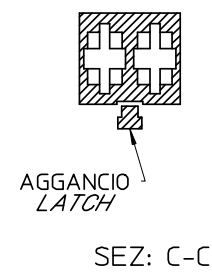

- NOTE:
- USATO CON TERMINALI 94518-0XXX E 94549-0XXX
 - SPECIFICA DI RIFERIMENTO PER IL CONNETTORE PS-94550-001
 - PER CARATTERISTICHE DI CRIMPATURA RIF. SD-94518-005 E SD-94549-001
 - FORZA DI DISACCOPIAMENTO CONNETTORE (TRAZIONANDO DAI CAVI SENZA AZIONARE L'AGGANCIO): 40 N MIN.
 - SPESSORE MINIMO PARETI CONNETTORE 0.40 mm.

- NOTE:
- USED WITH TERMINALS 94518-0XXX AND 94549-0XXX
 - REFER TO PS-94550-001 FOR CONNECTOR SPECIFICATION
 - REFER TO SD-94518-005 AND SD-94549-001 FOR CRIMPING CHARACTERISTICS
 - CONNECTOR DISENGAGEMENT FORCE (PULLING BY THE WIRES, WITHOUT ACTUATING THE LATCH): 40 N MIN.
 - MINIMUM CONNECTOR WALL THICKNESS 0.40 mm

CONFEZIONE: Box da 3500 Pz.
PACKAGING: 3500 pcs in carton box

P/N	MATERIAL/COLOR
94550-8202	NYLON 6.6 V2 NATURAL
94550-4202	NYLON 6.6 GWT 750 °C sec.IEC 60335-1 TEST METHOD IEC 60695-2-11 NATURAL

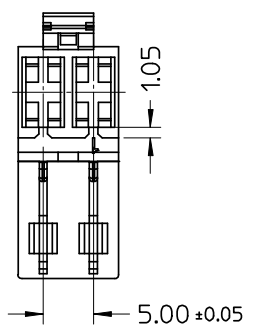
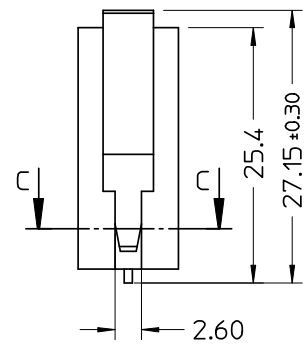
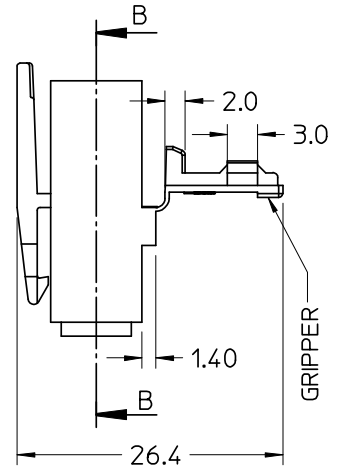
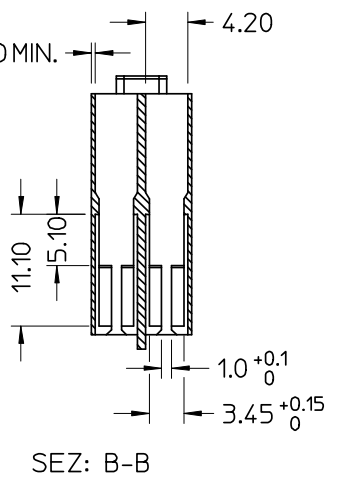
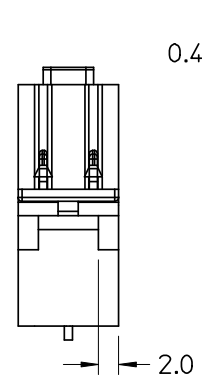

SPQ =3500

Std. Descr: "HSG W/SEC LOCK AND EXT LATCH 2 CKT _____ COLOR"

EC NO: Z2006-0211 DRWN: FGOTTARD 2006/06/05 CHKD: RSANDANO 2006/06/05 APPR: GZUIN 2006/06/07	QUALITY SYMBOLS	GENERAL TOLERANCES (UNLESS SPECIFIED)	SCALE 2:1	DESIGN UNITS METRIC	FIRST ANGLE PROJECTION	REVISE ON CAD ONLY
	DESCRIPTION ▲ = 0 ▽ = 0	mm	INCH	DIMENSION STYLE MM ONLY		TITLE HSG 2 CKT WITH SEC. LOCK AND EXTERNAL LATCH
		4 PLACES ± --- ± ---				
		3 PLACES ± --- ± ---		DRAWN BY DATE FGOTTARD 2004/03/08		
2 PLACES ± 0.10 ± ---		CHECKED BY DATE RSANDANO 2004/03/08				
		1 PLACE ± 0.2 ± ---		APPROVED BY DATE GZUIN 2004/03/08	MOLEX MOLEX INCORPORATED MATERIAL NO. SEE TABLE DOCUMENT NO. SD-94550-012 SHEET NO. 1 OF 1	
		ANGULAR ± 2 °		THIS DRAWING CONTAINS INFORMATION THAT IS PROPRIETARY TO MOLEX INCORPORATED AND SHOULD NOT BE USED WITHOUT WRITTEN PERMISSION		
		DRAFT WHERE APPLICABLE				
		MUST REMAIN WITHIN DIMENSIONS				