

LCD Keypad Shield For Arduino SKU: DFR0009

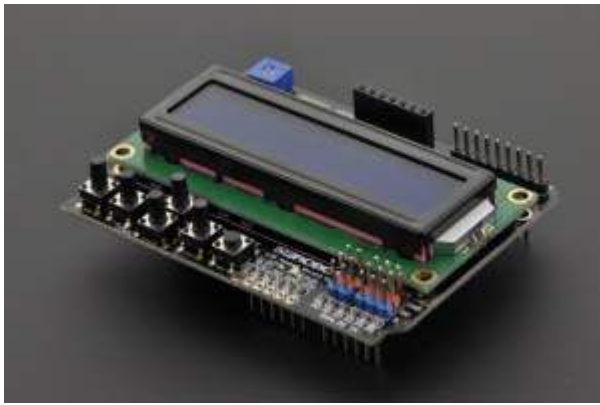

1602 LCD Keypad Shield For Arduino

Contents

- 1 Introduction
- 2 Specification
- 3 Pinout
- 4 Library Explanation
 - 4.1 Function Explanation
- 5 Tutorial
 - 5.1 Example 1
 - 5.2 Example 2
 - 5.2.1 Connction Diagram
 - 5.2.2 Sample code
 - 5.2.3 Result
- 6 Trouble shooting
- 7 More

Introduction

This is a very popular LCD Keypad shield for Arduino or Freeduino board. It includes a 2x16 LCD display and 6 momentary push buttons. Pins 4, 5, 6, 7, 8, 9 and 10 are used to interface with the LCD. Analog Pin 0 is used to read the push buttons. The LCD shield supports contrast adjustment and backlight on/off functions. It also expands analog pins for easy analog sensor reading and display.

The LCD Keypad shield is developed for Arduino compatible boards, to provide a user-friendly interface that allows users to go through the menu, make selections etc. It consists of a 1602 white character blue backlight LCD. The keypad consists of 5 keys — select, up, right, down and left. To save the digital IO pins, the keypad interface uses only one ADC channel. The key value is read through a 5 stage voltage divider.

Specification

- Operating Voltage:5V
- 5 Push buttons to supply a custom menu control panel
- RST button for resetting arduino program
- Integrate a potentiometer for adjusting the backlight
- Expanded available I/O pins
- Expanded Analog Pinout with standard DFRobot configuration for fast sensor extension
- Dimension: 80 x 58 mm
-

Pinout

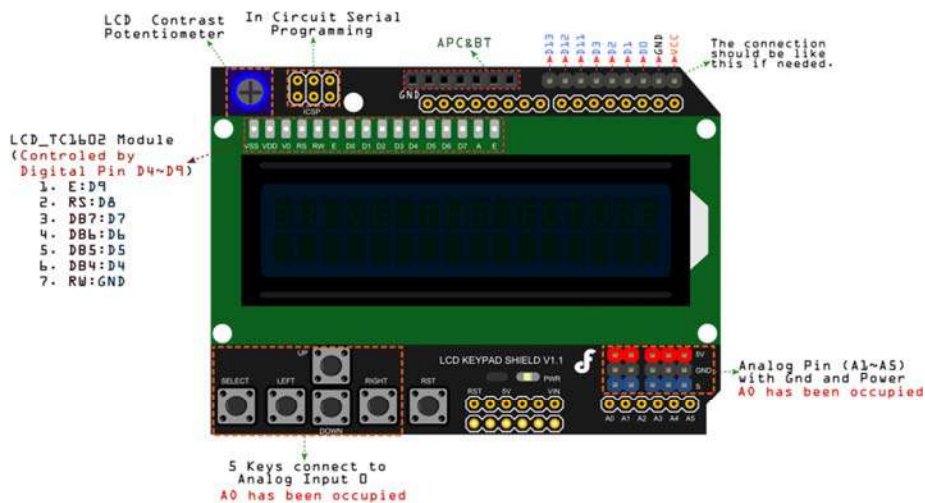

Instruction for D4 To D10 and Analog Pin 0

Pin	Function	Instruction
Digital 4(D4)		
Digital 5(D5)	D4~D7 are used as DB4~DB7	Four high order bidirectional tristate data bus pins. Used for data transfer and receive between the MPU and the LCD.
Digital 6(D6)		
Digital 7(D7)		
Digital 8(D8)	RS	Choose Data or Signal Display
Digital 9(D9)	Enable	Starts data read/write
Digital 10(D10)	LCD Backlight Control	
Analog 0(A0)	Button select	Select, up, right, down and left

Library Explanation

Function Explanation

LiquidCrystal(rs, enable, d4, d5, d6, d7)

Creates a variable of type LiquidCrystal. The display can be controlled using 4 or 8 data lines. If the former, omit the pin numbers for d0 to d3 and leave those lines unconnected. The RW pin can be tied to ground instead of connected to a pin on the Arduino; if so, omit it from this function's parameters. for example:

```
LiquidCrystal lcd(8, 9, 4, 5, 6, 7);
```

lcd.begin(cols, rows)

Initializes the interface to the LCD screen, and specifies the dimensions (width and height) of the display. begin() needs to be called before any other LCD library commands. for example:

```
lcd.begin(16, 2);
```

lcd.setCursor(col,row)

Set the location at which subsequent text written to the LCD will be displayed. for example:

```
lcd.setCursor(0,0);
```

lcd.print(data)

Prints text to the LCD. for example:

```
lcd.print("hello, world!");
```

lcd.write(data)

Write a character to the LCD.

More function can see:

- [LiquidCrystal library](#)

Tutorial

Example 1

This example will test the LCD panel and the buttons. When you push the button on the shield, the screen will show the corresponding one.

Connection: Plug the LCD Keypad to the UNO (or other controllers)

```
/******  
*****  
  
    Mark Bramwell, July 2010  
  
    This program will test the LCD panel and the buttons. When you push the butt  
on on the shield,  
    the screen will show the corresponding one.  
  
    Connection: Plug the LCD Keypad to the UNO (or other controllers)  
  
*****/  
  
#include <LiquidCrystal.h>  
  
LiquidCrystal lcd(8, 9, 4, 5, 6, 7);           // select the pins used on the  
LCD panel  
  
// define some values used by the panel and buttons  
int lcd_key    = 0;  
int adc_key_in = 0;  
  
#define btnRIGHT 0  
#define btnUP    1  
#define btnDOWN  2  
#define btnLEFT  3  
#define btnSELECT 4
```

```

#define btnNONE    5

int read_LCD_buttons() {           // read the buttons
    adc_key_in = analogRead(0);     // read the value from the sensor

    // my buttons when read are centered at these values: 0, 144, 329, 504, 7
    41
    // we add approx 50 to those values and check to see if we are close
    // We make this the 1st option for speed reasons since it will be the mos
    t likely result

    if (adc_key_in > 1000) return btnNONE;

    // For V1.1 us this threshold
    if (adc_key_in < 50)    return btnRIGHT;
    if (adc_key_in < 250)  return btnUP;
    if (adc_key_in < 450)  return btnDOWN;
    if (adc_key_in < 650)  return btnLEFT;
    if (adc_key_in < 850)  return btnSELECT;

    // For V1.0 comment the other threshold and use the one below:
    /*
        if (adc_key_in < 50)    return btnRIGHT;
        if (adc_key_in < 195)  return btnUP;
        if (adc_key_in < 380)  return btnDOWN;
        if (adc_key_in < 555)  return btnLEFT;
        if (adc_key_in < 790)  return btnSELECT;
    */

    return btnNONE;               // when all others fail, return this.
}

void setup() {
    lcd.begin(16, 2);             // start the library
    lcd.setCursor(0,0);          // set the LCD cursor position
}

```

```

    lcd.print("Push the buttons"); // print a simple message on the LCD
}

void loop(){
    lcd.setCursor(9,1);           // move cursor to second line "1" and 9 spaces over
    lcd.print(millis()/1000);     // display seconds elapsed since power-up

    lcd.setCursor(0,1);          // move to the beginning of the second line
    lcd_key = read_LCD_buttons(); // read the buttons

    switch (lcd_key){            // depending on which button was pushed, we perform an action

        case btnRIGHT:{         // push button "RIGHT" and show the word on the screen
            lcd.print("RIGHT ");
            break;
        }
        case btnLEFT:{          // push button "LEFT" and show the word on the screen
            lcd.print("LEFT ");
            break;
        }
        case btnUP:{            // push button "UP" and show the word on the screen
            lcd.print("UP ");
            break;
        }
        case btnDOWN:{          // push button "DOWN" and show the word on the screen
            lcd.print("DOWN ");
            break;
        }
        case btnSELECT:{        // push button "SELECT" and show the word on the screen
            lcd.print("SELECT");

```

```
        break;
    }
    case btnNONE: {
        lcd.print("NONE "); // No action will show "None" on the screen
        break;
    }
}
}
```

Example 2

This example shows that reads an analog input on pin 1, prints the result to the LCD. This program takes the temperature sensor LM35 for example.

What you need

1. DFRduino UNO R3
2. LCD Keypad Shield For Arduino
3. Analog Linear Temperature Sensor

Connection:

Plug the LCD Keypad to the UNO(or other controllers)

Temperture sensor: S(blue) -- A1()

Note: A0 has been occupied.

VCC(red) -- VCC

GND(black) -- GND

Tricks for changing sensor cable pin mapping

Connction Diagram

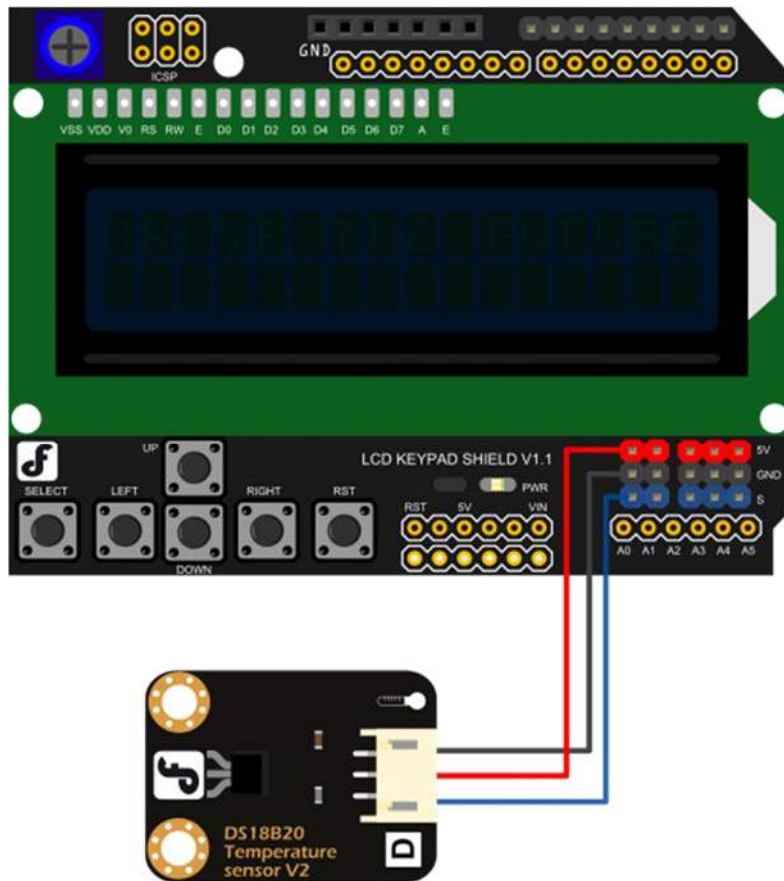

Sample code

```
/******
```

Description:

*Reads an analog input on pin 1, prints the result to the LCD.
This program takes the temperture sensor LM35 for example.*

Connection:

Plug the LCD Keypad to the UNO(or other controllers)

Temperture sensor:

S(blue) -- A1()

Note: A0 has been occupied.

VCC(red) -- VCC

```

GND(black) -- GND

*****/

#include <LiquidCrystal.h>

LiquidCrystal lcd(8, 9, 4, 5, 6, 7);    // select the pins used on the LC
D panel

unsigned long tepTimer ;

void setup(){
    lcd.begin(16, 2);                    // start the library
}

void loop(){
    lcd.setCursor(0, 0);                 // set the LCD cursor position
    int val;                              // variable to store the value coming
from the analog pin
    double data;                          // variable to store the temperature
value coming from the conversion formula
    val=analogRead(1);                    // read the analog in value:
    data = (double) val * (5/10.24);      // temperature conversion formula

    if(millis() - tepTimer > 500){      // output a temperature value per
500ms
        tepTimer = millis();

        // print the results to the lcd
        lcd.print("T: ");
        lcd.print(data);
        lcd.print("C");
    }
}

```

Result

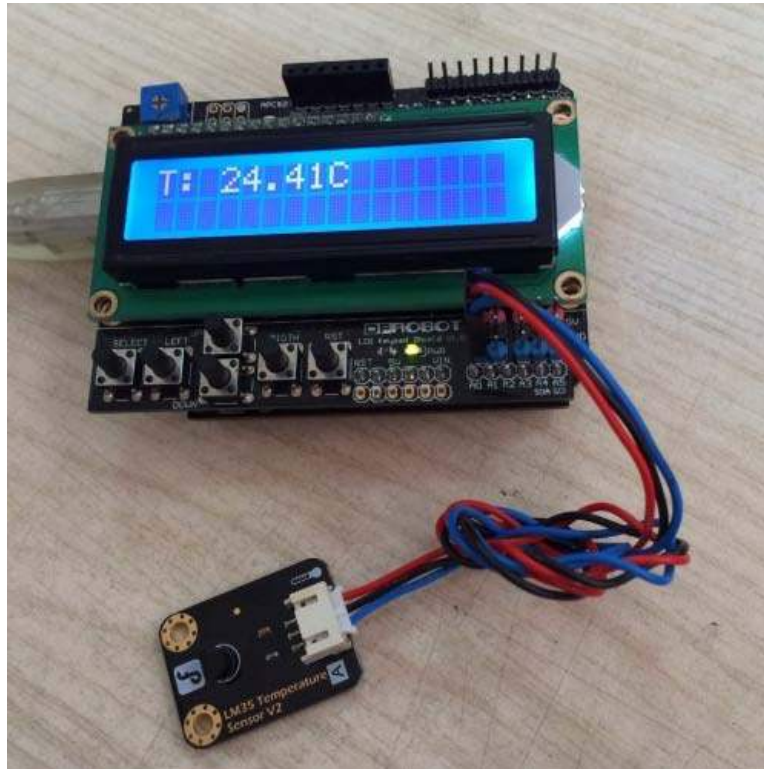

Trouble shooting

Q1. Why my LCD keypad cannot **display anything** on the Intel Edison while all right on Romeo?

A1: It works well if uploaded by Arduino 1.5.3 version, however, the latest 1.6.* have discard pin Definition **for Edison**. So you have to add **pinMode()**; into the setup() like this:

```
void setup() {  
  for(int i=4;i<10;i++){  
    pinMode(i,OUTPUT);  
  }  
  lcd.begin(16, 2); // set up the LCD's number of columns and rows  
}
```

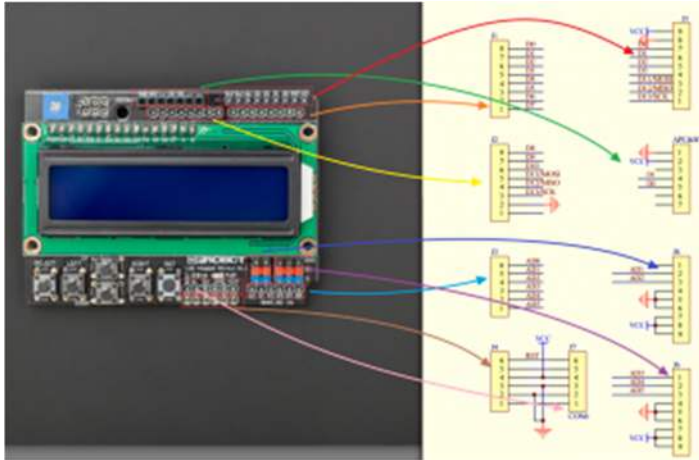

For A2. Pin mapping on schematic

Q2. I do not understand your schematic. There are too many connectors illustrated than are actually on the shield. Could you show me a mapping?

A2: The J1-J8 include the both the user interface, i.e. Analog pins, APC220(Serial) pins, Digital pins, and the pins connected with the lower Arduino card, e.g. Uno/ Leonardo. Here is a simple mapping picture.

For any questions and more cool ideas to share, please visit **DFRobot Forum**