

Burst Triple-Mode PWM Controller with Integrated HV Start-up Device for Zero Power Monitor Application

General Description

The R7779 is a high-performance current mode PWM controller with integrated HV start-up device inside. During start-up, a current source through integrated HV device to charge VDD capacitor for quick start-up while it dissipates no loss in normal operation.

The R7779 provides the users a superior AC/DC power application of higher efficiency, low external component counts, and low cost solution. It features frequency jitter, Under Voltage LockOut (UVLO), Leading Edge Blanking (LEB), internal slope compensation in the tiny SOP-8 package. It offers complete protection coverage with Over Temperature Protection (OTP), Over Load Protection (OLP) and Over Voltage Protection (OVP).

Moreover, it also provides a special interface for zero power application when the converter is in sleeping mode. EN/DIS pin receives ON/OFF signal from secondary scalar controller. During turning off, the controller will be shutdown completely with pretty low power consumption.

Features

- Integrated HV Start-up Device
- UVLO : 9V/16.5V
- Current Mode Control
- Built-in 65kHz Operation Frequency
- Jittering Frequency
- Internal PWM Leading Edge Blanking
- Internal Slope Compensation
- Compensated Burst Triple-Mode PWM
- Cycle-by-Cycle Current Limit
- Internal Auto Recovery OVP
- Internal Auto Recovery OLP
- Internal Auto Recovery OTP
- Secondary Rectifier Short Protection
- Soft Driving for Reducing EMI Noise
- High Noise Immunity
- RoHS Compliant and Halogen Free

Applications

- Switching AC/DC Adaptor and Battery Charger
- TV and Monitor Application

Typical Application Circuit

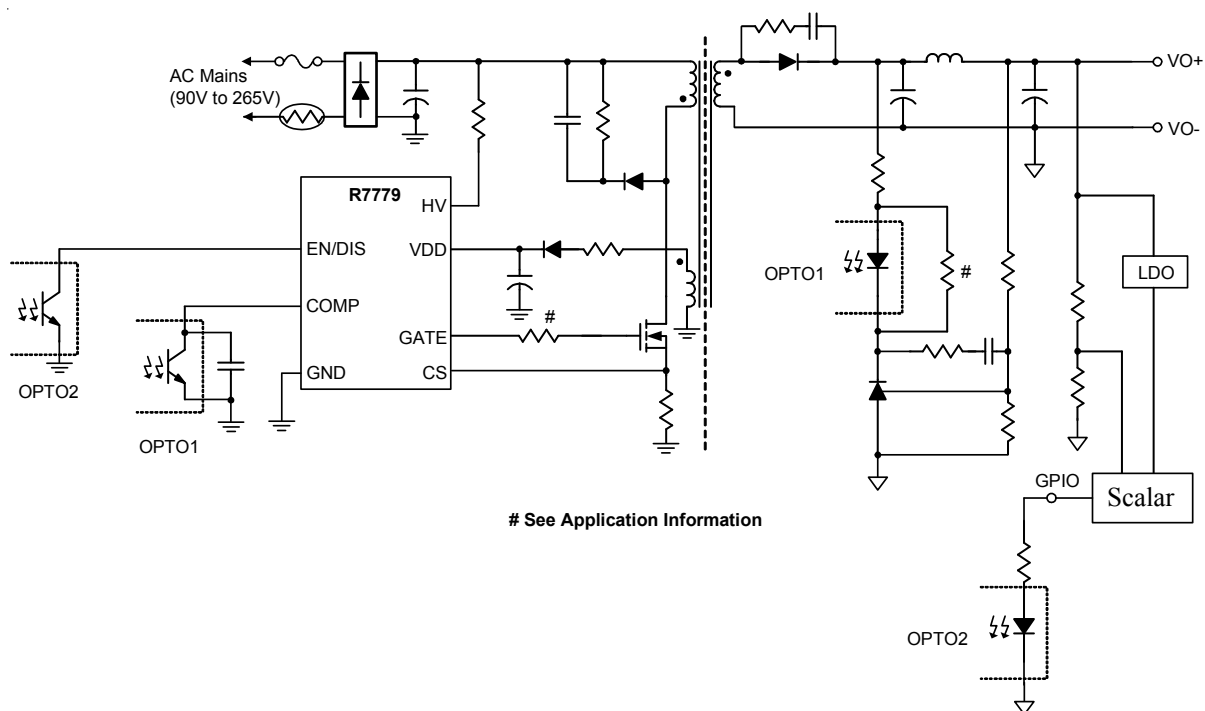

Ordering Information

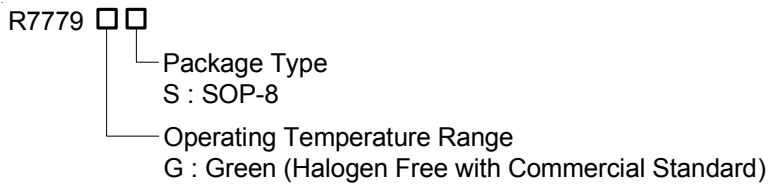

Note :

Richpower Green products are :

- ▶ RoHS compliant and compatible with the current requirements of IPC/JEDEC J-STD-020.
- ▶ Suitable for use in SnPb or Pb-free soldering processes.

Marking Information

For marking information, contact our sales representative directly or through a Richpower distributor located in your area, otherwise visit our website for detail.

Pin Configurations

(TOP VIEW)

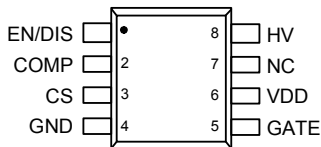

SOP-8

Functional Pin Description

Pin No.	Pin Name	Pin Function
1	EN/DIS	Enable function pin.
2	COMP	Voltage feedback pin. By connecting a opto-coupler to close control loop and achieve the regulation.
3	CS	Current sensing pin.
4	GND	Ground.
5	GATE	Gate drive output to drive the external MOSFET.
6	VDD	Power supply pin.
7	NC	No connection.
8	HV	500V high voltage device for start-up.

Function Block Diagram

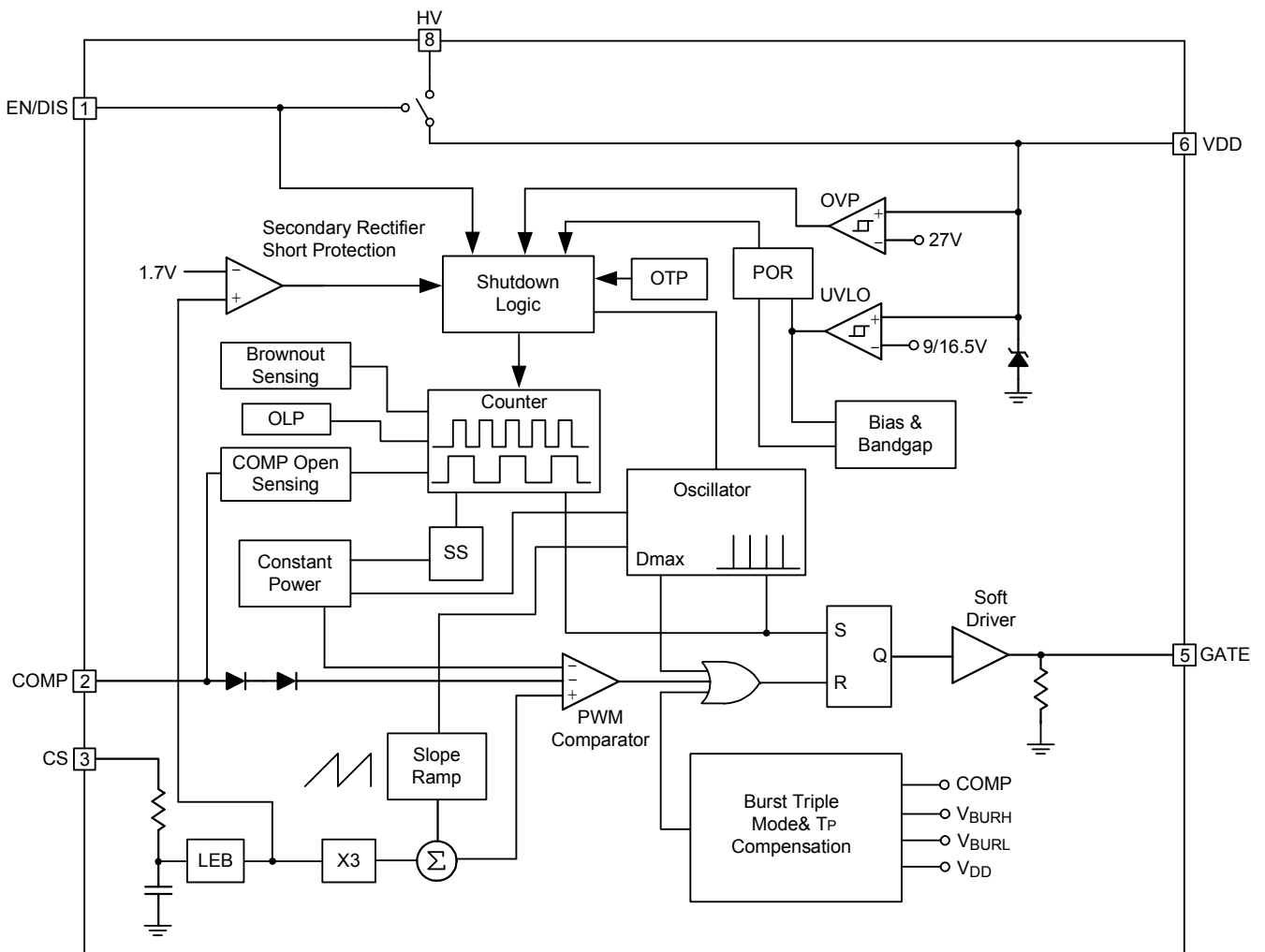

Absolute Maximum Ratings (Note 1)

- HV Pin ----- -0.3V to 500V
- Supply Input Voltage, V_{DD} ----- -0.3V to 30V
- GATE Pin ----- -0.3V to 20V
- EN/DIS, COMP, CS Pin ----- -0.3V to 6.5V
- Power Dissipation, P_D @ $T_A = 25^\circ\text{C}$
 SOP-8 ----- 0.4W
- Package Thermal Resistance (Note 2)
 SOP-8, θ_{JA} ----- 160°C/W
- Junction Temperature ----- 150°C
- Lead Temperature (Soldering, 10 sec.) ----- 260°C
- Storage Temperature Range ----- -65°C to 150°C
- ESD Susceptibility (Note 3)
 HBM (Human Body Mode) ----- 4kV
 MM (Machine Mode) ----- 200V

Recommended Operating Conditions (Note 4)

- Supply Input Voltage, V_{DD} ----- 12V to 25V
- Ambient Temperature Range ----- -40°C to 85°C

Electrical Characteristics

($V_{DD} = 15\text{V}$, $T_A = 25^\circ\text{C}$, unless otherwise specified)

Parameter	Symbol	Conditions	Min	Typ	Max	Unit
HV Section						
HV start up current	I_{JEFT_ST}	$V_{DD} < V_{TH_ON}$, HV = 500V	1	--	–	mA
Off State Leakage Current		$V_{DD} = V_{TH_OFF}$, HV = 500V	--	--	25	μA
VDD Section						
On Threshold Voltage	V_{TH_ON}		15.5	16.5	17.5	V
Off Threshold Voltage	V_{TH_OFF}		8	9	10	V
V_{DD} Zener Clamp	V_Z		29	--	–	V
Operating Current	I_{DD_OP}	$V_{DD} = 15\text{V}$, 65kHz COMP pin, GATE pin open	--	550	1000	μA
VDD Holdup Mode End Point	V_{DD_HYS}	$V_{COMP} < 1.6\text{V}$	--	10.5	–	V
VDD Holdup Mode Entry Point	V_{DD_LOW}	$V_{COMP} < 1.6\text{V}$	--	10	–	V
V_{DD} Over Voltage Protection Level	V_{OVP}		25.5	27	28.5	V

To be continued

Parameter	Symbol	Conditions	Min	Typ	Max	Unit
Oscillator Section						
Normal PWM Frequency	f _{OSC}		60	65	70	kHz
Maximum Duty Cycle	DCY _{MAX}		70	75	80	%
PWM Frequency Jitter Range	Δf		--	±7	--	%
PWM Frequency Jitter Period	T _{JIT}	For 65kHz	--	4	--	ms
Frequency Variation Versus V _{DD} Deviation	f _{DV}	V _{DD} = 12V to 25V	--	--	2	%
Frequency Variation Versus Temp. Deviation	f _{DT}	T _A = -30°C to 105°C	--	--	5	%
COMP Input Section						
Open Loop Voltage	V _{COMP_OP}	COMP pin open	5.5	5.75	6	V
COMP Open 56ms Protection	V _{COMP_56}		5.25	--	--	V
COMP Open-loop Protection Delay Time	T _{OLP}		--	56	--	ms
Short Circuit COMP Current	I _{ZERO}	V _{COMP} = 0V	--	1.3	2.5	mA
Current-Sense Section						
Initial Current Limit Offset	V _{CSTH}		0.72	0.75	0.78	V
Leading Edge Blanking Time	T _{LEB}	(Note 5)	150	250	350	ns
Internal Propagation Delay Time	T _{PD}	(Note 5)	--	100	--	ns
Minimum On Time	T _{ON_MIN}		250	350	450	ns
GATE Section						
Gate Output Clamping Voltage	V _{CLAMP}	V _{DD} = 25V	--	14	--	V
Rising Time	T _R	V _{DD} = 15V, C _L = 1nF	--	125	--	ns
Falling Time	T _F	V _{DD} = 15V, C _L = 1nF	--	45	--	ns
EN/DIS Interface Section						
Enable Threshold	V _{EN_TH}		0.8	1	1.2	V
EN/DIS Pin Max Clamping Current			--	--	30	μA

Note 1. Stresses beyond those listed under “ Absolute Maximum Ratings” may cause permanent damage to the device. These are stress ratings only, and functional operation of the device at these or any other conditions beyond those indicated in the operational sections of the specifications is not implied. Exposure to absolute maximum rating conditions for extended periods may affect device reliability.

Note 2. θ_{JA} is measured in the natural convection at T_A = 25°C on a low effective single layer thermal conductivity test board of JEDEC 51-3 thermal measurement standard.

Note 3. Devices are ESD sensitive. Handling precaution is recommended.

Note 4. The device is not guaranteed to function outside its operating conditions.

Note 5. Leading edge blanking time and internal propagation delay time are guaranteed by design.

Typical Operating Characteristics

V_{TH_OFF} vs. Temperature

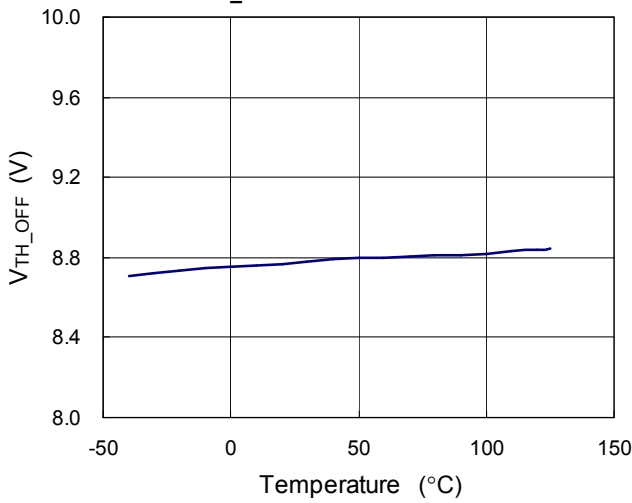

V_{TH_ON} vs. Temperature

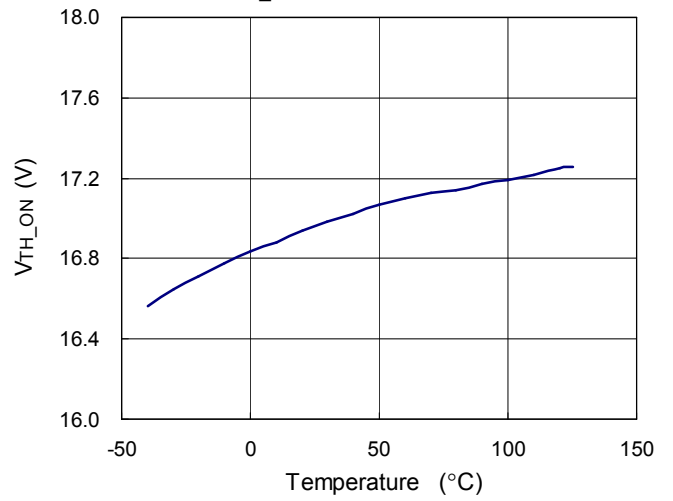

Oscillation Frequency (f_{OSC}) vs. Temperature

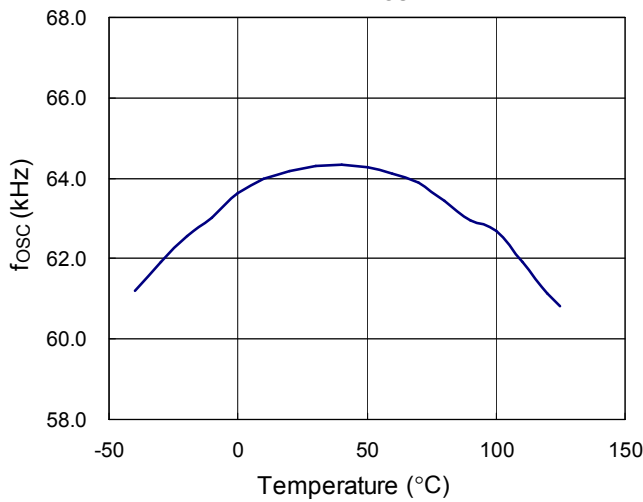

Gate Output Clamp Voltage (V_{CLAMP}) vs. V_{DD}

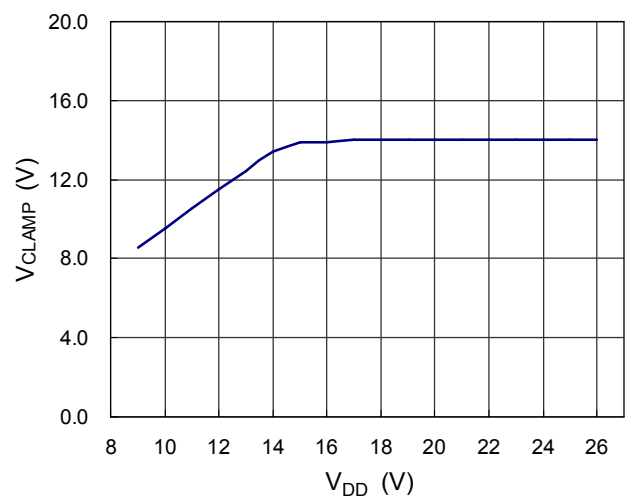

Operating Current (I_{DD_OP}) vs. V_{DD}

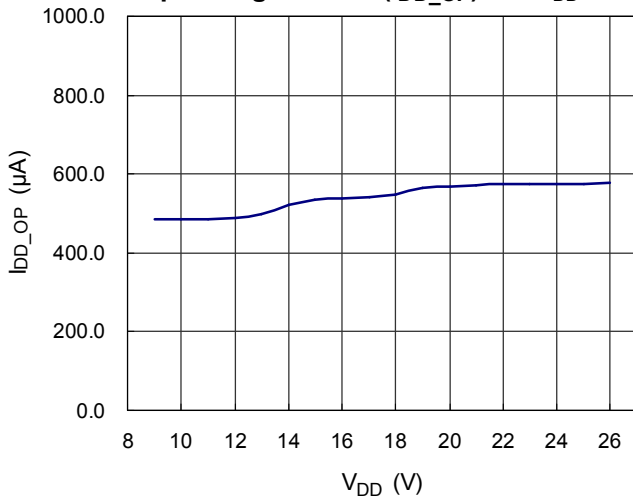

Oscillation Frequency (f_{OSC}) vs. V_{DD}

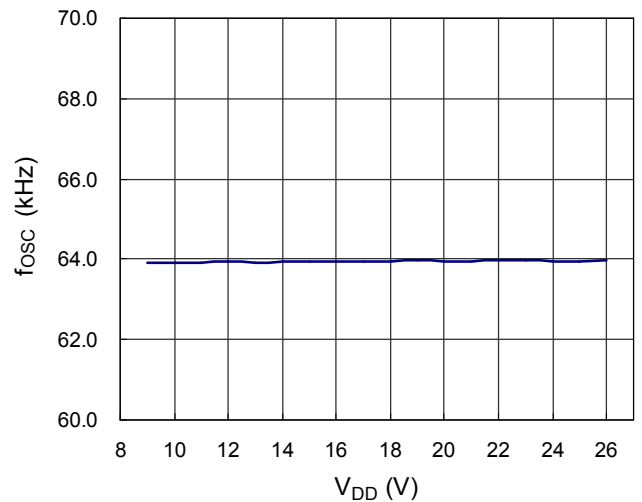

Gate Output Clamp Voltage (V_{CLAMP}) vs. Temperature

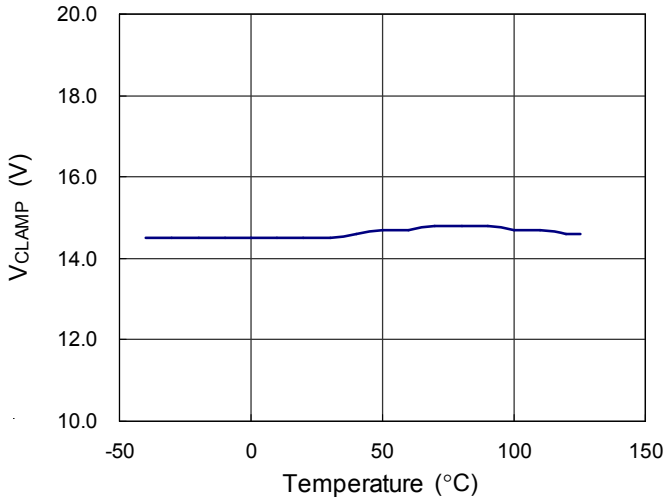

Comp Short Current (I_{ZERO}) vs. Temperature

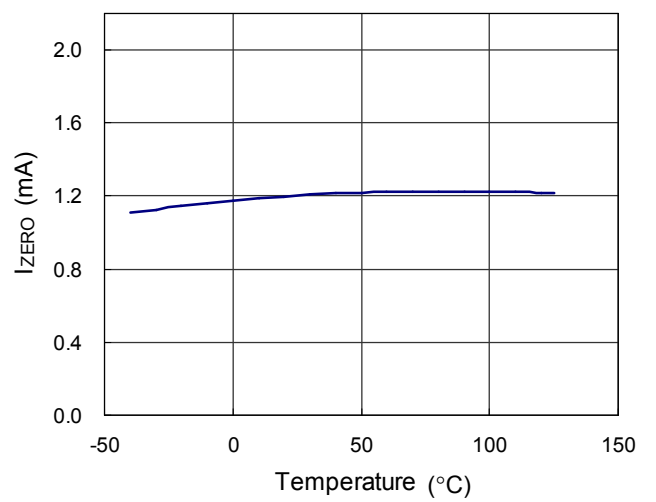

Comp Open Voltage (V_{COMP_OP}) vs. Temperature

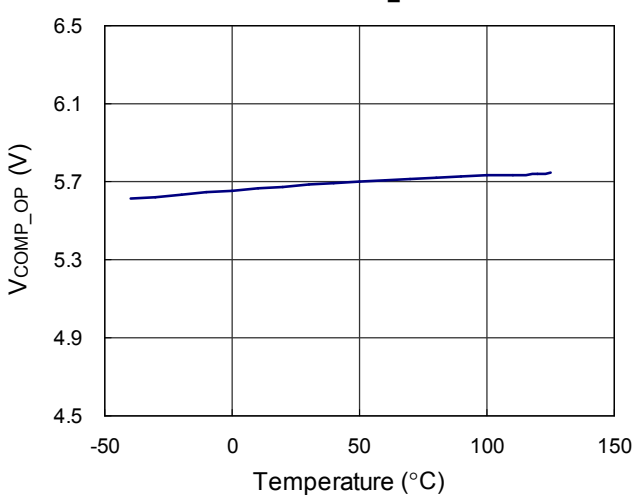

Over Voltage Protection Level (V_{OVP}) vs. Temperature

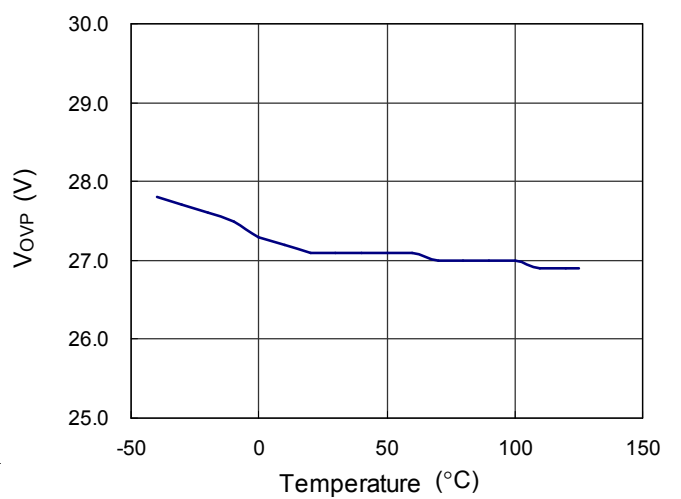

Initial Current Limit Offset (V_{CSTH}) vs. Temperature

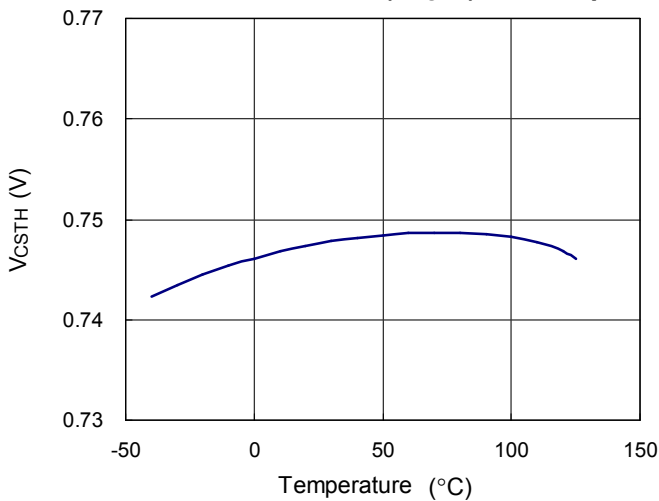

Operating Supply Current (I_{DD_OP}) vs. Temperature

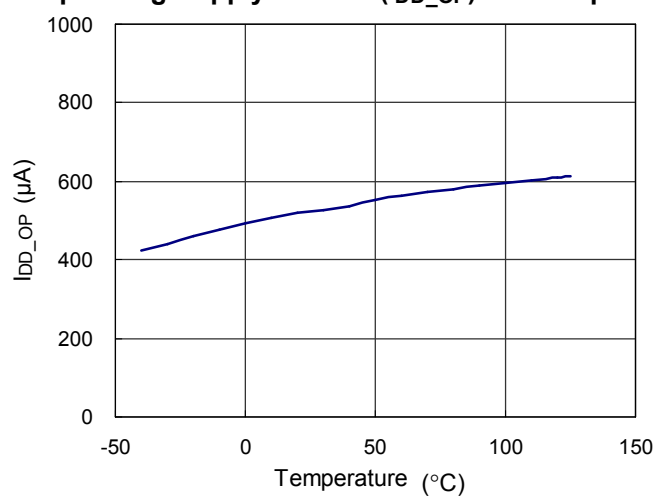

Enable Threshold Voltage (V_{EN_TH}) vs. Temperature

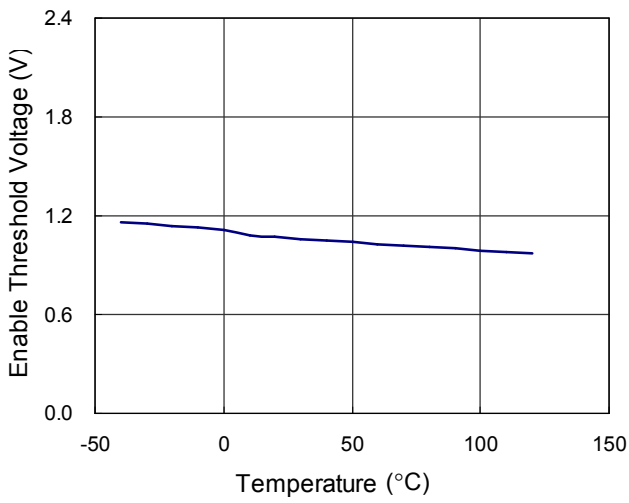

HV Startup Current vs. Temperature

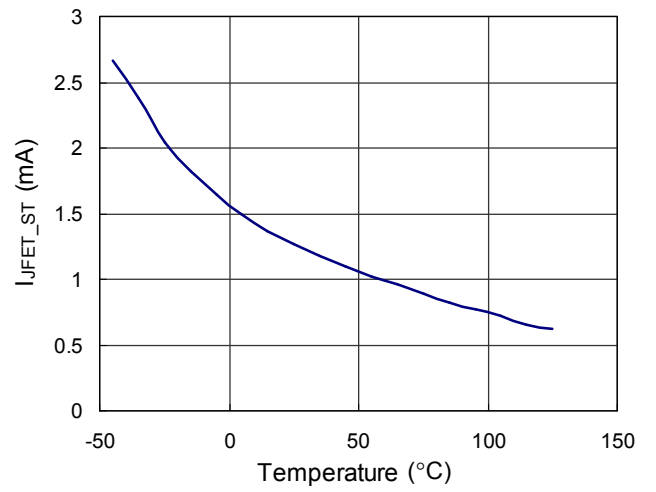

Startup Current vs. Temperature

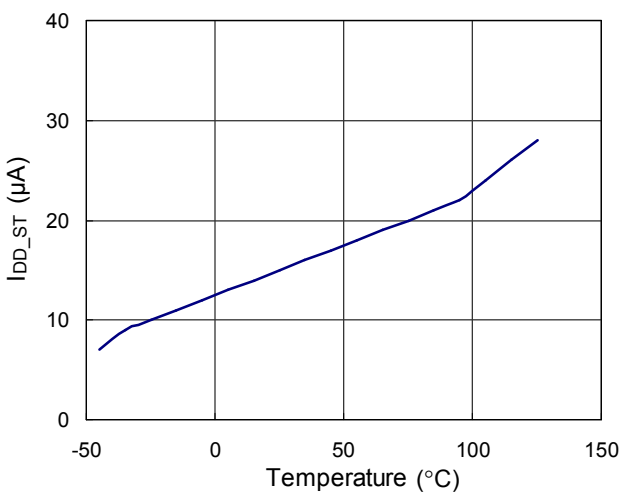

D_{MAX} vs. Temperature

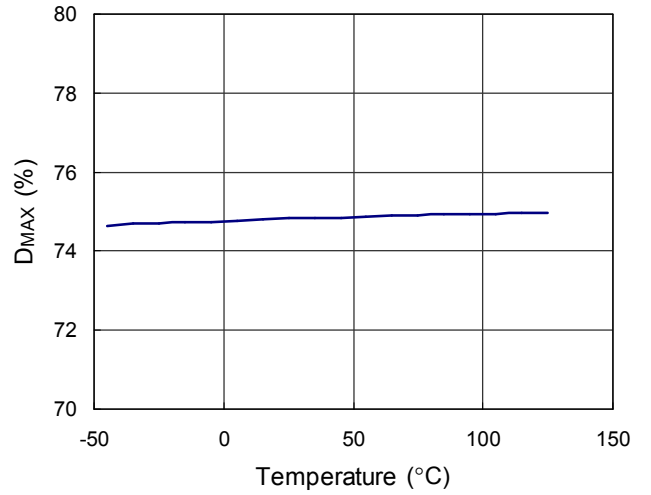

Application Information

The R7779 is specially designed for advanced monitor application. The proprietary ON/OFF control pin completely shuts down the controller after receiving downstream scalar signal from secondary side. (It achieves almost zero power under sleeping mode.)

HV Start-up Device

An in-house design 500V start-up device is integrated in the controller to further minimize loss and enhance performance. The HV start-up device will be turned on during start-up and be pulled low during normal operation. It guarantees fast start-up time and no power loss in this path after start-up.

Burst Triple Mode

The R7779 applies Burst Triple Mode for light load operation, because it's reliable, simple and has no patent infringement issues. Refer to Figure 1 for details.

- **PWM Mode** : For most of load condition, the circuit will run at traditional PWM current mode.
- **Burst Mode** : During light load, switching loss will dominate the power efficiency calculation. This mode can reduce the switching loss. When the output load

gets light, the feedback signal drops and touches V_{BURL} . Clock signal will be blanked and system ceases switching. After V_{OUT} drops and feedback signal goes back to V_{BURH} , the system will restart switching again. The burst mode entry points of high and low line are compensated to reduce audio noise at high line and get better efficiency at low line. This kind of operation, shown in the timing diagram of Figure 1.

- **VDD Holdup Mode** : When V_{DD} drops down to V_{DD} turn off threshold voltage, the system will be shut down. During shutdown period, controller does nothing to any load change and might cause V_{OUT} down. To avoid this, when V_{DD} drops to a setting threshold, 10V, the hysteresis comparator will bypass PWM and burst mode loop and force switching at a very low level to supply energy to VDD pin. VDD holdup mode is also improved to holdup V_{DD} by less switching cycles. This mode is very useful in reducing start-up resistor loss while still getting start up time in spec.. It's not likely for V_{DD} to touch UVLO turn off threshold during any light load condition. This will also makes bias winding design easier.

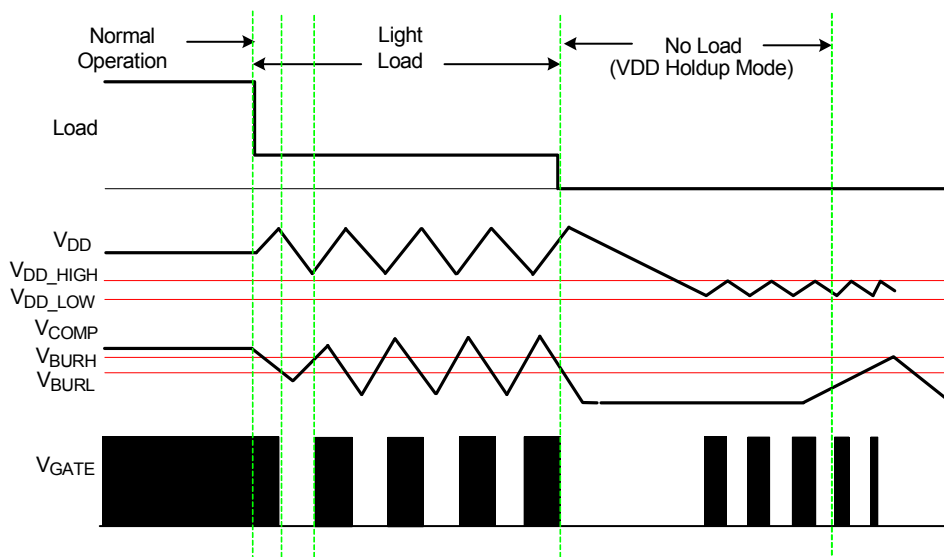

Figure 1. Burst Triple-Mode

Oscillator

To guarantee precise frequency, it is trimmed to 7% tolerance. It also generates slope compensation saw-tooth, 75% maximum duty cycle pulse and overload protection slope. It can typically operate at built-in 65kHz center frequency and feature frequency jittering function. Its jittering depth is 7% with about 4ms envelope frequency at 65kHz.

Gate Driver

A totem pole gate driver is fine tuned to meet both EMI and efficiency requirement in low power application. An internal pull low circuit is activated after pretty low V_{DD} to prevent external MOSFET from accidental turning-on during UVLO. #Typical application circuits are suggested adding resistance least 10Ω between GATE pin and MOSFET.

Tight Current Limit Tolerance

Generally, the saw current limit is applied to low cost flyback controller because of simple design. However, saw current limit is hard to test in mass production. Therefore, it's generally "guarantee by design". The variation of process and package will make its tolerance wider. It will lead to 20% to 30% variation when doing OLP test at certain line voltage. This will cause yield loss in power supply mass production. Through well foundry control, design and test/trim mode in final test, the R7779 current limit tolerance is tight enough to make design easier.

EN/DIS pin

The R7779 features an enable/disable circuit. If the voltage on the EN/DIS pin is greater than enable threshold voltage or EN/DIS pin is floating, the controller is enabled and switching will occur. If the voltage on the EN/DIS pin falls below enable threshold voltage, the controller will be shut down and consume almost zero power.

When the voltage of EN/DIS pin exceeds 1.2V or EN/DIS pin is floating, the system will be start-up. When the voltage of EN/DIS pin falls below 0.8V, the system will be shut down. For low standby power application, it's important to make current in this path as small as possible.

The deglitch delay time of the disable function is about

20 μ s. The internal bias current of EN/DIS is 2 μ A. For low power consumption, it's a high impedance pin. Therefore, proper layout is necessary for noise immunity. If capacitor is unavoidable, capacitor value should be carefully calculated and not to influence system operation.

Protection

The R7779 provides fruitful protection functions that intend to protect system from being damaged. All the protection functions can be listed as below.

- **Cycle-by-Cycle Current Limit** : This is a basic but very useful function and it can be implemented easily in current mode controller.
- **Over Load Protection** : Long time cycle-by-cycle current limit will lead to system thermal stress. To further protect system, system will be shut down after about 56ms (3840 clock cycles) in 67kHz operation. After shutdown, system will resume and behave as hiccup. Through our proprietary prolong turn off period as hiccup, the power loss and thermal during OLP will be averaged to an acceptable level over the ON/OFF cycle of the IC. This will last until fault is removed.

#It's highly recommended to add a resistor in parallel with opto-coupler. To provide sufficient bias current to make TL-431 regulate properly, 1.2k Ω resistor is suggested.
- **OVP** : Output voltage can be roughly sensed by VDD pin. If the sensed voltage reaches 27V threshold, system will be shut down after 20 μ s deglitch delay. This will last until fault is removed.
- **OTP** : Internal 110/140 $^{\circ}$ C hysteresis comparator will provide Over Temperature Protection (OTP) for controller itself. It's not suggested to use the function as precise OTP. OTP will not shut down system. It stops the system from switching until the temperature is under 110 $^{\circ}$ C. Meanwhile, if V_{DD} touches V_{DD} turn off threshold voltage, system will hiccup.
- **Feedback Open and Opto Short** : This will trigger OVP or 56ms delay protection. It depends on which one occurs first.
- **CS Pin Open Protection** : When CS pin is opened, the system will be shut down and into auto recovery

after couples of cycle. It could pass CS pin open test easier.

- Secondary Rectifier Short Protection** : As shown in Figure 2. The current spike during secondary rectifier short test is extremely high because of the saturated main transformer. Meanwhile, the transformer acts like a leakage inductance. During high line, the current in power FET is sometimes too high to wait for a 56ms OLP delay time. To offer better and easier protection design, the R7779 shuts down the controller after couples of cycles before fuse is blown up.

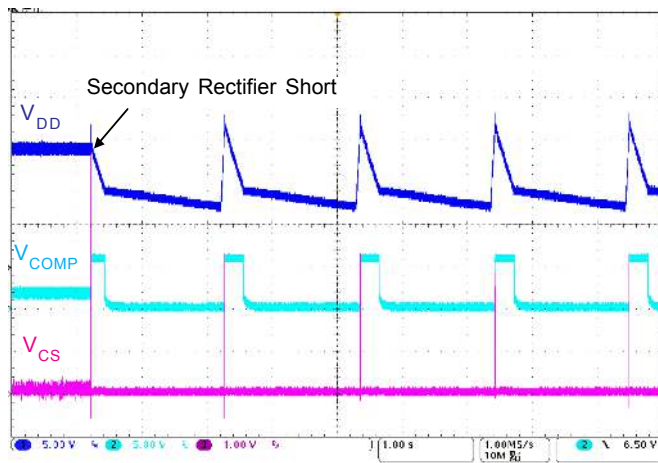

Figure 2. Secondary Rectifier Short Protection

PCB Layout Guide

A proper PCB layout can abate unknown noise interference and EMI issue in the switching power supply. Please refer to the guidelines when you want to design PCB layout for switching power supply:

The current path (1) from bulk capacitor, transformer, MOSFET, Rcs return to bulk capacitor is a huge high frequency current loop. It must be as short as possible to decrease noise coupling and kept a space to other low voltage traces, such as IC control circuit paths, especially. Besides, the path(2) from RCD snubber circuit to MOSFET is also a high switching loop, too. So keep it as small as possible. Furthermore, the path (3) from bulk capacitor to HV pin is a high voltage loop. It is highly recommended that EN/DIS control paths will be kept as far as possible from path (1), path (2) and path (3).

It is good for reducing noise, output ripple and EMI issue to separate ground traces of bulk capacitor(a), MOSFET(b), auxiliary winding(c) and IC control circuit (d). Finally, connect them together on bulk capacitor ground(a). The areas of these ground traces should be kept large.

Placing byass capacitor for abating noise on IC is highly recommended. The bypass capacitor should be placed as close to controller as possible.

To minimize reflected trace inductance and EMI minimize the area of the loop connecting the secondary winding, the output diode, and the output filter capacitor. In addition, apply sufficient copper area at the anode and cathode terminal of the diode for heatsinking. Apply a larger area at the quiet cathode terminal. A large anode area can increase high-frequency radiated EMI.

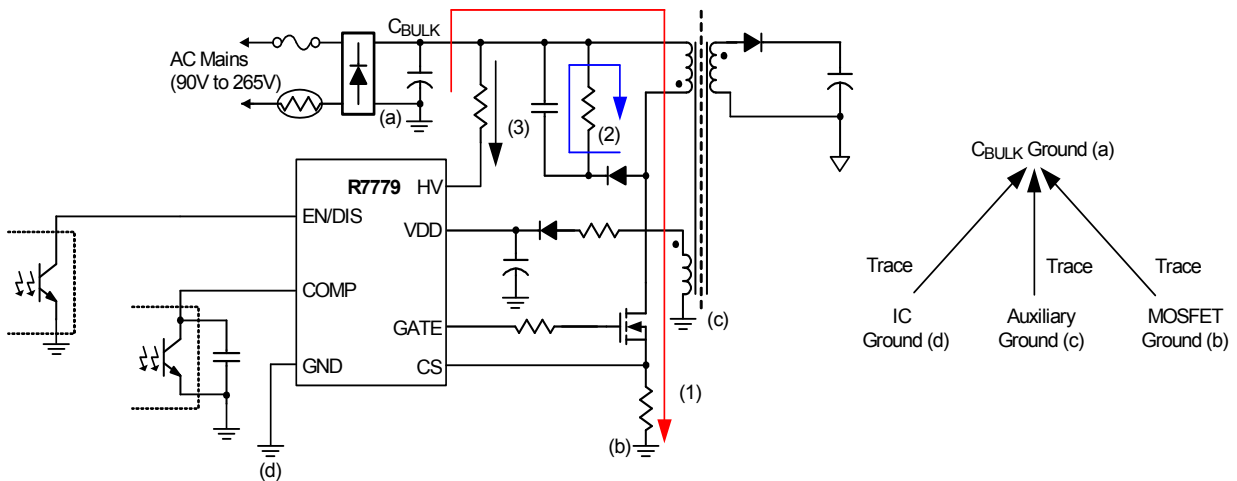

Outline Dimension

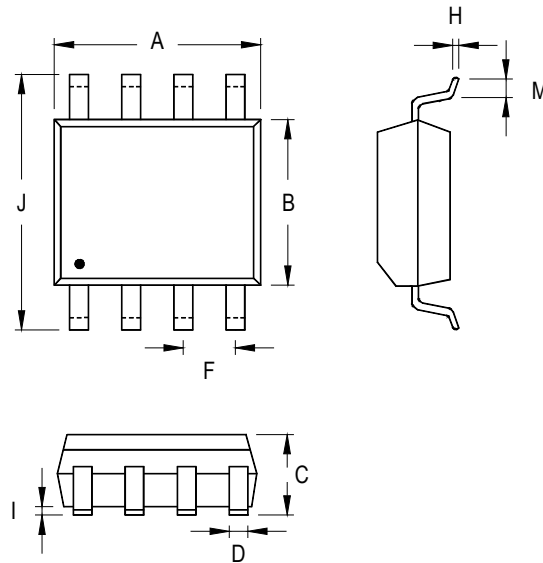

Symbol	Dimensions In Millimeters		Dimensions In Inches	
	Min	Max	Min	Max
A	4.801	5.004	0.189	0.197
B	3.810	3.988	0.150	0.157
C	1.346	1.753	0.053	0.069
D	0.330	0.508	0.013	0.020
F	1.194	1.346	0.047	0.053
H	0.170	0.254	0.007	0.010
I	0.050	0.254	0.002	0.010
J	5.791	6.200	0.228	0.244
M	0.400	1.270	0.016	0.050

8-Lead SOP Plastic Package

RICHPower MICROELECTRONICS CORP.

Headquarter
 Room 2102, 1077 ZuChongZhi Road, Zhang Jiang
 Hi-TechPark, Pudong New Area, Shanghai, China
 Tel: (8621)50277077 Fax: (8621)50276966

RICHPower MICROELECTRONICS CORP.

Taipei Office (Marketing)
 8F, No. 137, Lane 235, Paochiao Road, Hsintien City
 Taipei County, Taiwan, R.O.C.
 Tel: (8862)89191466 Fax: (8862)89191465
 Email: marketing@richpower.com

Information that is provided by Richpower Technology Corporation is believed to be accurate and reliable. Richpower reserves the right to make any change in circuit design, specification or other related things if necessary without notice at any time. No third party intellectual property infringement of the applications should be guaranteed by users when integrating Richpower products into any application. No legal responsibility for any said applications is assumed by Richpower.