

DSC6XXX

Family of Ultra-Small Package, Ultra-Low Power MEMS Oscillators

Summary

The DSC6XXX family of MEMS oscillators combines the industry leading low power consumption and ultra-small packages with exceptional frequency stability and jitter performance over temperature. The single-output DSC6XXX MEMS oscillators are excellent choices for use as clock references in small, battery-powered devices such as wearable and Internet of Things (IoT) devices in which small size, low power consumption and long-term reliability are paramount. They also meet the stringent mechanical durability and reliability requirements within Automotive Electronics Council standard Q100 (AEC-Q100), so they are well suited for under-hood applications as well.

Key Features

- Ultra-small footprint
 - 1.6 mm × 1.2 mm, 75% of the footprint of quartz oscillators
- Ultra-low power consumption
 - 1.3 mA, 50% less than traditional low-power quartz oscillators
- High stability over wide temperature range
 - ± 25 ppm over -40° to 85°C
- High Reliability
 - 5 \times better vibration tolerance, 500 \times better mechanical shock tolerance
 - AEC-Q100 capable
- Highly flexible
 - Multi-rate output
 - Online and field tools allow fast sampling and rapid prototyping
- Wide frequency range: 2 kHz to 100 MHz
- Wide supply range: 1.71 to 3.63V



Target Applications

- Low power/portable applications: IoT, embedded/smart devices
- Consumer: home healthcare, fitness devices, home automation
- Automotive: back view/surround view cameras, infotainment systems
- Industrial: building/factory automation, surveillance cameras

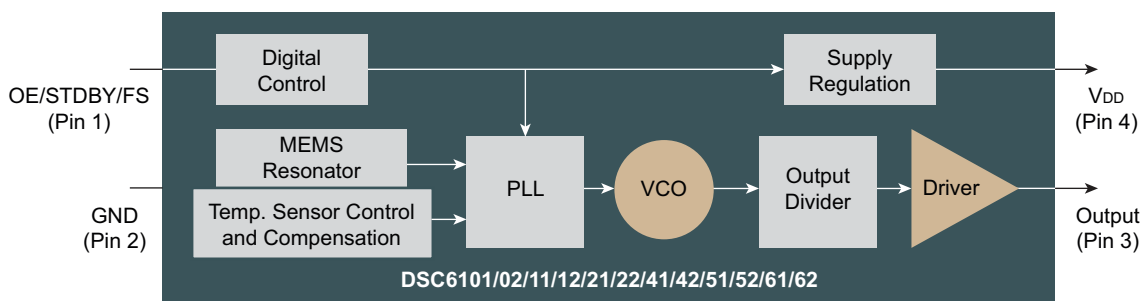

MICROCHIP

Development Tools

With these field- and web-based configuration tools, you can expect application-specific timing solutions with very short lead times regardless of the size of your project.

ClockWorks® Online Configurator



Configure DSC6XXX oscillators with this easy-to-use online tool to create full orderable part numbers and get fast samples. Watch the tutorial video at www.microchip.com/ClockWorksConfiguratorVideo.

For more information, please visit <http://clockworks.microchip.com/timing>.

TimeFlash Field Programming Kit



Instantly program the DSC6XXX oscillators to your frequency specifications using this field programming kit. Watch the video at www.microchip.com/TimeFlashFieldProgrammingKitVideo.

For more information, please visit: www.microchip.com/timeflash.

Product Family

Part Number	Description	Frequency Range	Power Consumption (typ.)	Period Jitter (RMS)	Package Size (mm)	Temperature Range	Stability (ppm)
DSC6101	Ultra-low power MEMS oscillator, lower jitter, Pin1 = OE, standard drive	1–100 MHz	3 mA	7.5 ps	H = 1.6 x 1.2 M = 2.0 x 1.6 J = 2.5 x 2.0 C = 3.2 x 2.5	E = -20 to 70°C I = -40 to 85°C	2 = ±25 1 = ±50
DSC6102	Ultra-low power MEMS oscillator, lower jitter, Pin1 = OE, high drive	1–100 MHz	3 mA	7.5 ps			
DSC6111	Ultra-low power MEMS oscillator, lower jitter, Pin1 = standby, standard drive	1–100 MHz	3 mA	7.5 ps			
DSC6112	Ultra-low power MEMS oscillator, lower jitter, Pin1 = standby, high drive	1–100 MHz	3 mA	7.5 ps			
DSC6121	Ultra-low power MEMS oscillator, lower jitter, Pin1 = frequency select, standard drive	1–100 MHz	3 mA	7.5 ps			
DSC6122	Ultra-low power MEMS oscillator, lower jitter, Pin1 = frequency select, high drive	1–100 MHz	3 mA	7.5 ps			
DSC6001	Ultra-low power MEMS oscillator, Pin1 = OE, standard drive	1–80 MHz	1.3 mA	20 ps			
DSC6003	Ultra-low power MEMS oscillator, Pin1 = OE, low drive	1–80 MHz	1.3 mA	25 ps			
DSC6011	Ultra-low power MEMS oscillator, Pin1 = standby, standard drive	1–80 MHz	1.3 mA	20 ps			
DSC6013	Ultra-low power MEMS oscillator, Pin1 = standby, low drive	1–80 MHz	1.3 mA	25 ps			
DSC6021	Ultra-low power MEMS oscillator, Pin1 = frequency select, standard drive	1–80 MHz	1.3 mA	20 ps			
DSC6023	Ultra-low power MEMS oscillator, Pin1 = frequency select, low drive	1–80 MHz	1.3 mA	25 ps			
DSC6183	Ultra-low power MEMS oscillator, lower jitter, output on pin 1	2–999 kHz	1.2 mA	15 ps			
DSC6083	Ultra-low power MEMS oscillator, output on pin 1	2–999 kHz	1.2 mA	25 ps			

To order samples and create an orderable part number, go to <http://clockworks.microchip.com/timing>.



MICROCHIP

www.microchip.com/DSC6000

Visit our web site for additional product information and to locate your local sales office.

Microchip Technology Inc. • 2355 W. Chandler Blvd. • Chandler, AZ 85224-6199

Microcontrollers • Digital Signal Controllers • Analog • Memory • Wireless