



MICROCHIP

**MCP8024 TQFP
BLDC Motor Driver
Evaluation Board
User's Guide**

Note the following details of the code protection feature on Microchip devices:

- Microchip products meet the specification contained in their particular Microchip Data Sheet.
- Microchip believes that its family of products is one of the most secure families of its kind on the market today, when used in the intended manner and under normal conditions.
- There are dishonest and possibly illegal methods used to breach the code protection feature. All of these methods, to our knowledge, require using the Microchip products in a manner outside the operating specifications contained in Microchip's Data Sheets. Most likely, the person doing so is engaged in theft of intellectual property.
- Microchip is willing to work with the customer who is concerned about the integrity of their code.
- Neither Microchip nor any other semiconductor manufacturer can guarantee the security of their code. Code protection does not mean that we are guaranteeing the product as "unbreakable."

Code protection is constantly evolving. We at Microchip are committed to continuously improving the code protection features of our products. Attempts to break Microchip's code protection feature may be a violation of the Digital Millennium Copyright Act. If such acts allow unauthorized access to your software or other copyrighted work, you may have a right to sue for relief under that Act.

Information contained in this publication regarding device applications and the like is provided only for your convenience and may be superseded by updates. It is your responsibility to ensure that your application meets with your specifications. MICROCHIP MAKES NO REPRESENTATIONS OR WARRANTIES OF ANY KIND WHETHER EXPRESS OR IMPLIED, WRITTEN OR ORAL, STATUTORY OR OTHERWISE, RELATED TO THE INFORMATION, INCLUDING BUT NOT LIMITED TO ITS CONDITION, QUALITY, PERFORMANCE, MERCHANTABILITY OR FITNESS FOR PURPOSE. Microchip disclaims all liability arising from this information and its use. Use of Microchip devices in life support and/or safety applications is entirely at the buyer's risk, and the buyer agrees to defend, indemnify and hold harmless Microchip from any and all damages, claims, suits, or expenses resulting from such use. No licenses are conveyed, implicitly or otherwise, under any Microchip intellectual property rights.

Trademarks

The Microchip name and logo, the Microchip logo, dsPIC, FlashFlex, KEELOQ, KEELOQ logo, MPLAB, PIC, PICmicro, PICSTART, PIC³² logo, rPIC, SST, SST Logo, SuperFlash and UNI/O are registered trademarks of Microchip Technology Incorporated in the U.S.A. and other countries.

FilterLab, Hampshire, HI-TECH C, Linear Active Thermistor, MTP, SEEVAL and The Embedded Control Solutions Company are registered trademarks of Microchip Technology Incorporated in the U.S.A.

Silicon Storage Technology is a registered trademark of Microchip Technology Inc. in other countries.

Analog-for-the-Digital Age, Application Maestro, BodyCom, chipKIT, chipKIT logo, CodeGuard, dsPICDEM, dsPICDEM.net, dsPICworks, dsSPEAK, ECAN, ECONOMONITOR, FanSense, HI-TIDE, In-Circuit Serial Programming, ICSP, Mindi, MiWi, MPASM, MPF, MPLAB Certified logo, MPLIB, MPLINK, mTouch, Omniscient Code Generation, PICC, PICC-18, PICDEM, PICDEM.net, PICkit, PICtail, REAL ICE, rLAB, Select Mode, SQI, Serial Quad I/O, Total Endurance, TSHARC, UniWinDriver, WiperLock, ZENA and Z-Scale are trademarks of Microchip Technology Incorporated in the U.S.A. and other countries.

SQTP is a service mark of Microchip Technology Incorporated in the U.S.A.

GestIC and ULPP are registered trademarks of Microchip Technology Germany II GmbH & Co. KG, a subsidiary of Microchip Technology Inc., in other countries.

All other trademarks mentioned herein are property of their respective companies.

© 2013, Microchip Technology Incorporated, Printed in the U.S.A., All Rights Reserved.

 Printed on recycled paper.

ISBN: 9781620777800

QUALITY MANAGEMENT SYSTEM
CERTIFIED BY DNV
== ISO/TS 16949 ==

Microchip received ISO/TS-16949:2009 certification for its worldwide headquarters, design and wafer fabrication facilities in Chandler and Tempe, Arizona; Gresham, Oregon and design centers in California and India. The Company's quality system processes and procedures are for its PIC[®] MCUs and dsPIC[®] DSCs, KEELOQ[®] code hopping devices, Serial EEPROMs, microperipherals, nonvolatile memory and analog products. In addition, Microchip's quality system for the design and manufacture of development systems is ISO 9001:2000 certified.



MCP8024 TQFP BLDC MOTOR DRIVER EVALUATION BOARD USER'S GUIDE

Table of Contents

Preface	7
Introduction.....	7
Document Layout	7
Conventions Used in this Guide	8
Recommended Reading.....	9
The Microchip Web Site	9
Development Systems Customer Change Notification Service	10
Customer Support	10
Document Revision History	10
Chapter 1. Product Overview	
1.1 Introduction	11
1.2 What is the MCP8024 TQFP BLDC Motor Driver Evaluation Board?	12
1.3 What the MCP8024 TQFP BLDC Motor Driver Evaluation Board Kit Includes	12
Chapter 2. Installation and Operation	
2.1 Introduction	13
2.2 Features	13
2.3 Getting Started	14
2.3.1 Connections	14
2.3.2 Operating a Motor	17
2.3.3 Indicator LEDs	18
2.3.4 Test Points	18
2.3.5 User Program Data Logging and Communications	19
2.3.6 Re-Programming the dsPIC DSC PIM	19
2.3.7 Configuring the MCP8024	19
2.3.8 MCP8024 Status	21
Appendix A. Schematic and Layouts	
A.1 Introduction	23
A.2 Board – Schematic	24
A.3 Board – Top Silk Layer	25
A.4 Board – Top Metal Layer	26
A.5 Board – Mid1 Metal Layer	27
A.6 Board – Mid2 Metal Layer	28
A.7 Board – Bottom Metal Layer	29
Appendix B. Bill of Materials (BOM)	

Appendix C. Software

C.1 Selected Software Constants and Definitions	35
C.2 dsPIC33FJ32MC204 PIM Port Usage	36
C.3 MPLAB X IDE Compiler Startup	37
C.4 MPLAB X IDE and PICKit 3 Programmer Exercise	37
Worldwide Sales and Service	40

Object of Declaration: MCP8024 TQFP BLDC Motor Driver Evaluation Board

EU Declaration of Conformity

This declaration of conformity is issued by the manufacturer.

The development/evaluation tool is designed to be used for research and development in a laboratory environment. This development/evaluation tool is not a Finished Appliance, nor is it intended for incorporation into Finished Appliances that are made commercially available as single functional units to end users under EU EMC Directive 2004/108/EC and as supported by the European Commission's Guide for the EMC Directive 2004/108/EC (8th February 2010).

This development/evaluation tool complies with EU RoHS2 Directive 2011/65/EU.

For information regarding the exclusive, limited warranties applicable to Microchip products, please see Microchip's standard terms and conditions of sale, which are printed on our sales documentation and available at www.microchip.com.

Signed for and on behalf of Microchip Technology Inc. at Chandler, Arizona, USA

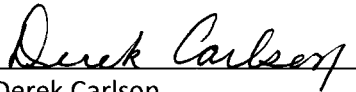

Derek Carlson

VP Development Tools

16-July-2013

Date

NOTES:



MCP8024 TQFP BLDC MOTOR DRIVER EVALUATION BOARD USER'S GUIDE

Preface

NOTICE TO CUSTOMERS

All documentation becomes dated, and this manual is no exception. Microchip tools and documentation are constantly evolving to meet customer needs, so some actual dialogs and/or tool descriptions may differ from those in this document. Please refer to our web site (www.microchip.com) to obtain the latest documentation available.

Documents are identified with a “DS” number. This number is located on the bottom of each page, in front of the page number. The numbering convention for the DS number is “DSXXXXA”, where “XXXX” is the document number and “A” is the revision level of the document.

For the most up-to-date information on development tools, see the MPLAB® IDE on-line help. Select the Help menu, and then Topics to open a list of available on-line help files.

INTRODUCTION

This chapter contains general information that will be useful to know before using the MCP8024 TQFP BLDC Motor Driver Evaluation Board. Items discussed in this chapter include:

- [Document Layout](#)
- [Conventions Used in this Guide](#)
- [Recommended Reading](#)
- [The Microchip Web Site](#)
- [Customer Support](#)
- [Document Revision History](#)

DOCUMENT LAYOUT

This document describes how to use the MCP8024 TQFP BLDC Motor Driver Evaluation Board. The manual layout is as follows:

- **Chapter 1. “Product Overview”** – Important information about the MCP8024 TQFP BLDC Motor Driver Evaluation Board.
- **Chapter 2. “Installation and Operation”** – Includes instructions on how to get started with this user’s guide and a description of the user’s guide.
- **Appendix A. “Schematic and Layouts”** – Shows the schematic and layout diagrams for the MCP8024 TQFP BLDC Motor Driver Evaluation Board.
- **Appendix B. “Bill of Materials (BOM)”** – Lists the parts used to build the MCP8024 TQFP BLDC Motor Driver Evaluation Board.
- **Appendix C. “Software”** – Provides information about the application firmware and where the source code can be found.

CONVENTIONS USED IN THIS GUIDE

This manual uses the following documentation conventions:

DOCUMENTATION CONVENTIONS

Description	Represents	Examples
Arial font:		
Italic characters	Referenced books	<i>MPLAB® IDE User's Guide</i>
	Emphasized text	...is the <i>only</i> compiler...
Initial caps	A window	the Output window
	A dialog	the Settings dialog
	A menu selection	select Enable Programmer
Quotes	A field name in a window or dialog	"Save project before build"
Underlined, italic text with right angle bracket	A menu path	<u><i>File>Save</i></u>
Bold characters	A dialog button	Click OK
	A tab	Click the Power tab
N'Rnnnn	A number in verilog format, where N is the total number of digits, R is the radix and n is a digit.	4'b0010, 2'hF1
Text in angle brackets < >	A key on the keyboard	Press <Enter>, <F1>
Courier New font:		
Plain Courier New	Sample source code	#define START
	Filenames	autoexec.bat
	File paths	c:\mcc18\h
	Keywords	_asm, _endasm, static
	Command-line options	-Opa+, -Opa-
	Bit values	0, 1
	Constants	0xFF, 'A'
Italic Courier New	A variable argument	<i>file.o</i> , where <i>file</i> can be any valid filename
Square brackets []	Optional arguments	mcc18 [options] <i>file</i> [options]
Curly brackets and pipe character: { }	Choice of mutually exclusive arguments; an OR selection	errorlevel {0 1}
Ellipses...	Replaces repeated text	var_name [, var_name...]
	Represents code supplied by user	void main (void) { ... }

RECOMMENDED READING

This user's guide describes how to use MCP8024 TQFP BLDC Motor Driver Evaluation Board. Other useful documents are listed below. The following Microchip documents are available and recommended as supplemental reference resources.

- **MCP8024 Data Sheet – “3-Phase Brushless DC (BLDC) Motor Gate Driver with Power Module” (DS20005228)**

This data sheet provides detailed information regarding the MCP8024 product family.

- **dsPIC33FJ32MC204 Data Sheet – “16-bit Digital Signal Controllers (up to 32 KB Flash and 2 KB SRAM) with Motor Control and Advanced Analog” (DS70283)**

This data sheet provides detailed information regarding the dsPIC33FJ32MC204 product family.

- **dsPIC33FJ32MC204 Plug-In-Module – “dsPIC33FJ32MC204 PIM Information Sheet” (DS70316)**

This data sheet provides detailed information regarding the dsPIC33FJ32MC204 PIM.

- **AN1078 Application Note – “Sensorless Field Oriented Control Of a PMSM” (DS01078).**
- **AN1160 Application Note – “Sensorless BLDC Control with Back-EMF Filtering Using a Majority Function” (DS01160).**
- **AN901 Application Note – “Using the dsPIC30F for Sensorless BLDC Control” (DS00901).**

THE MICROCHIP WEB SITE

Microchip provides online support via our web site at www.microchip.com. This web site is used as a means to make files and information easily available to customers. Accessible by using your favorite Internet browser, the web site contains the following information:

- **Product Support** – Data sheets and errata, application notes and sample programs, design resources, user's guides and hardware support documents, latest software releases and archived software
- **General Technical Support** – Frequently Asked Questions (FAQs), technical support requests, online discussion groups, Microchip consultant program member listing
- **Business of Microchip** – Product selector and ordering guides, latest Microchip press releases, listing of seminars and events, listings of Microchip sales offices, distributors and factory representatives

DEVELOPMENT SYSTEMS CUSTOMER CHANGE NOTIFICATION SERVICE

Microchip's customer notification service helps keep customers current on Microchip products. Subscribers will receive e-mail notification whenever there are changes, updates, revisions or errata related to a specified product family or development tool of interest.

To register, access the Microchip web site at www.microchip.com, click on Customer Change Notification and follow the registration instructions.

The Development Systems product group categories are:

- **Compilers** – The latest information on Microchip C compilers, assemblers, linkers and other language tools. These include all MPLAB C compilers; all MPLAB assemblers (including MPASM™ assembler); all MPLAB linkers (including MPLINK™ object linker); and all MPLAB librarians (including MPLIB™ object librarian).
- **Emulators** – The latest information on Microchip in-circuit emulators. This includes the MPLAB REAL ICE™ and MPLAB ICE 2000 in-circuit emulators.
- **In-Circuit Debuggers** – The latest information on the Microchip in-circuit debuggers. This includes MPLAB ICD 3 in-circuit debuggers and PICKit™ 3 debug express.
- **MPLAB® IDE** – The latest information on Microchip MPLAB IDE, the Windows® Integrated Development Environment for development systems tools. This list is focused on the MPLAB IDE, MPLAB IDE Project Manager, MPLAB Editor and MPLAB SIM simulator, as well as general editing and debugging features.
- **Programmers** – The latest information on Microchip programmers. These include production programmers such as MPLAB REAL ICE in-circuit emulator, MPLAB ICD 3 in-circuit debugger and MPLAB PM3 device programmers. Also included are non-production development programmers such as PICSTART® Plus and PICKit 2 and 3.

CUSTOMER SUPPORT

Users of Microchip products can receive assistance through several channels:

- Distributor or Representative
- Local Sales Office
- Field Application Engineer (FAE)
- Technical Support

Customers should contact their distributor, representative or field application engineer (FAE) for support. Local sales offices are also available to help customers. A listing of sales offices and locations is included in the back of this document.

Technical support is available through the web site at: <http://www.microchip.com/support>

DOCUMENT REVISION HISTORY

Revision A (December 2013)

- Initial Release of this Document.



MCP8024 TQFP BLDC MOTOR DRIVER EVALUATION BOARD USER'S GUIDE

Chapter 1. Product Overview

1.1 INTRODUCTION

The MCP8024 TQFP BLDC Motor Driver Evaluation Board is used to demonstrate the drive capabilities of the MCP8024. The board uses the MCP8024 3-Phase Brushless DC (BLDC) motor gate driver and dsPIC33FJ32MC204 Plug-In Module (PIM) to implement a 6-step trapezoidal BLDC motor controller.

The MCP8024 TQFP BLDC Motor Driver Evaluation Board is used to evaluate Microchip's MCP8024 in a BLDC motor application. As provided, the MCP8024 TQFP BLDC Motor Driver Evaluation Board is ready to operate a BLDC motor using one on-board push button to start and stop the motor, plus one on-board potentiometer to set motor speed. The evaluation board can drive a BLDC motor with a supply voltage of up to 28V and a motor current up to 15A. The MCP8024 TQFP BLDC Motor Driver Evaluation Board provides a 6-step trapezoidal control algorithm along with a 750 mW buck converter, 5V and 12V LDO, high-to-low level voltage translators, current sense operational amplifiers and Hall-effect inputs. The evaluation board provides a status indication for the power supplies and the six on-board Pulse-Width Modulation (PWM) inputs.

This chapter covers the following topics.

- [What is the MCP8024 TQFP BLDC Motor Driver Evaluation Board?](#)
- [What the MCP8024 TQFP BLDC Motor Driver Evaluation Board kit includes](#)

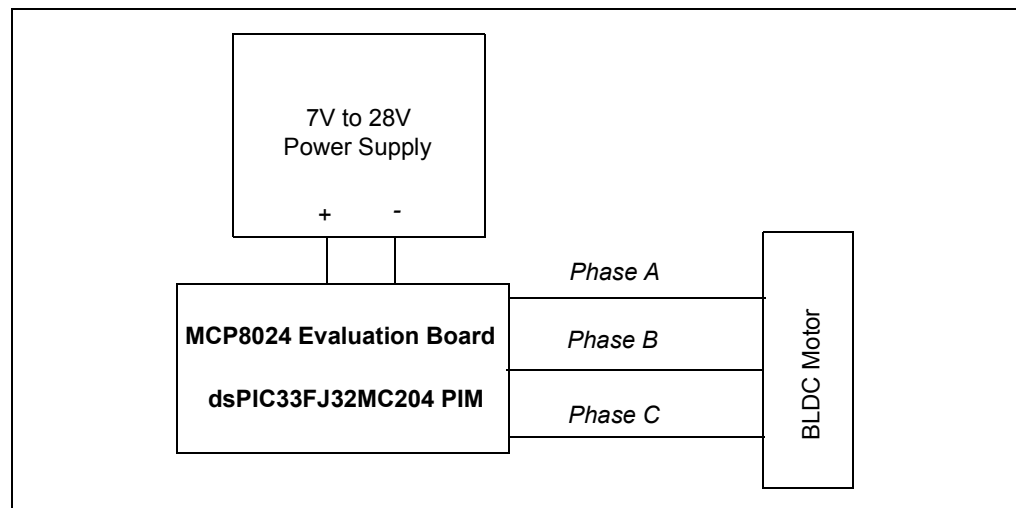

FIGURE 1-1: MCP8024 TQFP BLDC Motor Driver Evaluation Board Block Diagram.

1.2 WHAT IS THE MCP8024 TQFP BLDC MOTOR DRIVER EVALUATION BOARD?

The MCP8024 TQFP BLDC Motor Driver Evaluation Board is a complete stand-alone motor controller for brushless DC motors (BLDC). The board is capable of driving a three-phase brushless DC motor rated at up to 15A and 28V. The input voltage range for the board is 7V to 28V. The on-board MCP8024 generates 5V and 12V using internal voltage regulators. The MCP8024 also contains an internal buck regulator which generates the power for the attached dsPIC33FJ32MC204 host microcontroller.

An input terminal block is provided to apply the input voltage to the board. An output header and plated Printed Circuit Board (PCB) through-hole pads are also provided as a means to connect the external motor. Two programming headers are available for updating the firmware contained in the dsPIC33FJ32MC204 using either a PICKit™ 3 programmer/debugger, MPLAB® REAL ICE™ in-circuit emulator or an MPLAB ICD 3 In-circuit debugger.

Two headers are also supplied on the board to allow users to create SPI and I²C™ communication connections.

1.3 WHAT THE MCP8024 TQFP BLDC MOTOR DRIVER EVALUATION BOARD KIT INCLUDES

This MCP8024 TQFP BLDC Motor Driver Evaluation Board kit includes:

- MCP8024 TQFP BLDC Motor Driver Evaluation Board (ADM00557)
- dsPIC33FJ32MC204 Plug-In-Module (MA330017)
- Information Sheet



MCP8024 TQFP BLDC MOTOR DRIVER EVALUATION BOARD USER'S GUIDE

Chapter 2. Installation and Operation

2.1 INTRODUCTION

The MCP8024 TQFP BLDC Motor Driver Evaluation Board demonstrates Microchip's 3-Phase Brushless DC (BLDC) Motor Gate Driver with Power Module (MCP8024), used in a BLDC motor drive application. When used in conjunction with a microcontroller, the MCP8024 will provide the necessary drive signals to drive a 3-Phase BLDC motor. The MCP8024 contains the high-side and low-side drivers for external N-channel MOSFETs. The dsPIC33FJ32MC204 Motor Control processor is used to supply the PWM inputs to the MCP8024, as well as handle the high-speed Analog-to-Digital Conversion (ADC) required for 40 kHz PWM operation.

The MCP8024's UART interface is used to configure the device and to send fault information to the dsPIC[®] DSC controller. The evaluation board firmware, available on the Microchip website, uses a 6-step trapezoidal drive control algorithm to demonstrate the MCP8024 capabilities.

2.2 FEATURES

The MCP8024 TQFP BLDC Motor Driver Evaluation Board has the following features:

- Input Operating Voltage Range: +7.0V to +28V
- Maximum of 500 mA of gate drive current for external N-Channel MOSFETs
- Drives up to a 15A BLDC motor
- 750 mW Buck Regulator with resistor-programmable output voltage
- ON/OFF momentary contact switch
- Reset momentary contact switch
- Spare user-programmable momentary contact switch
- PWM signal LED indicators
- 100-pin dsPIC DSC PIM header for use with MA330017 compatible PIMs
- PICKit 3, MPLAB REAL ICE in-circuit emulator and MPLAB ICD 3 debugger interfaces
- Speed control potentiometer
- Terminal block for 5V and 12V Hall-effect sensors
- SPI and I²C headers for user communications
- Programmable external MOSFET overcurrent protection
- Programmable PWM dead-time protection
- Programmable PWM blanking time for current switching spikes
- Complete "C" source code (provided on the board web page)

2.3 GETTING STARTED

The MCP8024 TQFP BLDC Motor Driver Evaluation Board is fully assembled and tested for driving a BLDC motor. This board requires the use of an external voltage source capable of supplying 7V to 28V at the rated motor current. A BLDC motor is also required to evaluate the motor driver.

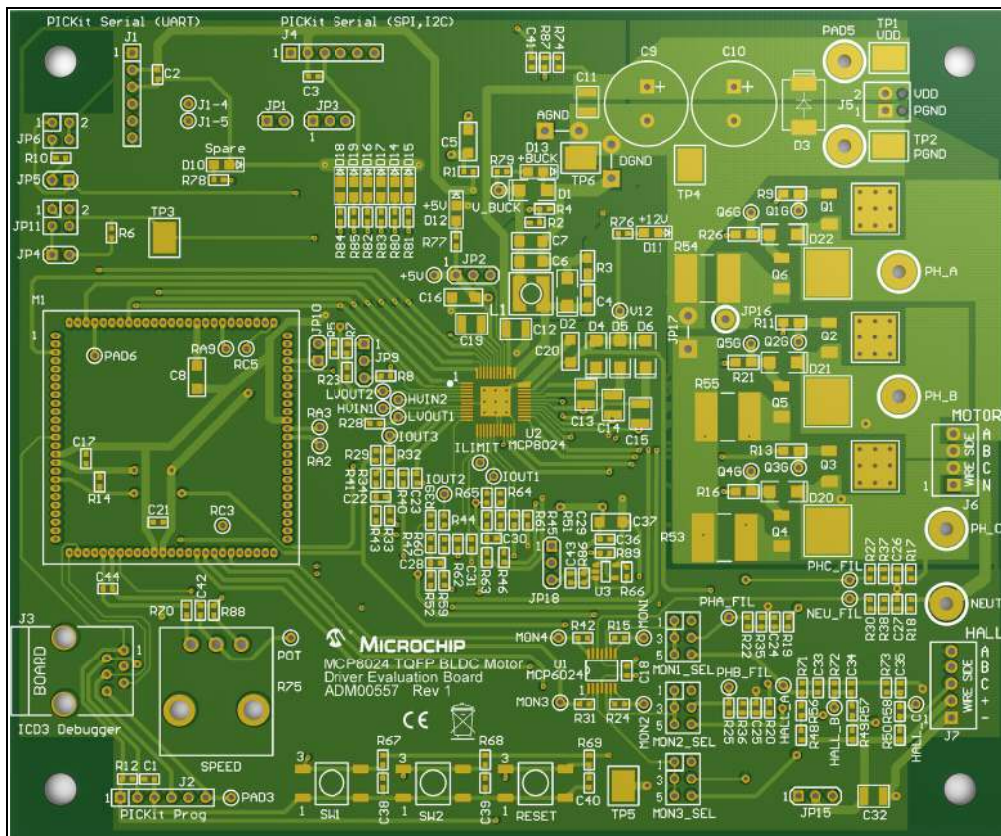

FIGURE 2-1: MCP8024 TQFP BLDC Motor Driver Evaluation Board Overlay.

2.3.1 Connections

2.3.1.1 JUMPER SETTINGS

The MCP8024 TQFP BLDC Motor Driver Evaluation Board has several user-configurable jumpers. The jumpers are described in [Table 2-1](#).

TABLE 2-1: MCP8024 TQFP BLDC MOTOR DRIVER EVALUATION BOARD JUMPERS

Jumper	Position	Description
JP1	ON	SPI Communications
JP2	1-2	Disable Buck Regulator
	2-3	Enable Buck Regulator
JP3	1-2	I ² C™ Communications
	2-3	SPI Communications
JP4	ON	Enable dsPIC® DSC to DE2 Communications
JP5	ON	Enable dsPIC DSC to DE2 Communications
JP6	1-2	Enable dsPIC DSC to PICKit™ Serial Communications
	3-4	Enable DE2 to PICKit Serial Communications

TABLE 2-1: MCP8024 TQFP BLDC MOTOR DRIVER EVALUATION BOARD JUMPERS (CONTINUED)

Jumper	Position	Description
JP9	1-2	CE Pull Up
	2-3	CE Pull Down
JP10	ON	Routes DE2 to dsPIC DSC RP20/CN25/RC4 pin
JP11	1-2	Enable DE2 to PICKit Serial Communications
	3-4	Enable dsPIC DSC to PICKit Serial Communications
JP12 (MONITOR1)	1-2	Connect Phase Current to MONITORn
JP13 (MONITOR2)	3-4	Connect Filtered Phase Voltage to MONITORn
JP14 (MONITOR3)	5-6	Connect Hall Sensor to MONITORn
JP15	1-2	5V Hall Sensor Power Supply
	2-3	12V Hall Sensor Power Supply
JP16	—	Sums Individual Phase Currents (soldered wire)
JP17	—	Select Individual Phase Currents (soldered wire)
JP18	1-2	Current Sense Offset = 0.992V
	2-3	Current Sense Offset = 0.0V

2.3.1.1.1 The jumpers and their use are described in [Table 2-2](#).

TABLE 2-2: JUMPER DESCRIPTION

Jumper	Position	Description
JP1 (used with JP3)	ON	Enables PICKit™ Serial SPI (J4) communications to the dsPIC® DSC
JP2	1-2	Disables the MCP8024 buck regulator by connecting the FB pin to +5V
	2-3	Enables the MCP8024 buck regulator by connecting the FB pin to the buck output voltage divider
JP3 (used with JP1)	1-2	Enables PICKit Serial I ² C™ (J4) communications to the dsPIC DSC
	2-3	Enables PICKit Serial SPI (J4) communications to the dsPIC DSC
JP4	ON	Enables the dsPIC DSC to Transmit to the MCP8024 DE2 pin
JP5	ON	Enables the dsPIC DSC to Receive from the MCP8024 DE2 pin
JP6	1-2	Enables PICKit Serial UART (J1) Transmissions to the dsPIC DSC
	3-4	Enables PICKit Serial UART (J1) Transmissions to the MCP8024 DE2 pin
JP7		Permanent jumper wire connecting Digital ground to Power ground
JP8		Permanent jumper wire connecting Analog ground to Power ground
JP9	1-2	Connects the MCP8024 CE pin to a pull-up resistor
	2-3	Connects the MCP8024 CE pin to a pull-down resistor
JP10	ON	Connects the dsPIC DSC RP20/CN25/RC4 pin to the MCP8024 DE2 pin
JP11	1-2	Enables PICKit Serial UART (J1) Reception from the MCP8024 DE2 pin
	3-4	Enables PICKit Serial UART (J1) Reception from the dsPIC DSC
JP12	1-2	Connects the Phase A amplified motor current to the dsPIC DSC Monitor 1 input
	3-4	Connects the Phase A filtered motor current to the dsPIC DSC Monitor 1 input
	5-6	Connects the Phase A Hall-effect sensor input to the dsPIC DSC Monitor 1 input
JP13	1-2	Connects the Phase B amplified motor current to the dsPIC DSC Monitor 2 input
	3-4	Connects the Phase B filtered motor current to the dsPIC DSC Monitor 2 input
	5-6	Connects the Phase B Hall-effect sensor input to the dsPIC DSC Monitor 2 input

MCP8024 TQFP BLDC Motor Driver Evaluation Board User's Guide

TABLE 2-2: JUMPER DESCRIPTION (CONTINUED)

Jumper	Position	Description
JP14	1-2	Connects the Phase C amplified motor current to the dsPIC DSC Monitor 3 input
	3-4	Connects the Phase C filtered motor current to the dsPIC DSC Monitor 3 input
	5-6	Connects the Phase C Hall-effect sensor input to the dsPIC DSC Monitor 3 input
JP15	1-2	Sets the Hall effect supply to +5V
	2-3	Sets the Hall effect supply to +12V
JP16 (used with JP17)		Jumper wire connecting Phase B and Phase C sense resistors to Phase A sense resistor for summing phase currents
JP17 (used with JP16)		Jumper wire connecting Phase B and Phase C sense resistors to ground for using individual phase currents
JP18	1-2	Sets the current sense amplifier offset voltage to 0.992 volts
	2-3	Sets the current sense amplifier offset voltage to 0.0 volts

The jumper settings for use with the sensorless trapezoidal drive firmware are described in [Table 2-3](#).

TABLE 2-3: JUMPERS USED BY SENSORLESS TRAPEZOIDAL FIRMWARE

Jumper	Position	Description
JP2	2-3	Enable Buck Regulator
JP4	ON	Enable dsPIC [®] DSC to DE2 Communications
JP5	ON	Enable dsPIC DSC to DE2 Communications
JP6	OFF	Disable dsPIC DSC to PICKIT [™] Serial Communications
	OFF	Disable DE2 to PICKIT Serial Communications
JP9	2-3	CE Pull Down
JP10	OFF	Disconnect DE2 to dsPIC DSC RP20/CN25/RC4 pin
JP11	OFF	Disable DE2 to PICKIT Serial Communications
	OFF	Disable dsPIC DSC to PICKIT Serial Communications
JP12 (MONITOR1) JP13 (MONITOR2) JP14 (MONITOR3)	3-4	Connect Filtered Phase Voltage to MONITORn
JP16	OFF	Deselect Summing Phase Currents
JP17	ON	Select Individual Phase Currents
JP18	1-2	Current Sense Offset by 0.992V

2.3.1.2 POWERING THE MCP8024 TQFP BLDC MOTOR DRIVER EVALUATION BOARD (REFERENCE [Figure 2-2](#))

1. Apply the input voltage to the input terminal block J5. The input voltage source should be limited to the 0V to +28V range. For nominal operation, the input voltage should be between +7.0V and +24V.
2. Connect the positive side of the input source (+) to pin 2 of J5. Connect the negative or return side (-) of the input source to pin 1 of J5. Refer to [Figure 2-2](#).

Installation and Operation

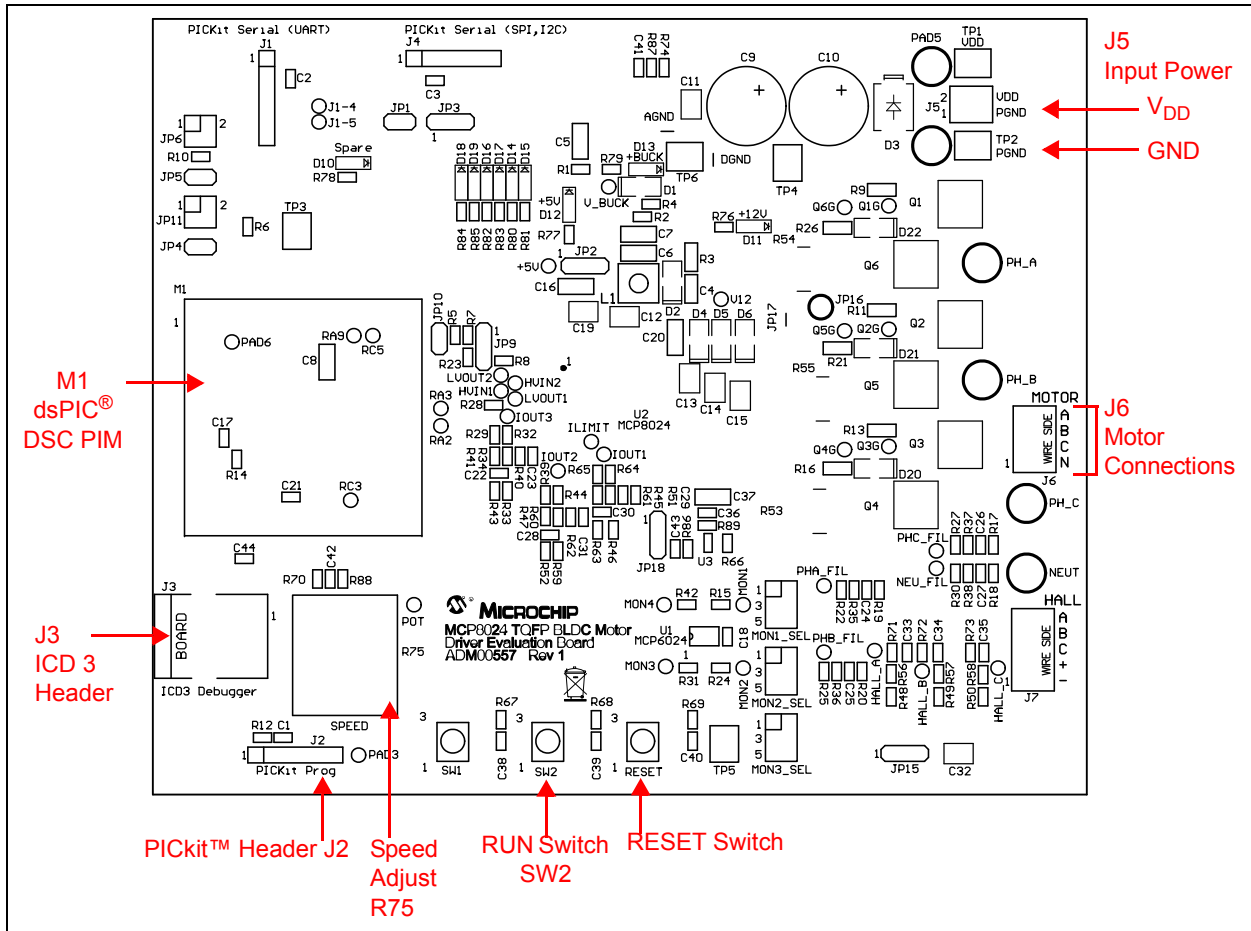

FIGURE 2-2: Connection and Operation Diagram.

2.3.1.3 CONNECTING A MOTOR MCP8024 TQFP BLDC MOTOR DRIVER EVALUATION BOARD

Connect each phase winding of the three-phase BLDC motor to the appropriate terminal of the motor terminal block (J6), terminals A,B,C. The neutral winding, terminal N, is not necessary for the sensorless trapezoidal drive firmware provided for the evaluation board.

2.3.2 Operating a Motor

1. Turn the Speed Adjust potentiometer (R75) fully counter-clockwise to obtain the slowest speed setting. Now turn the Speed Adjust approximately $\frac{1}{4}$ turn clockwise to allow for 25% motor speed.
2. Turn on the power supply connected to the board.
3. Press and release the RUN switch (SW2) to start the motor.
4. Turn the Speed Adjust potentiometer clockwise to increase motor speed, and counter-clockwise to decrease motor speed. The Speed Adjust changes the PWM duty cycle of the PWM signals that are being sent to the MCP8024.
5. Press and release the RUN switch again to stop the motor.

2.3.3 Indicator LEDs

The MCP8024 TQFP BLDC Motor Driver Evaluation Board has ten LEDs to indicate system status. [Table 2-4](#) lists the LED indicators and their descriptions.

TABLE 2-4: LED INDICATORS

PCB Location	Name	Description
D10	SPARE	Spare LED on RA4 port
D11	+12V	+12V LDO Voltage Operating
D12	+5V	+5V LDO Voltage Operating
D13	+Buck	Buck Output Voltage Operating
D14	PWM3H	PWM Phase 3 high-side input to MCP8024
D15	PWM3L	PWM Phase 3 low-side input to MCP8024
D16	PWM2H	PWM Phase 2 high-side input to MCP8024
D17	PWM2L	PWM Phase 2 low-side input to MCP8024
D18	PWM1H	PWM Phase 1 high-side input to MCP8024
D19	PWM1L	PWM Phase 1 low-side input to MCP8024

2.3.4 Test Points

There are several test points on the board to allow probing of voltages, currents and signals.

TABLE 2-5: TEST POINTS DESCRIPTION

Test Point	Name	Description
TP1	VDD	Power Supply (+)
TP2	PGND	Power Supply Ground (-)
TP3	DE2	MCP8024 DE2 Communications Signal
TP4	PGND	Power Supply Ground (-)
TP5	PGND	Power Supply Ground (-)
TP6	PGND	Power Supply Ground (-)
PHA_FIL	PHA_FIL	Filtered Phase A Signal
PHB_FIL	PHB_FIL	Filtered Phase B Signal
PHC_FIL	PHC_FIL	Filtered Phase C Signal
NEU_FIL	NEU_FIL	Filtered Neutral Signal
MON1	MON1	Monitor Signal 1: Connects to A/D Channel 3
MON2	MON2	Monitor Signal 2: Connects to A/D Channel 4
MON3	MON3	Monitor Signal 3: Connects to A/D Channel 5
MON4	MON4	Monitor Signal 4: Connects to A/D Channel 6
D14	PWM3H	PWM Phase C High-side Input to MCP8024
D15	PWM3L	PWM Phase C Low-side Input to MCP8024
D16	PWM2H	PWM Phase B High-side Input to MCP8024
D17	PWM2L	PWM Phase B Low-side Input to MCP8024
D18	PWM1H	PWM Phase A High-side Input to MCP8024
D19	PWM1L	PWM Phase A Low-side Input to MCP8024
PAD42	POT	Speed Adjust Potentiometer. Clockwise increases voltage (speed), counter-clockwise decreases voltage (speed).

2.3.5 User Program Data Logging and Communications

Headers J1 and J4 are provided for user-programmed serial communications using the PICKit Serial Analyzer. The user may add code to the firmware to allow communications between the PICKit Serial Analyzer and the dsPIC33FJ32MC204 processor. The communications mode may be UART, SPI or I²C.

2.3.6 Re-Programming the dsPIC DSC PIM

The dsPIC33FJ32MC204 PIM included with the evaluation kit may be re-programmed with the user's desired firmware. The PIM may be programmed on the evaluation board by using an external power source and either a PICKit 3 programmer, MPLAB REAL ICE in-circuit emulator or MPLAB ICD 3.

1. Connect the power source to the board as explained in [Section 2.3.1.2](#).
2. Connect a PICKit 3 to the J2 header or connect either an MPLAB ICD 3 or MPLAB REAL ICE in-circuit emulator to the J3 (RJ12) jack.
3. Open up the MPLAB X Integrated Development Environment (IDE) and load the MCP8024 TQFP BLDC Motor Driver Evaluation Board firmware project.

Note: Note that the following project options may need to be changed for the computer being used to build the firmware:

- Add Library `libdsp-elf.a` located in `XC16 ???\src\Libdsp\lib` directory.
- Add XC16-as ASM Include Directory in `XC16 ???\src\Libdsp\asm`.
- Set Hardware tool to "ICD 3", "MPLAB REAL ICE" or "PICKit3".

4. Build the project.
5. Program the device.
6. Press the RESET switch on the board to reset the processor and allow the processor to execute the new firmware program.

2.3.7 Configuring the MCP8024

The MCP8024 has configuration registers that may be used to modify operating parameters of the device. The parameters are modified by sending commands to the MCP8024 using the DE2 communication bus. The DE2 communication bus is a half-duplex, 9600 baud, 8-data bits, 1-stop bit, 1-start bit, no parity, serial communication link. The user may add code to the evaluation board firmware to communicate with the registers. The evaluation board software contains a subroutine which initializes the MCP8024 registers.

There are three configuration registers that may be written to. The registers are written to by sending a `SET_CFG_x` command byte followed by the desired register value byte. The configuration commands are listed in [Table 2-6](#).

MCP8024 TQFP BLDC Motor Driver Evaluation Board User's Guide

TABLE 2-6: CONFIGURATION REGISTERS

Command	Byte	Bit	Value	Description
SET_CFG_0	1	—	81H	Set Configuration Register 0
	2	7	0	Reserved
		6	0	Disable disconnect of 30K level translator pull up when CE = 0 (default)
			1	Enable disconnect of 30K level translator pull up when CE = 0
		5	0	Reserved
		4	0	Reserved
		3	0	Enable driver undervoltage lockout (default)
			1	Disable driver undervoltage lockout
		2	0	Enable external MOSFET short circuit detection (default)
			1	Disable external MOSFET short circuit detection
		1-0	00	Set external MOSFET overcurrent limit to 0.250V (default)
			01	Set external MOSFET overcurrent limit to 0.500V
			10	Set external MOSFET overcurrent limit to 0.750V
11	Set external MOSFET overcurrent limit to 1.000V			
SET_CFG_1	1	—	83H	Set Configuration Register 1
	2	7-0	00H – FFH	Select DAC current reference value $(4.503V - 0.991V)/255 = 13.77 \text{ mV/bit}$ 00H = 0.991V 40H = 1.872V = 40H * 13.77 mV/Bit + 0.991V (default) FFH = 4.503V = FFH * 13.77 mV/Bit + 0.991V
SET_CFG_2	1	—	87H	Set Configuration Register 2
	2	7-4	0000	Reserved
		3-2	—	Driver PWM dead time
			00	2 μ s (default)
			01	1 μ s
			10	500 ns
			11	250 ns
		1-0	—	Driver Blanking Time (for Ignoring commutation spikes)
			00	4 μ s (default)
			01	2 μ s
			10	1 μ s
			11	500 ns

2.3.8 MCP8024 Status

The host may also solicit MCP8024 status information by issuing a STATUS_0 or STATUS_1 command. The MCP8024 may send an unsolicited STATUS_0 or STATUS_1 command to the host in the event of a fault or warning. The status registers are listed in [Table 2-7](#).

TABLE 2-7: STATUS REGISTERS

Command	Byte	Bit	Value	Description
STATUS_0	1	—	85H	Get Status Register 0 Command from Host to MCP8024
STATUS_1	1	—	86H	Get Status Register 1 Command from Host to MCP8024
STATUS_0	1	—	45H	Status Register 0 Response to Host from MCP8024
			85H	Status Register 0 Command to Host from MCP8024 (unsolicited)
	2	7-0	00000000	Normal Operation
			00000001	Temperature Warning ($T_J > +125^{\circ}\text{C}$ (Default Warning Level))
			00000010	Over Temperature ($T_J > +160^{\circ}\text{C}$)
			00000100	Input Undervoltage ($V_{DD} < 5.5\text{V}$)
			00001000	Reserved
			00010000	Input Overvoltage ($V_{DD} > 32\text{V}$)
			00100000	Buck Regulator Overcurrent
			01000000	Buck Regulator Output Undervoltage Warning
10000000	Buck Regulator Output Undervoltage (< 80%, brown-out error)			
STATUS_1	1	—	46H	Status Register 1 Response to Host from MCP8024
			86H	Status Register 1 Command to Host from MCP8024 (unsolicited)
	2	7-0	00000000	Normal Operation
			00000001	5V LDO Overcurrent
			00000010	12V LDO Overcurrent
			00000100	External MOSFET Undervoltage Lockout (UVLO)
			00001000	External MOSFET Overcurrent Detection
			00010000	Brown-out Reset – Config Lost (Start-up default = 1)
			00100000	Reserved
			01000000	Reserved
10000000	Reserved			

NOTES:



MCP8024 TQFP BLDC MOTOR DRIVER EVALUATION BOARD USER'S GUIDE

Appendix A. Schematic and Layouts

A.1 INTRODUCTION

This appendix contains the following schematics and layouts for the MCP8024 TQFP BLDC Motor Driver Evaluation Board:

- [Board – Schematic](#)
- [Board – Top Silk Layer](#)
- [Board – Top Metal Layer](#)
- [Board – Mid1 Metal Layer](#)
- [Board – Mid2 Metal Layer](#)
- [Board – Bottom Metal Layer](#)

A.2 BOARD - SCHEMATIC

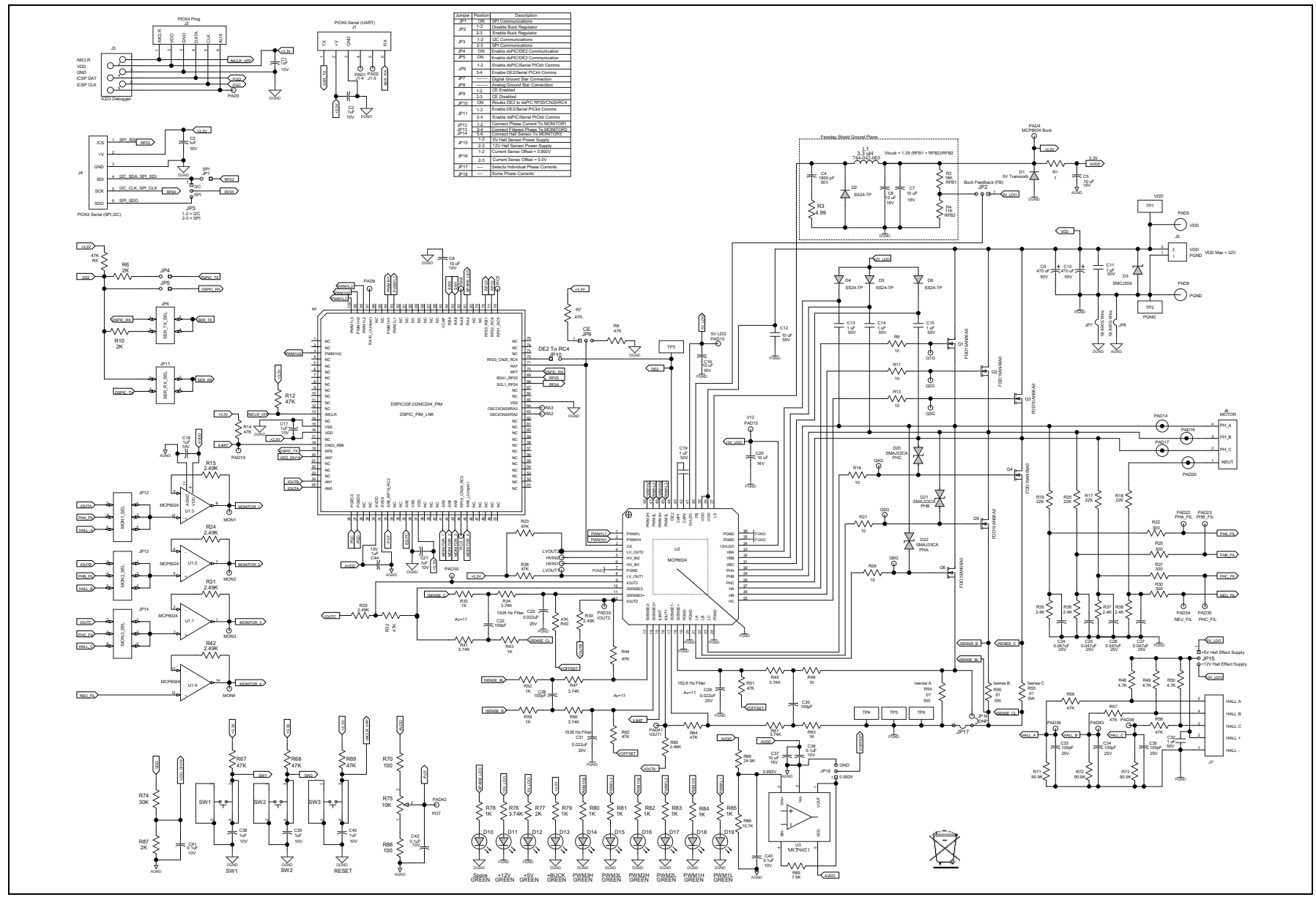

A.3 BOARD – TOP SILK LAYER

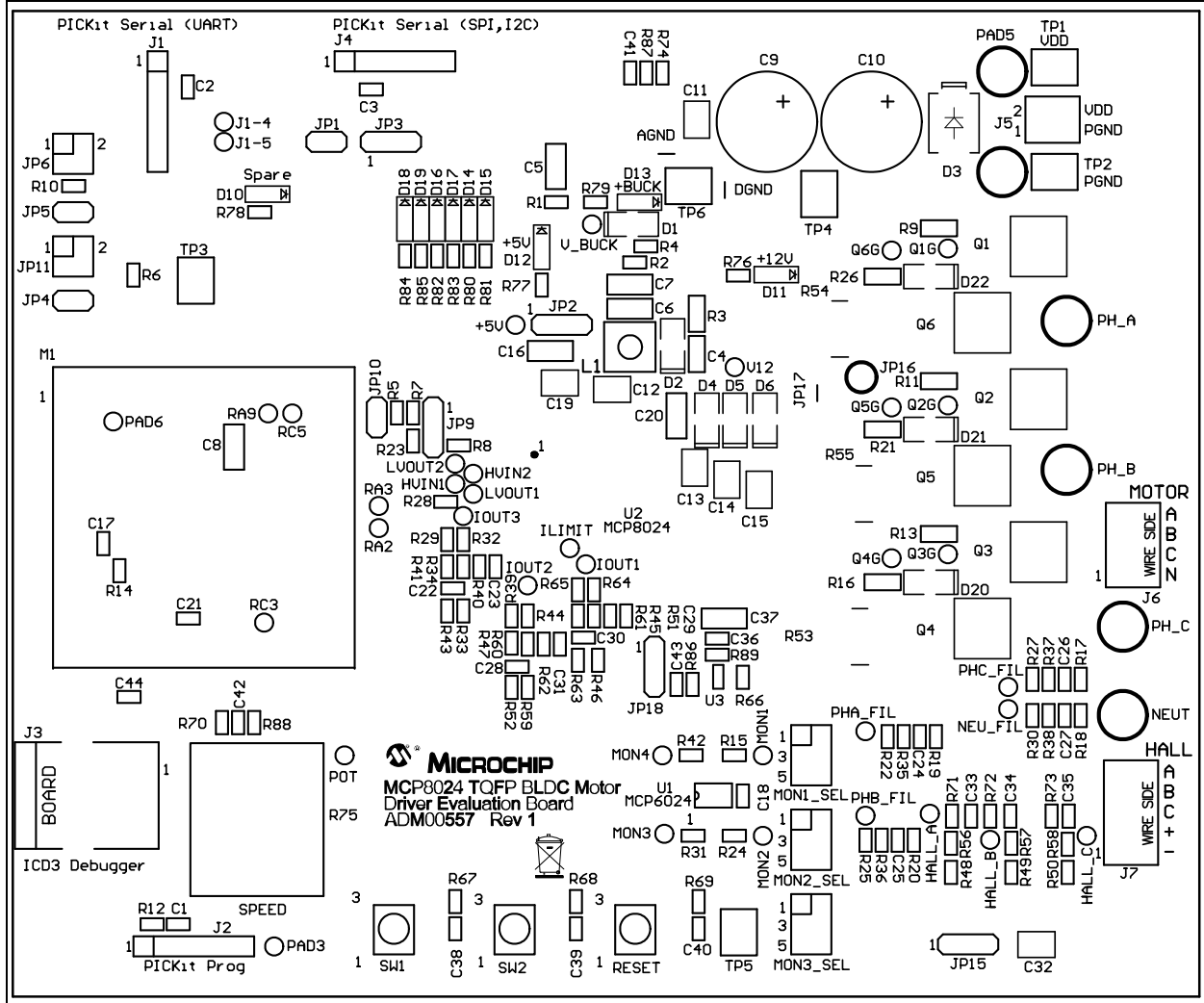

A.4 BOARD – TOP METAL LAYER

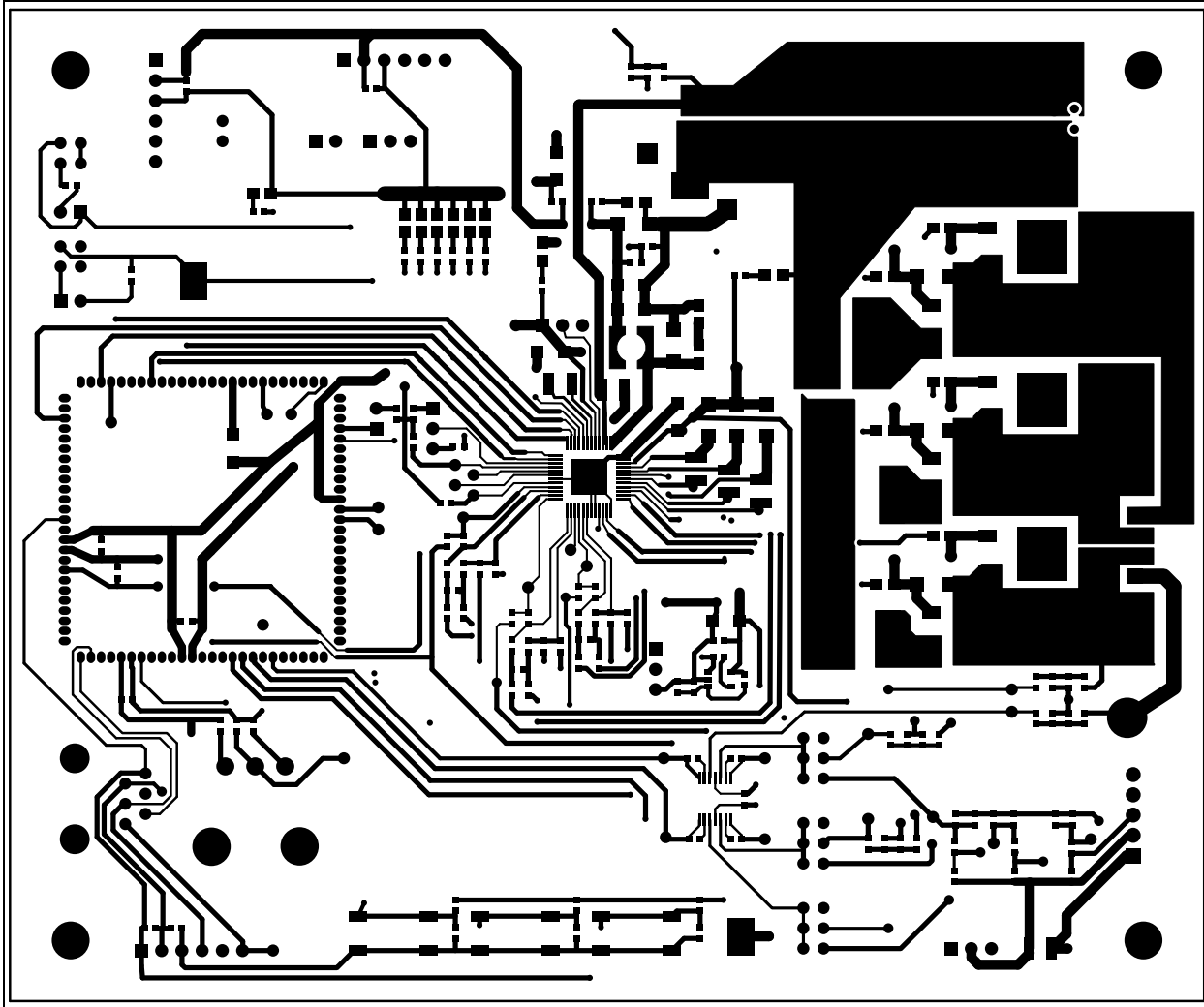

A.5 BOARD – MID1 METAL LAYER

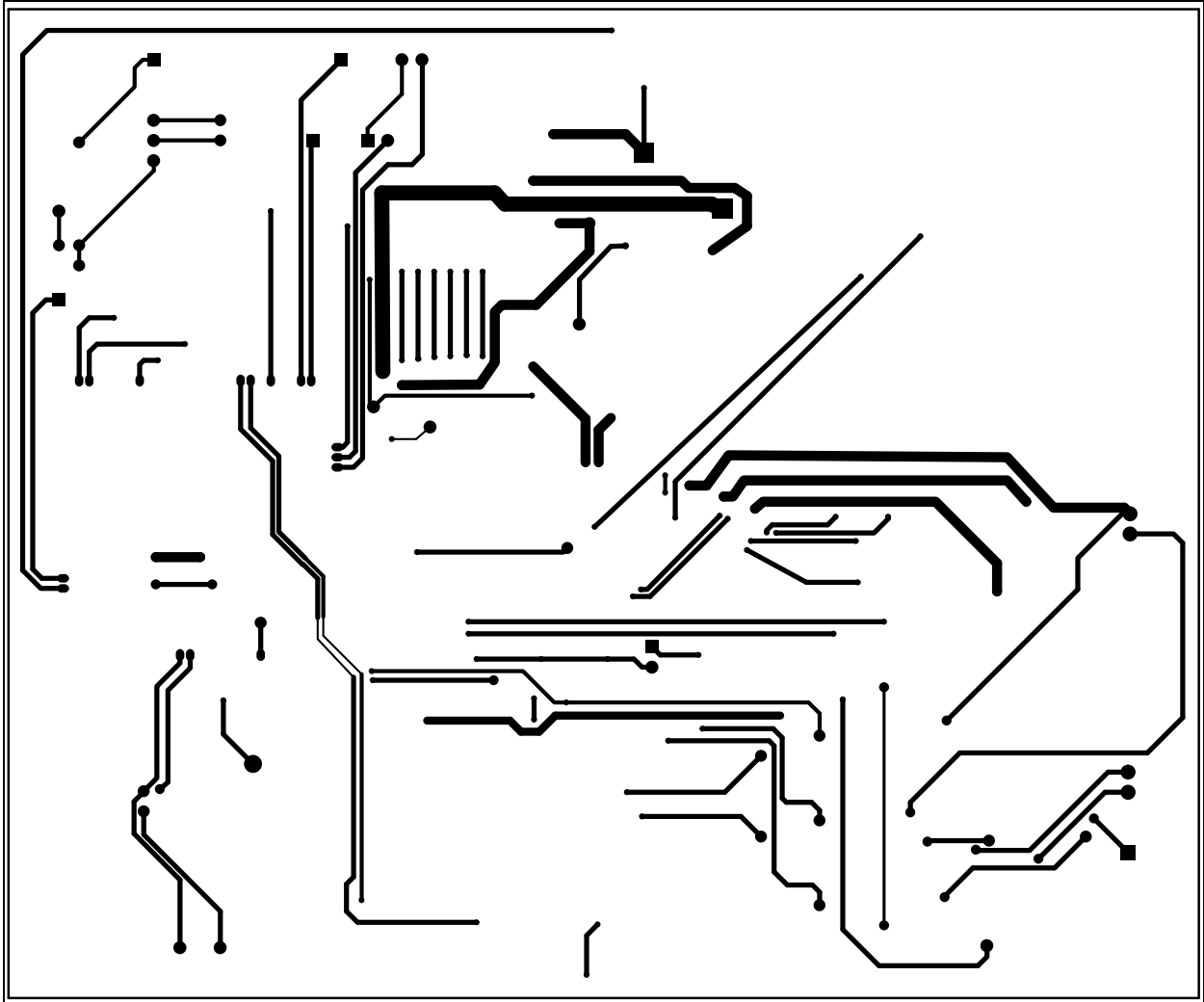

A.6 BOARD – MID2 METAL LAYER

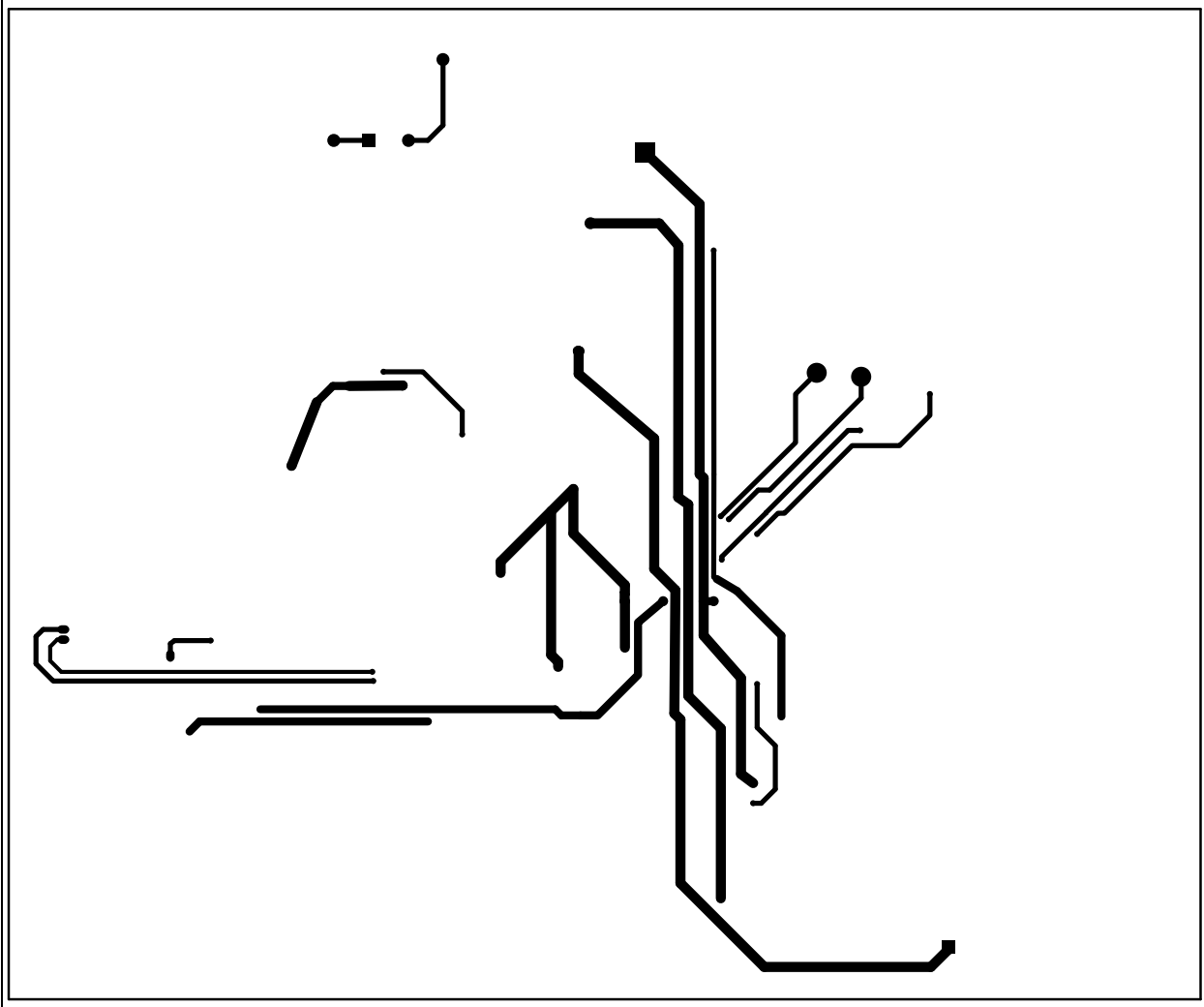

A.7 BOARD – BOTTOM METAL LAYER

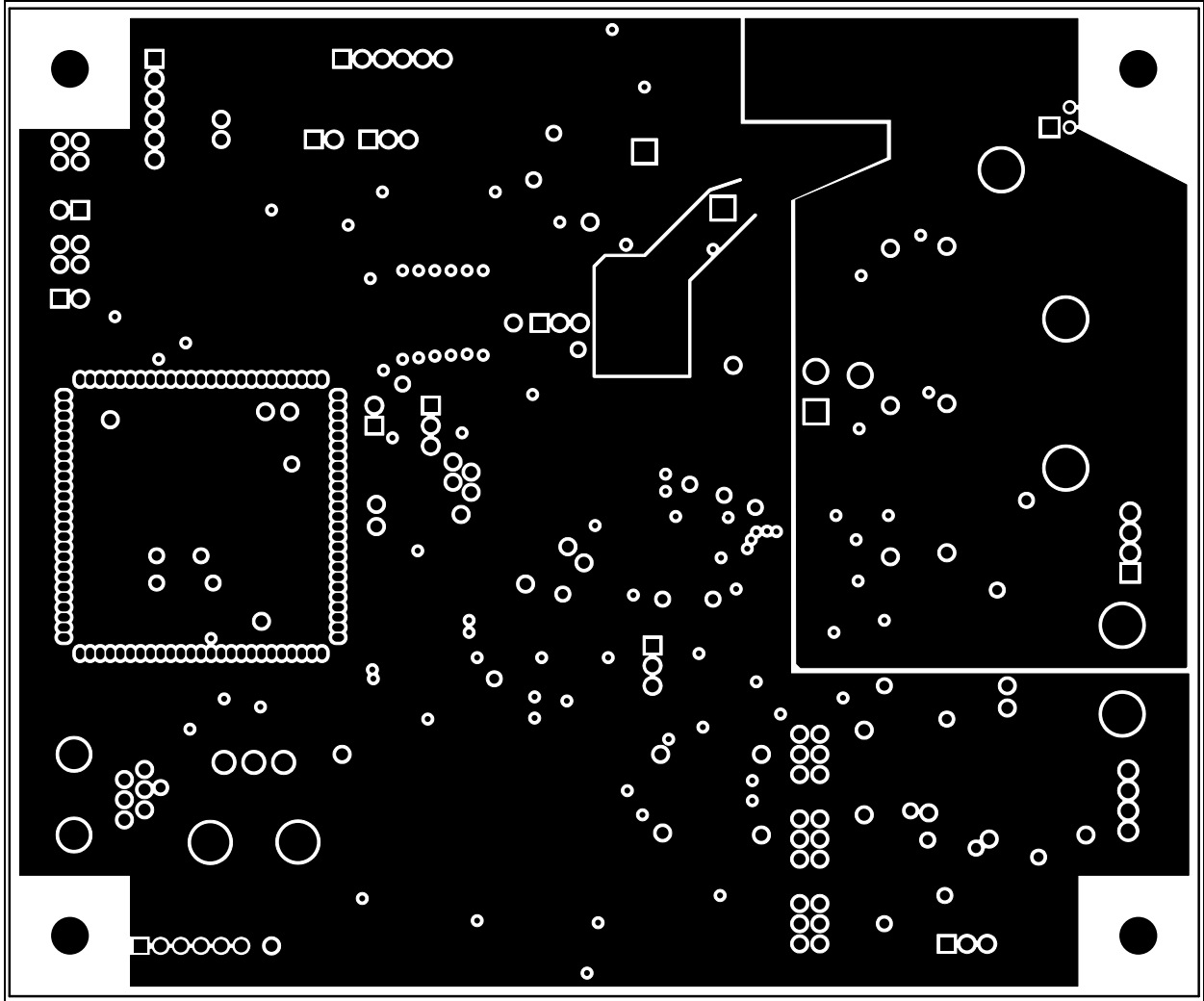

NOTES:



MCP8024 TQFP BLDC MOTOR DRIVER EVALUATION BOARD USER'S GUIDE

Appendix B. Bill of Materials (BOM)

TABLE B-1: BILL OF MATERIALS (BOM)

Qty	Designator	Description	Manufacturer	Part Number
4	Bumpsons	BUMPON TALL TAPER SQ .50X.23 BK	3M	SJ-5518(BLACK)
10	C1, C2, C3, C17, C18, C21, C38, C39, C40, C44	Cap Ceramic 1 µF 10V 10% X7R 0603	Taiyo Yuden Co., Ltd.	LMK107B7105KA-T
1	C4	Cap Ceramic 1800 pF 50V 10% X7R 0805	AVX Corporation	08055C182KAT2A
7	C5, C6, C7, C8, C16, C20, C37	Cap Ceramic 10 µF 16V 10% X7R 1206	TDK Corporation	C3216X7R1C106K160 AC
2	C9, C10	Cap Alum-Elect 470 µF 50V 20% Radial 12.5 mm Dia, 5 mm lead spacing	United Chemi-Con	EKZE500ELL471MK20 S
6	C11, C13, C14, C15, C19, C32	Cap Ceramic 1 µF 50V 10% X7R 1210	Taiyo Yuden Co., Ltd.	UMK325B7105KH-T
1	C12	Cap Ceramic 10 µF 50V 10% X5R 1210	Taiyo Yuden Co., Ltd.	UMK325BJ106KM-T
6	C22, C28, C30, C33, C34, C35	Cap Ceramic 100 pF 50V 10% X7R 0603	TDK Corporation	C1608X7R1H101K
			Vishay Intertechnology, Inc.	VJ0603Y101KX-ACW1BC
3	C23, C29, C31	Cap Ceramic 0.022 µF 25V 10% X7R 0603	TDK Corporation	C1608X7R1E223K
4	C24, C25, C26, C27	Cap Ceramic 0.047µF 25V 10% X7R 0603	Yageo Corporation	CC0603KRX7R8BB473
4	C36, C41, C42, C43	Cap Ceramic 0.1 µF 25V 10% X7R 0603	Yageo Corporation	CC0603KRX7R8BB104
1	D1	Transient Voltage Suppressor 400W 5% 5V SMA	Vishay Intertechnology, Inc.	SMAJ5.0A-E3/61
4	D2, D4, D5, D6	Diode Schottky 40V 2A SMA	Micro Commercial Components Corporation/Diodes® Incorporated	SS24-TP / B240A-13-F
1	D3	Transient Voltage Suppressor 1500W 30V SMC	Vishay Intertechnology, Inc.	SMCJ30A-E3/57T
10	D10, D11, D12, D13, D14, D15, D16, D17, D18, D19	Light Emitting Diode Green, 2 x 1.2 MM, 570 NM, WTR CLR, SMD	Kingbright	APT2012CGCK
3	D20, D21, D22	Transient Voltage Suppressor 400W 33V Bidirectional SMA	Vishay Intertechnology, Inc.	SMAJ33CA-E3/5A
3	J1, J2, J4	Header 1 x 6, 0.1 Centers	Molex®	0022284360 (1 rows x 36 columns, cut as needed)
1	J3	RJ12 6P6C Right Angle Jack	TE Connectivity, Ltd.	5555165-1
1	J5	Terminal Block 2 pin, 2.54mm	Phoenix Contact GmbH & Co.	Phoenix Contact 1725656

Note 1: The components listed in this Bill of Materials are representative of the PCB assembly. The released BOM used in manufacturing uses all RoHS-compliant components.

MCP8024 TQFP BLDC Motor Driver Evaluation Board User's Guide

TABLE B-1: BILL OF MATERIALS (BOM) (CONTINUED)

Qty	Designator	Description	Manufacturer	Part Number
1	J6	Terminal Block 4 pin, 2.54mm	Phoenix Contact GmbH & Co.	Phoenix Contact 1725672
1	J7	Terminal Block 5 pin, 2.54mm	Phoenix Contact GmbH & Co.	Phoenix Contact 1725686
14	JP**	CONN JUMPER SHORTING GOLD FLASH	Sullins Connector Solutions	SPC02SYAN
4	JP1, JP4, JP5, JP10	Header 1 x 2, 0.1 Centers	Molex	0022284360 (1 rows x 36 columns, cut as needed)
5	JP2, JP3, JP9, JP15, JP18	Header 1 x 3, 0.1 Centers	Molex	0022284360 (1 rows x 36 columns, cut as needed)
2	JP6, JP11	Header 2 x 2, 0.1 Centers	Molex	0702800448 (2 rows x 50 columns, cut as needed)
3	JP7, JP8, JP17	Wire 18 AWG, As needed	—	18 AWG bare wire as needed
3	JP12, JP13, JP14	Header 2 x 3, 0.1 Centers	Molex	0702800448 (2 rows x 50 columns, cut as needed)
1	L1	Inductor 3.3 μ H	Würth® Group	744-042-003
1	M1	dsPIC33F GP 44P QFN TO 100P PIM dsPIC33FJ32MC204	Microchip Technology Inc.	MA330017
4	M1 Headers	Fine Pitch Header, 1 row 25 columns	Samtec, Inc.	MTMS-125-01-G-S-230
6	Q1, Q2, Q3, Q4, Q5, Q6	MOSFET N-CH 60V 50A D-PAK	Fairchild Semiconductor®	FDD10AN06A0
1	PCB	Printed Circuit Board – MCP8024 TQFP BLDC Motor Driver Evaluation Board	Microchip Technology Inc.	104-10239
1	R1	RES 1.00 Ω 1/10W 1% 0603 SMD	Yageo Corporation	RC0603FR-071RL
1	R2	RES 18.0 k Ω 1/10W 1% 0603 SMD	Yageo Corporation	RC0603FR-0718KL
1	R3	RES 4.99 Ω 1/8W 1% 0805 SMD	Yageo Corporation	RC0805FR-074R99L
1	R4	RES 11.0 k Ω 1/10W 1% 0603 SMD	Yageo Corporation/ Panasonic® - ECG	RC0603FR-0711KL/ ERJ-3EKF1102V
19	R5, R7, R8, R12, R14, R23, R28, R32, R40, R44, R51, R56, R57, R58, R62, R64, R67, R68, R69	RES 47.0 k Ω 1/10W 1% 0603 SMD	Yageo Corporation	RC0603FR-0747KL
3	R6, R10, R87	RES 2.00 k Ω 1/10W 1% 0603 SMD	Yageo Corporation	RC0603FR-072KL
6	R9, R11, R13, R16, R21, R26	RES 10.0 Ω 1/8W 1% 0805 SMD	Yageo Corporation	RC0805FR-0710RL
7	R15, R24, R29, R31, R39, R42, R65	RES 2.49 k Ω 1/10W 1% 0603 SMD	Yageo Corporation	RC0603FR-072K49L
4	R17, R18, R19, R20	RES 22.0 k Ω 1/10W 1% 0603 SMD	Yageo Corporation	RC0603FR-0722KL
4	R22, R25, R27, R30	RES 300 Ω 1/10W 1% 0603 SMD	Yageo Corporation	RC0603FR-07300RL

Note 1: The components listed in this Bill of Materials are representative of the PCB assembly. The released BOM used in manufacturing uses all RoHS-compliant components.

Bill of Materials (BOM)

TABLE B-1: BILL OF MATERIALS (BOM) (CONTINUED)

Qty	Designator	Description	Manufacturer	Part Number
14	R33, R43, R46, R52, R59, R63, R78, R79, R80, R81, R82, R83, R84, R85	RES 1.00 k Ω 1/10W 1% 0603 SMD	Yageo Corporation	RC0603FR-071KL
7	R34, R41, R45, R47, R60, R61, R76	RES 3.74 k Ω 1/10W 1% 0603 SMD	Yageo Corporation	RC0603FR-073K74L
4	R35, R36, R37, R38	RES 2.40 k Ω 1/10W 1% 0603 SMD	Yageo Corporation	RC0603FR-072K4L
3	R48, R49, R50	RES 4.70 k Ω 1/10W 1% 0603 SMD	Yageo Corporation	RC0603FR-074K7L
3	R53, R54, R55	RES .010 Ω 5W 1% FLAT SMD	TT Electronics Plc./IRC	OARSXPR010FLF
1	R66	RES 24.9 k Ω 1/10W 1% 0603 SMD	Yageo Corporation	RC0603FR-0724K9L
2	R70, R88	RES 100 Ω 1/10W 1% 0603 SMD	Yageo Corporation	RC0603FR-07100RL
3	R71, R72, R73	RES 90.9 k Ω 1/10W 1% 0603 SMD	Yageo Corporation	RC0603FR-0790K9L
1	R74	RES 30.0 k Ω 1/10W 1% 0603 SMD	Yageo Corporation	RC0603FR-0730KL
1	R75	Potentiometer 10 k Ω 1/8W CARB VERTICAL	CTS [®] Corporation	296UD103B1N
1	R77	RES 2.00 k Ω 1/10W 1% 0603 SMD	Yageo Corporation	RC0603FR-072KL
1	R86	RES 10.7 k Ω 1/10W 1% 0603 SMD	Yageo Corporation	RC0603FR-0710K7L
1	R89	RES 7.50 k Ω 1/10W 1% 0603 SMD	Yageo Corporation	RC0603FR-077K5L
3	SW1, SW2, SW3	SWITCH TACTILE SPST-NO 0.05A 12V	E-Switch [®] , Inc.	TL330INF260QG
6	TP1, TP2, TP3, TP4, TP5, TP6	SMT Test Point	Keystone Electronics Corp.	5016
1	U1	MCP6024 Quad Op Amp – Plastic TSSOP, 14-lead	Microchip Technology Inc.	MCP6024-E/ST
1	U2	3-Phase Brushless DC (BLDC) Motor Gate Driver with Power Module - Plastic Thin Quad Flatpack with Exposed Pad - 7x7 mm body, 48-lead, Thermally Enhanced (EP)	Microchip Technology Inc.	MCP8024-H/PT
1	U3	MCP6021 Single Op Amp - Plastic Small Outline Transistor (SOT-23), 5-lead	Microchip Technology Inc.	MCP6021T-E/OT

Note 1: The components listed in this Bill of Materials are representative of the PCB assembly. The released BOM used in manufacturing uses all RoHS-compliant components.

NOTES:



MCP8024 TQFP BLDC MOTOR DRIVER EVALUATION BOARD USER'S GUIDE

Appendix C. Software

C.1 SELECTED SOFTWARE CONSTANTS AND DEFINITIONS

1. **FOSC**
Microprocessor Oscillator Frequency in Hz. based upon PLL scaling.
2. **FPWM = 40000**
Selects dsPIC DSC PWM period in Hz.
3. **LOOPMODE = CLOSEDLOOPMODE**
Sets motor controller to use closed loop control. The PID control functions will be used to control motor speed.
4. **LOOPMODE = OPENLOOPMODE**
Sets motor controller to use open loop control. The speed adjust input relative position will be used to set the motor speed.
5. **PWM_MODE_SELECT = PWM_MODE_SELECT_INDEPENDENT**
Sets the low-side external MOSFET driver to operate independently of the high-side driver.
6. **PWM_MODE_SELECT = PWM_MODE_SELECT_COMPLEMENTARY**
Sets the low-side external MOSFET driver to operate in complement of the high-side driver.
7. **PWM_COUNTS_PER_PERIOD = (FCY/FPWM - 1)**
Defines the number of timer counts per PWM period.
8. **RAMP_UP_PERIODS**
Defines the number of PWM periods to use to ramp the motor speed during startup.
9. **MAX_DUTY_CYCLE**
Defines the maximum desired PWM duty cycle.
10. **MIN_DUTY_CYCLE**
Defines the minimum desired PWM duty cycle.
11. **MIN_SAMPLE_TIME**
Defines the minimum allowable PWM duty cycle based upon A/D sample time.
12. **STARTUP_DUTY_CYCLE**
Defines the minimum desired PWM duty cycle during motor startup.
13. **PHASE_ADVANCE_DEGREES**
Defines the number of electrical degrees (in timer tics) that will be subtracted from the calculated commutation timer reload count. This allows for compensating for any latencies in the system.
14. **ZC_BLANKING_COUNT**
Defines the number of PWM periods that the ADC readings are ignored. This allows filtering of signals after commutation when high voltage spikes may be present.
15. **unsigned int ReferenceSpeed**
Contains the motor target speed based upon the SPEED potentiometer input.

MCP8024 TQFP BLDC Motor Driver Evaluation Board User's Guide

16. [int DesiredSpeed](#)
Contains the desired motor target speed based upon the SPEED potentiometer input.
17. [int CurrentSpeed](#)
Contains the current motor speed.
18. [unsigned int SpeedControl_P](#)
Proportional term of the closed loop PID control function. Sets the motor gain coefficient for the current speed error.
19. [unsigned int SpeedControl_I](#)
Integral term of the closed loop PID control function. Sets the motor gain coefficient for previous speed changes.
20. [unsigned int SpeedControl_D](#)
Derivative term of the closed loop PID control function. Sets the motor gain coefficient for predicted errors in the motor control loop.
21. [PWM_STATE\[\]](#)
Array containing the high-side and low-side gate driver output states for a given step of the six-step commutation algorithm.
22. [BOOTSTRAP_CHARGE_STATE](#)
High-side and low-side gate driver output states for charging the bootstrap capacitors prior to motor startup.
23. [MOTOR_SHUTDOWN_STATE](#)
High-side and low-side gate driver output states that may be used when shutting down the motor.
24. [ADC_MASK\[\]](#)
A/D Back EMF mask used for majority detection.
25. [ADC_XOR\[\]](#)
A/D Back EMF mask used for majority detection.
26. [ADC_BEMF_FILTER\[\]](#)
A/D Back EMF filter table used to determine next commutation time.

C.2 DSPIC33FJ32MC204 PIM PORT USAGE

Port	Name	Description
/* Port A */		
PORTA.2	DEBUG_PORT1	General purpose debug port
PORTA.3	DEBUG_PORT2	General purpose debug port
PORTA.4	SPARE_LED	Spare LED port
PORTA.7	MCP8024_CE	1 = Enables MCP8024 output 0 = Disables MCP8024 output
PORTA.8	SW1	Spare push button input
/* Port B */		
PORTB.4	SW2	'On/Off' switch input
PORTB.8	ILIMIT_OUT	MCP8024 ILIMIT_OUT signal: 1 = OK 0 = Fault/Current Limit
/* Port C */		
PORTC.5	DEBUG_PORT3	General purpose debug port

C.3 MPLAB X IDE COMPILER STARTUP

1. Start the MPLAB X IDE compiler (not supplied, available on Microchip web page).
2. From the toolbar, select *File > Open Project*.
3. Browse to the evaluation board source code path.
4. Select the existing project file named `MCP8024_ADM00557_EVAL`.
5. In the Projects window, right mouse-click on `MCP8024_ADM00557_EVAL` and select Properties. The page contains the project properties. Processor, Compiler, Hardware and Config settings may be changed here.

Note: The user may need to modify the paths to the source files and linker files based upon their locations on the host computer. Make sure to verify that the Libraries contains the correct path to `libdsp-elf.a`.

6. Right click on the `MCP8024_ADM00557_EVAL` again and select the “Make and Program Device” option. This will compile the firmware and download to the programming hardware.
7. The compiler results will be displayed in the Output window frame. Verify success.

C.4 MPLAB X IDE AND PICKIT 3 PROGRAMMER EXERCISE

1. Start the MPLAB X (not supplied, available on Microchip web page).
2. From the toolbar, select *File > Open Project*.
3. Browse to the evaluation board source code path.
4. Select the existing workspace directory named `MCP8024_ADM00557_EVAL` or create a new one.
5. Connect the PICKIT 3 programmer to header J2 on the evaluation board. Align Pin 1 of the header with the Pin 1 mark on the programmer.
6. Set the bench power supply voltage control to the minimum voltage output.
7. Turn on the power supply and set the output voltage to 14V. Turn off the power supply.
8. Connect the bench power supply to the evaluation board. Connect +V(14V) to J5-2 and -V (Ground) to J5-1.
9. Turn on the power supply.
10. Right click on `MCP8024_ADM00557_EVAL` in the Projects window and select the “Make and Program Device” option. This will compile the firmware and program the dsPIC33FJ32MC204 PIM module.
11. The compiler results will be displayed in the Output window frame. Verify success.
12. Connect a brushless DC (BLDC) motor to connector J6. Connect the motor phase wires to the PH_A(J6-4), PH_B (J6-3) and PH_C (J6-2) terminals. The NEUT terminal (J6-1) is not used with the demonstration firmware.
13. Momentarily press the RESET switch on the evaluation board. This step is required to reset the dsPIC DSC device after programming.
14. Turn the SPEED adjustment fully counter-clockwise. This sets the motor to the slowest speed.
15. Momentarily press the SW2 switch to start the motor.
16. Momentarily press the SW2 switch again to stop the motor.
17. Momentarily press the SW2 switch again to start the motor.
18. Turn the SPEED adjustment clockwise. The motor speed should increase.

19. You may probe the different test points on the board to see the various signals being generated. The Q1G through Q6G test points will show the external MOSFET gate drive signals. The D14 through D19 LED's show the state of the PWM inputs to the MCP8024. The MON1 through MON4 test points show the output of the jumper-selected signals. PHA_FIL, PHB_FIL and PHC_FIL are the filtered back EMF voltages from the motor. They are used to determine the commutation time in the demonstration firmware.
20. Stop the motor by pressing SW2 again.
21. Change the motor control from Closed Loop to Open Loop. This is done by editing the `MCP8024_ADM00557_EVAL.C` file.
22. Click on Source Files in the Projects window and then double click on the `MCP8024_ADM00557_EVAL.C` entry.
23. Search for the pre-processor definition LOOPMODE.
24. Change the LOOPMODE definition from CLOSEDLOOPMODE to OPENLOOPMODE.
25. Right click on `MCP8024_ADM00557_EVAL` in the Projects window and select "Make and Program Device". This will compile the firmware and program the dsPIC33FJ32MC204 PIM module.
26. The compiler results will be displayed in the Output window frame. Verify success.
27. Momentarily press the RESET switch on the evaluation board. This step is required to reset the dsPIC DSC device after programming.
28. Turn the SPEED adjustment fully counter-clockwise. This sets the motor to the slowest speed.
29. Momentarily press the SW2 switch again to start the motor.
30. Turn the SPEED adjustment clockwise. The motor speed should increase.
31. In OPENLOOPMODE, the motor speed is forced based upon the position of the SPEED adjust potentiometer. If the SPEED adjust is set to 60%, the firmware will set the PWM duty cycle to 60%. While this allows for simple control of the motor, it is not efficient. If the motor is externally loaded, the motor may not be able to maintain the manually set commutation time which will result in a motor stall. The motor runs more efficiently when the motor is allowed to commute based upon rotor location and not by an external reference. In CLOSEDLOOPMODE, the motor will commute at the proper time based upon the Back EMF information. If the motor is externally loaded, the motor will automatically adjust for the load in order to maintain the correct commutation time.
32. Momentarily press the SW2 switch again to stop the motor.

NOTES:



MICROCHIP

Worldwide Sales and Service

AMERICAS

Corporate Office
2355 West Chandler Blvd.
Chandler, AZ 85224-6199
Tel: 480-792-7200
Fax: 480-792-7277
Technical Support:
<http://www.microchip.com/support>
Web Address:
www.microchip.com

Atlanta
Duluth, GA
Tel: 678-957-9614
Fax: 678-957-1455

Austin, TX
Tel: 512-257-3370

Boston
Westborough, MA
Tel: 774-760-0087
Fax: 774-760-0088

Chicago
Itasca, IL
Tel: 630-285-0071
Fax: 630-285-0075

Cleveland
Independence, OH
Tel: 216-447-0464
Fax: 216-447-0643

Dallas
Addison, TX
Tel: 972-818-7423
Fax: 972-818-2924

Detroit
Novi, MI
Tel: 248-848-4000

Houston, TX
Tel: 281-894-5983

Indianapolis
Noblesville, IN
Tel: 317-773-8323
Fax: 317-773-5453

Los Angeles
Mission Viejo, CA
Tel: 949-462-9523
Fax: 949-462-9608

New York, NY
Tel: 631-435-6000

San Jose, CA
Tel: 408-735-9110

Canada - Toronto
Tel: 905-673-0699
Fax: 905-673-6509

ASIA/PACIFIC

Asia Pacific Office
Suites 3707-14, 37th Floor
Tower 6, The Gateway
Harbour City, Kowloon
Hong Kong
Tel: 852-2401-1200
Fax: 852-2401-3431

Australia - Sydney
Tel: 61-2-9868-6733
Fax: 61-2-9868-6755

China - Beijing
Tel: 86-10-8569-7000
Fax: 86-10-8528-2104

China - Chengdu
Tel: 86-28-8665-5511
Fax: 86-28-8665-7889

China - Chongqing
Tel: 86-23-8980-9588
Fax: 86-23-8980-9500

China - Hangzhou
Tel: 86-571-2819-3187
Fax: 86-571-2819-3189

China - Hong Kong SAR
Tel: 852-2943-5100
Fax: 852-2401-3431

China - Nanjing
Tel: 86-25-8473-2460
Fax: 86-25-8473-2470

China - Qingdao
Tel: 86-532-8502-7355
Fax: 86-532-8502-7205

China - Shanghai
Tel: 86-21-5407-5533
Fax: 86-21-5407-5066

China - Shenyang
Tel: 86-24-2334-2829
Fax: 86-24-2334-2393

China - Shenzhen
Tel: 86-755-8864-2200
Fax: 86-755-8203-1760

China - Wuhan
Tel: 86-27-5980-5300
Fax: 86-27-5980-5118

China - Xian
Tel: 86-29-8833-7252
Fax: 86-29-8833-7256

China - Xiamen
Tel: 86-592-2388138
Fax: 86-592-2388130

China - Zhuhai
Tel: 86-756-3210040
Fax: 86-756-3210049

ASIA/PACIFIC

India - Bangalore
Tel: 91-80-3090-4444
Fax: 91-80-3090-4123

India - New Delhi
Tel: 91-11-4160-8631
Fax: 91-11-4160-8632

India - Pune
Tel: 91-20-3019-1500

Japan - Osaka
Tel: 81-6-6152-7160
Fax: 81-6-6152-9310

Japan - Tokyo
Tel: 81-3-6880-3770
Fax: 81-3-6880-3771

Korea - Daegu
Tel: 82-53-744-4301
Fax: 82-53-744-4302

Korea - Seoul
Tel: 82-2-554-7200
Fax: 82-2-558-5932 or
82-2-558-5934

Malaysia - Kuala Lumpur
Tel: 60-3-6201-9857
Fax: 60-3-6201-9859

Malaysia - Penang
Tel: 60-4-227-8870
Fax: 60-4-227-4068

Philippines - Manila
Tel: 63-2-634-9065
Fax: 63-2-634-9069

Singapore
Tel: 65-6334-8870
Fax: 65-6334-8850

Taiwan - Hsin Chu
Tel: 886-3-5778-366
Fax: 886-3-5770-955

Taiwan - Kaohsiung
Tel: 886-7-213-7830

Taiwan - Taipei
Tel: 886-2-2508-8600
Fax: 886-2-2508-0102

Thailand - Bangkok
Tel: 66-2-694-1351
Fax: 66-2-694-1350

EUROPE

Austria - Wels
Tel: 43-7242-2244-39
Fax: 43-7242-2244-393

Denmark - Copenhagen
Tel: 45-4450-2828
Fax: 45-4485-2829

France - Paris
Tel: 33-1-69-53-63-20
Fax: 33-1-69-30-90-79

Germany - Dusseldorf
Tel: 49-2129-3766400

Germany - Munich
Tel: 49-89-627-144-0
Fax: 49-89-627-144-44

Germany - Pforzheim
Tel: 49-7231-424750

Italy - Milan
Tel: 39-0331-742611
Fax: 39-0331-466781

Italy - Venice
Tel: 39-049-7625286

Netherlands - Drunen
Tel: 31-416-690399
Fax: 31-416-690340

Poland - Warsaw
Tel: 48-22-3325737

Spain - Madrid
Tel: 34-91-708-08-90
Fax: 34-91-708-08-91

Sweden - Stockholm
Tel: 46-8-5090-4654

UK - Wokingham
Tel: 44-118-921-5800
Fax: 44-118-921-5820

10/28/13