

FSAV450 — 800MHz, 4-Channel, 2:1 Video Switch

Features

- -50dB Off Isolation at 30MHz
- -80dB Non-Adjacent Channel Crosstalk at 30MHz
- 3dB Bandwidth: 800MHz
- On Resistance: 4Ω (Typical)
- Low Power Consumption: 1μA (Maximum)
- Control Input TTL Compatible

Applications

- RGB Video Switch in LCD, Plasma and Projector Displays

Description

The FSAV450 is a high performance Quad Single-Pole Double-Throw (SPDT) (2-to-1 multiplexer/ demultiplexer) video switch designed specifically for switching high definition YPbPr and computer RGB (up to UXGA) signals. The bandwidth of this device is 800MHz (typical) which allows signals to pass with minimal edge and phase distortion. Image integrity is maintained with low crosstalk, high off-Isolation and low differential gain and phase. The low on resistance (4Ω typical) minimizes signal insertion loss. Low voltage operation (3V), low power consumption (1μA maximum) and small scale packaging (including leadless DQFN) make this device ideal for a broad range of applications.

Ordering Information

Part Number	Operating Temperature Range	Package	Packing Method
FSAV450BQX	-40 to +85°C	16-Terminal Depopulated Quad Very-Thin Flat Pack No Leads (DQFN), JEDEC MO-241, 2.5 x 3.5mm	Tape and Reel

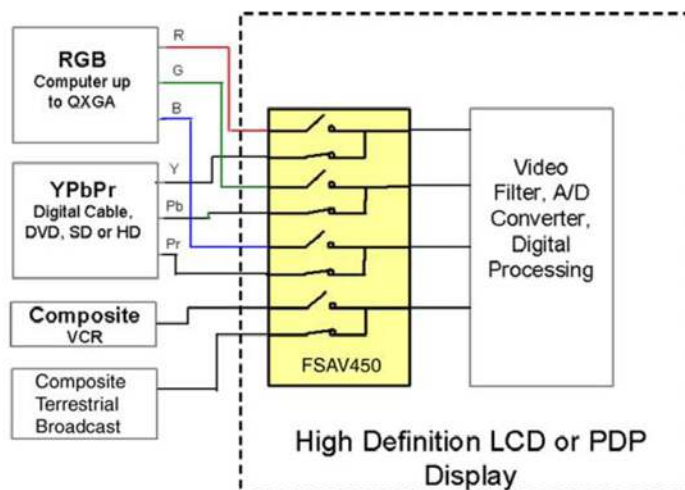

Figure 1. Typical Application Diagram

Pin Configurations

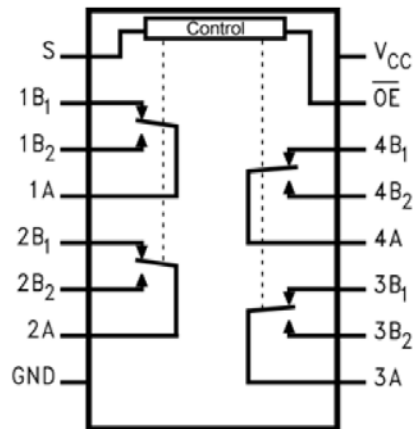

Figure 2. Analog Symbol

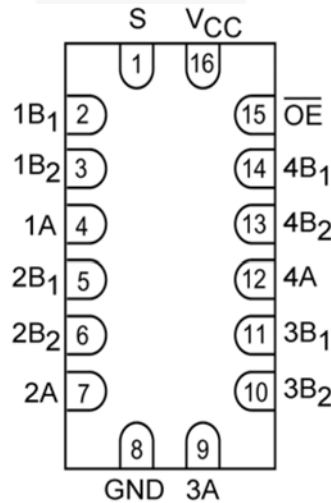

Figure 3. DQFN Pin Assignments

Pin Descriptions

Pin #	Name	Description
15	/OE	Bus Switch Enabled
1	S	Select Input
4, 7, 9, 12	A	Bus A
2, 3, 5, 6, 10, 11, 13, 14	B ₁ -B ₂	Bus B
8	GND	Ground
16	V _{CC}	Supply Voltage

Truth Table

S	/OE	Function
Don't Care	HIGH	Disconnected
LOW	LOW	A=B ₁
HIGH	LOW	A=B ₂

Absolute Maximum Ratings

Stresses exceeding the absolute maximum ratings may damage the device. The device may not function or be operable above the recommended operating conditions and stressing the parts to these levels is not recommended. In addition, extended exposure to stresses above the recommended operating conditions may affect device reliability. The absolute maximum ratings are stress ratings only.

Symbol	Parameter	Min.	Max.	Unit
V_{CC}	Supply Voltage	-0.5	+6.0	V
V_S	DC Switch Voltage	-0.5	+6.0	V
V_{IN}	DC Input Voltage ⁽¹⁾	-0.5	+6.0	V
I_{IK}	DC Input Diode Current, $V_{IN} < 0V$	-50		mA
I_{OUT}	DC Output Sink Current		128	mA
I_{CC}/I_{GND}	DC V_{CC} / GND Current		± 100	mA
T_{STG}	Storage Temperature Range	-65	+150	$^{\circ}C$
ESD	Human Body Model, JESD22-A114		2000	V

Note:

- The input and output negative voltage ratings may be exceeded if the input and output diode current ratings are observed.

Recommended Operating Conditions

The Recommended Operating Conditions table defines the conditions for actual device operation. Recommended operating conditions are specified to ensure optimal performance to the datasheet specifications. Fairchild does not recommend exceeding them or designing to Absolute Maximum Ratings.

Symbol	Parameter		Min.	Max.	Unit
V_{CC}	Power Supply		4.0	5.5	V
V_{IN}	Input Voltage		0	V_{CC}	V
V_{OUT}	Output Voltage		0	V_{CC}	V
t_r, t_f	Input Rise and Fall Time	Switch Control Input	0	5	ns/V
		Switch I/O	0	DC	
T_A	Operating Temperature, Free Air		-40	+85	$^{\circ}C$

Note:

- Unused control inputs must be held HIGH or LOW; they may not float.

DC Electrical Characteristics

Typical values are at $T_A = +25^\circ\text{C}$.

Symbol	Parameter	Conditions	V_{CC} (V)	$T_A = -40$ to $+85^\circ\text{C}$			Units
				Min.	Typ.	Max.	
V_{ANALOG}	Analog Signal Range			0		2	V
V_{IK}	Clamp Diode Voltage	$I_{IN} = -18\text{mA}$	4.5			-1.2	V
V_{IH}	High-Level Input Voltage		4.5 to 5.5	2.0			V
V_{IL}	Low-Level Input Voltage		4.5 to 5.5			0.8	V
I_I	Input Leakage Current	$0 \leq V_{IN} \leq 5.5\text{V}$	5.5			± 1.0	μA
I_{OFF}	Off-State Leakage Current	$0 \leq A, B \leq V_{CC}$	5.5			± 1.0	μA
R_{ON}	Switch On Resistance ⁽³⁾	$V_{IN} = 1.0\text{V}, R_I = 75\Omega, I_{ON} = 13\text{mA}$	4.5		4	6	Ω
		$V_{IN} = 2.0\text{V}, R_I = 75\Omega, I_{ON} = 26\text{mA}$	4.5		5	7	
I_{CC}	Quiescent Supply Current	$V_{IN} = V_{CC}$ or GND, $I_{OUT} = 0$	5.5			1	μA
ΔI_{CC}	Increase in I_{CC} per Input	One Input at 3.4V Other Inputs at V_{CC} or GND	5.5			1.5	mA

Note:

3. Measured by the voltage drop between the A and B pins at the indicated current through the switch. On resistance is determined by the lower of the voltages on the A or B pins.

AC Electrical Characteristics

Typical values are at $V_{CC} = 5.0\text{V}$ and $T_A = +25^\circ\text{C}$.

Symbol	Parameter	Conditions	V_{CC}	$T_A = -40$ to $+85^\circ\text{C}$			Units	Figure
				Min.	Typ.	Max.		
t_{ON}	Turn On Time S to Bus B	$V_B = 2\text{V}$	4.5 to 5.5		4.0	6.0	ns	Figure 11, Figure 12
	Output Enable Time OE to A or B				3.5	5.5		
t_{OFF}	Turn Off Time S to Bus B	$V_B = 2\text{V}$	4.5 to 5.5		1.5	3.5	ns	Figure 11, Figure 12
	Output Disable Time OE to A or B				1.5	3.5		
D_G	Differential Gain	$R_L = 75\Omega, f = 3.58\text{MHz}$	4.5 to 5.5		0.2		%	Figure 5
D_P	Differential Phase	$R_L = 75\Omega, f = 3.58\text{MHz}$	4.5 to 5.5		0.1		$^\circ$	Figure 6
O_{IRR}	Non-Adjacent Off Isolation	$R_L = 75\Omega, f = 30\text{MHz}$	4.5 to 5.5		-50		dB	Figure 7, Figure 13
X_{TALK}	Non-Adjacent Channel Crosstalk	$R_L = 75\Omega, f = 30\text{MHz}$	4.5 to 5.5		-80		dB	Figure 8, Figure 14
B_W	-3dB Bandwidth	$R_L = 50\Omega$	4.5 to 5.5		800		MHz	Figure 4, Figure 15
		$R_L = 75\Omega$			650			

Capacitance

Typical values are at $T_A = +25^\circ\text{C}$.

Symbol	Parameter	Conditions	Typ.	Units
C_{IN}	Control Pin Input Capacitance	$V_{CC} = 0\text{V}$	3.0	pF
C_{ON}	A/B On Capacitance	$V_{CC} = 5.0\text{V}, /OE = 0\text{V}$	8.5	pF
C_{OFF}	Port B Off Capacitance	$V_{CC} = /OE = 5\text{V}$	3.0	pF

AC Characteristics

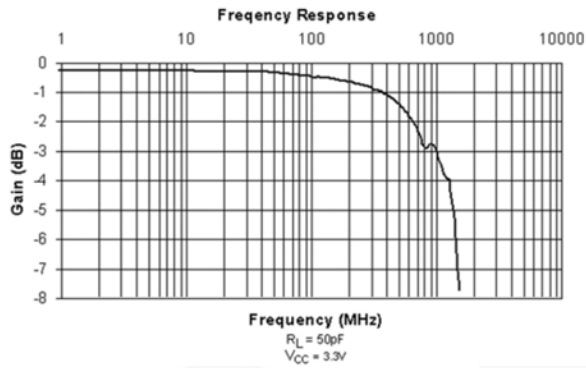

Figure 4. Gain vs. Frequency

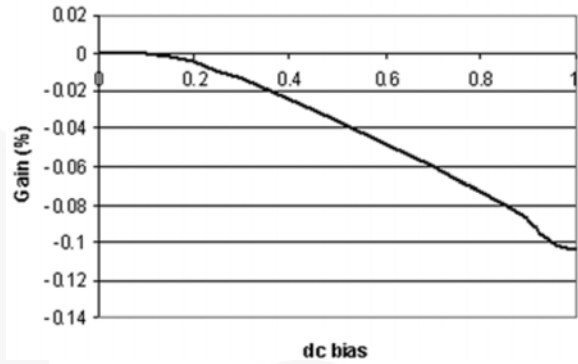

Figure 5. Differential Gain vs. DC bias

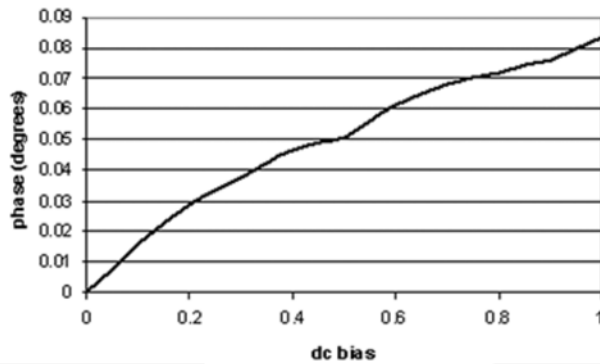

Figure 6. Differential Gain vs. DC bias

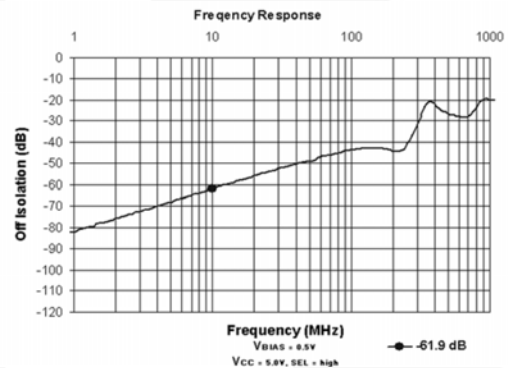

Figure 7. Off Isolation

AC Characteristics

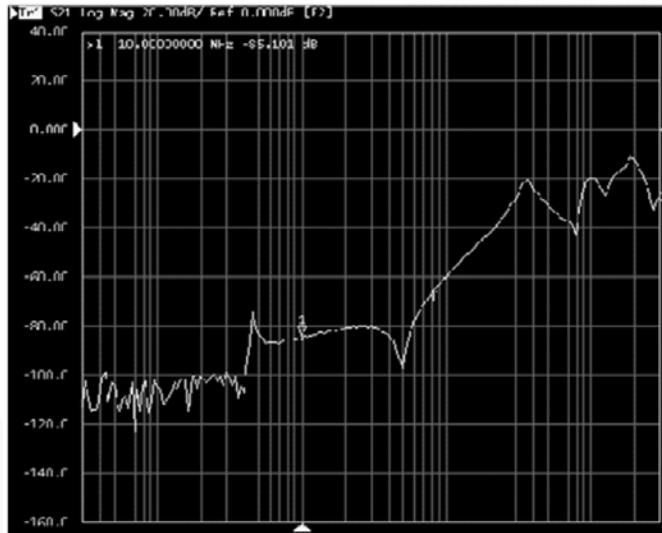

Figure 8. Off Crosstalk vs. Frequency

R_{ON} Switch Characteristics

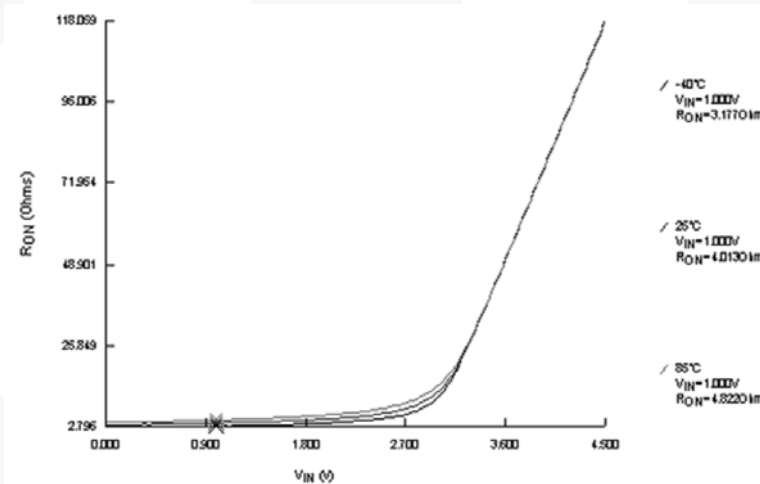

Figure 9. R_{ON} Switch On Resistance, I_{ON}=13mA

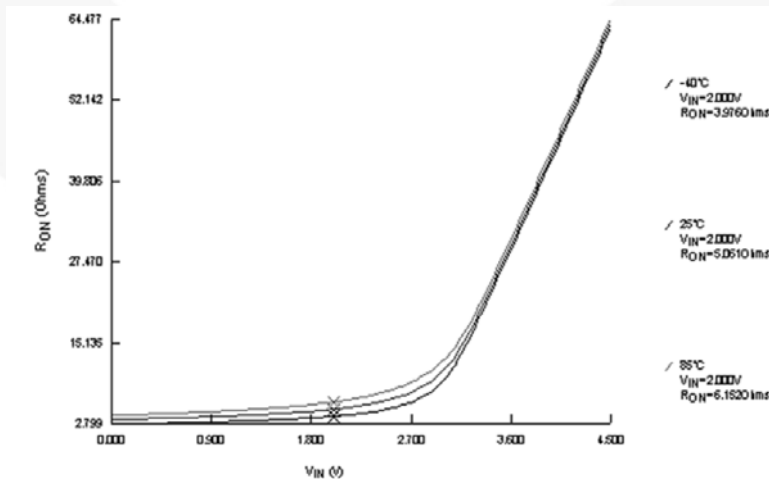
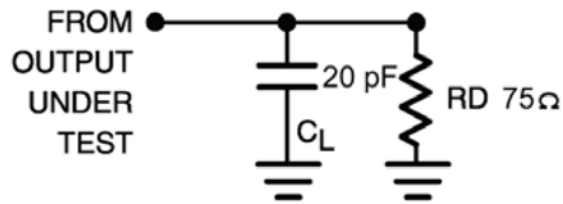

Figure 10. R_{ON} Switch On Resistance, I_{ON}=26mA

AC Loadings and Waveforms



Notes:

4. Input drive by 50Ω source terminated in 50Ω .
5. C_L includes load and stray capacitance.
6. Input PRR=1.0MHz, $t_W=500\text{ns}$.

Figure 11. AC Test Circuit

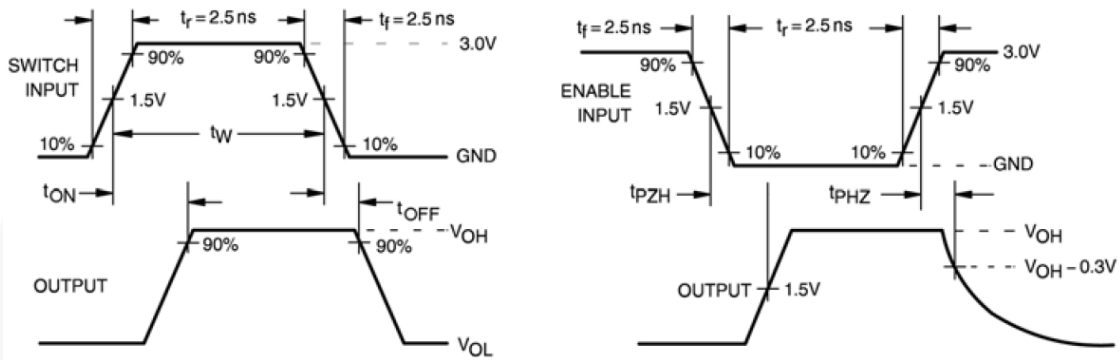

Figure 12. AC Waveforms

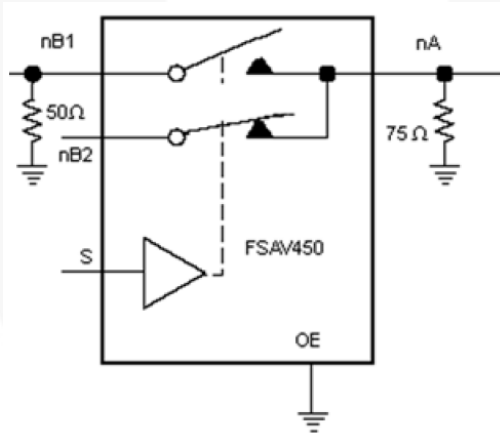

Figure 13. Off Isolation Test

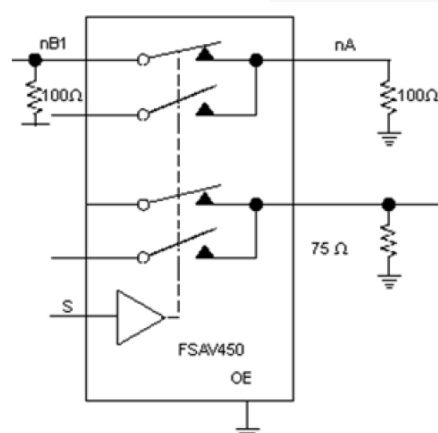

Figure 14. Crosstalk

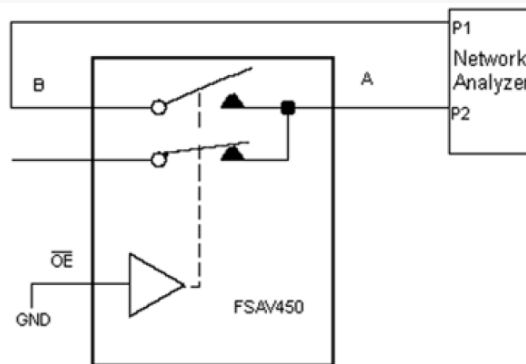
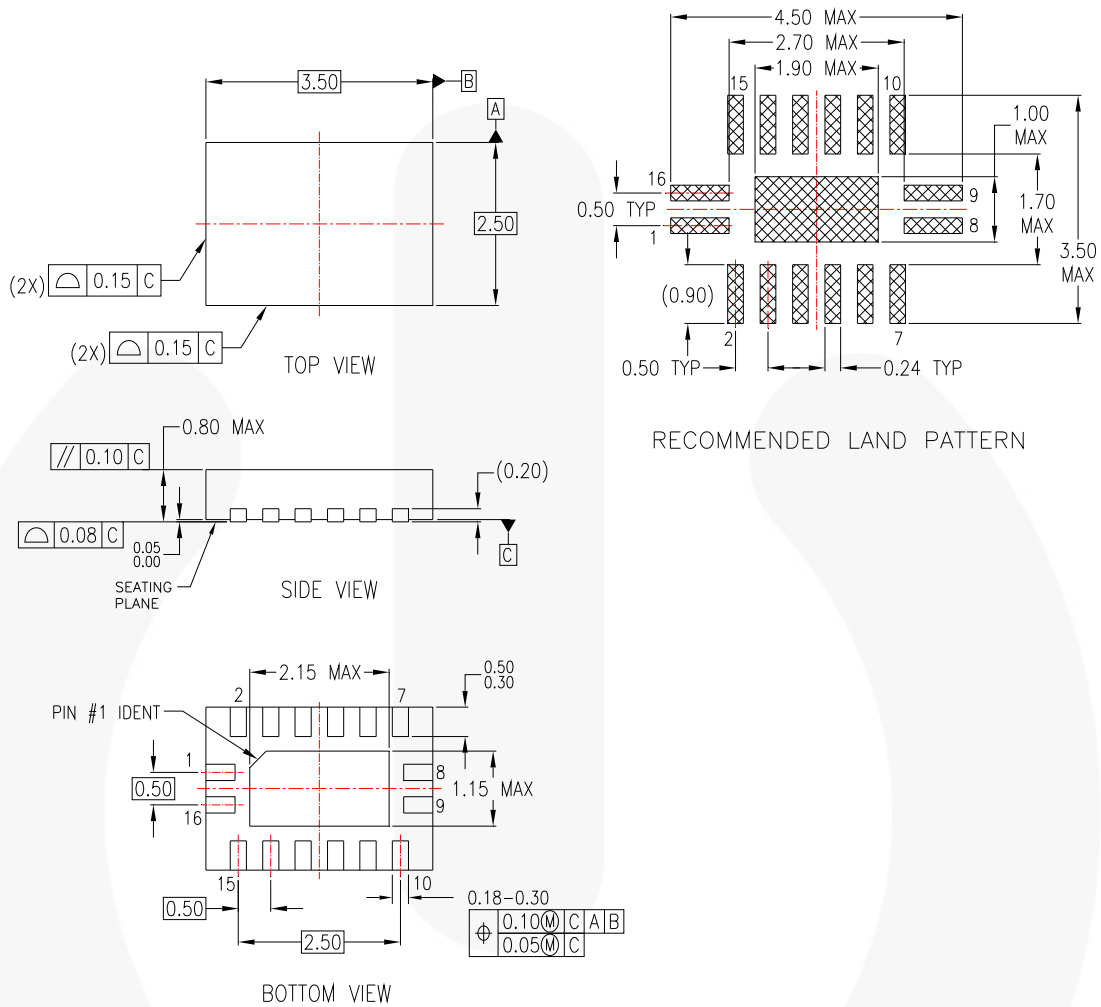

Figure 15. Bandwidth

Physical Dimensions



NOTES:

- A. CONFORMS TO JEDEC REGISTRATION MO-241, VARIATION AB
- B. DIMENSIONS ARE IN MILLIMETERS.
- C. DIMENSIONS AND TOLERANCES PER ASME Y14.5M, 1994

MLP16ErevA

Figure 16. 16-Terminal Depopulated Quad Very-Thin Flat Pack No Leads (DQFN), JEDEC MO-241

Package drawings are provided as a service to customers considering Fairchild components. Drawings may change in any manner without notice. Please note the revision and/or date on the drawing and contact a Fairchild Semiconductor representative to verify or obtain the most recent revision. Package specifications do not expand the terms of Fairchild's worldwide terms and conditions, specifically the warranty therein, which covers Fairchild products.





Always visit Fairchild Semiconductor's online packaging area for the most recent package drawings:
<http://www.fairchildsemi.com/packaging/>

For current tape and reel specifications, visit Fairchild Semiconductor's online packaging area:
<http://www.fairchildsemi.com/ms/MS/MS-522.pdf>



TRADEMARKS

The following includes registered and unregistered trademarks and service marks, owned by Fairchild Semiconductor and/or its global subsidiaries, and is not intended to be an exhaustive list of all such trademarks.

- | | | | |
|---|---|---|---|
| AccuPower™ | F-PFS™ | Power-SPM™ | The Power Franchise® |
| Auto-SPM™ | FRFET® | PowerTrench® | The Right Technology for Your Success™ |
| AX-CAP™* | Global Power Resource™ | PowerXS™ | the power franchise |
| Build it Now™ | Green FPST™ | Programmable Active Droop™ | TinyBoost™ |
| CorePLUS™ | Green FPST™ e-Series™ | QFET® | TinyBuck™ |
| CorePOWER™ | Gmax™ | QS™ | TinyCalc™ |
| CROSSVOLT™ | GTO™ | Quiet Series™ | TinyLogic® |
| CTL™ | IntelliMAX™ | RapidConfigure™ | TINYOPTO™ |
| Current Transfer Logic™ | ISOPLANAR™ |  ™ | TinyPower™ |
| DEUXPEED® | MegaBuck™ | Saving our world, 1mVW/kW at a time™ | TinyPWM™ |
| Dual Cool™ | MI CROCOUPLER™ | SignalWise™ | TinyWire™ |
| EcoSPARK® | MicroFET™ | SmartMax™ | TnFault Detect™ |
| EfficientMax™ | MicroPak™ | SMART START™ | TRUECURRENT®* |
| ESBC™ | MicroPak2™ | SPM® | µSerDes™ |
|  ™ | MillerDrive™ | STEALTH™ |  ™ |
| Fairchild® | MotionMax™ | SuperFET® | UHC® |
| Fairchild Semiconductor® | Motion-SPM™ | SuperSOT™-3 | Ultra FRFET™ |
| FACT Quiet Series™ | mWSaver™ | SuperSOT™-6 | UniFET™ |
| FACT® | OptoHit™ | SuperSOT™-8 | VCX™ |
| FAST® | OPTOLOGIC® | SupreMOS® | VisualMax™ |
| FastvCore™ | OPTOPLANAR® | SynCFET™ | XST™ |
| FETBench™ |  ™ | SynC-Lock™ | |
| FlashWriter®* | PDP SPM™ |  ™ | |
| FPST™ | | | |

* Trademarks of System General Corporation, used under license by Fairchild Semiconductor.

DISCLAIMER

FAIRCHILD SEMICONDUCTOR RESERVES THE RIGHT TO MAKE CHANGES WITHOUT FURTHER NOTICE TO ANY PRODUCTS HEREIN TO IMPROVE RELIABILITY, FUNCTION, OR DESIGN. FAIRCHILD DOES NOT ASSUME ANY LIABILITY ARISING OUT OF THE APPLICATION OR USE OF ANY PRODUCT OR CIRCUIT DESCRIBED HEREIN; NEITHER DOES IT CONVEY ANY LICENSE UNDER ITS PATENT RIGHTS, NOR THE RIGHTS OF OTHERS. THESE SPECIFICATIONS DO NOT EXPAND THE TERMS OF FAIRCHILD'S WORLDWIDE TERMS AND CONDITIONS, SPECIFICALLY THE WARRANTY THEREIN, WHICH COVERS THESE PRODUCTS.

LIFE SUPPORT POLICY

FAIRCHILD'S PRODUCTS ARE NOT AUTHORIZED FOR USE AS CRITICAL COMPONENTS IN LIFE SUPPORT DEVICES OR SYSTEMS WITHOUT THE EXPRESS WRITTEN APPROVAL OF FAIRCHILD SEMICONDUCTOR CORPORATION.

As used herein:

- Life support devices or systems are devices or systems which, (a) are intended for surgical implant into the body or (b) support or sustain life, and (c) whose failure to perform when properly used in accordance with instructions for use provided in the labeling, can be reasonably expected to result in a significant injury of the user.
- A critical component in any component of a life support, device, or system whose failure to perform can be reasonably expected to cause the failure of the life support device or system, or to affect its safety or effectiveness.

ANTI-COUNTERFEITING POLICY

Fairchild Semiconductor Corporation's Anti-Counterfeiting Policy. Fairchild's Anti-Counterfeiting Policy is also stated on our external website, www.fairchildsemi.com, under Sales Support.

Counterfeiting of semiconductor parts is a growing problem in the industry. All manufacturers of semiconductor products are experiencing counterfeiting of their parts. Customers who inadvertently purchase counterfeit parts experience many problems such as loss of brand reputation, substandard performance, failed applications, and increased cost of production and manufacturing delays. Fairchild is taking strong measures to protect ourselves and our customers from the proliferation of counterfeit parts. Fairchild strongly encourages customers to purchase Fairchild parts either directly from Fairchild or from Authorized Fairchild Distributors who are listed by country on our web page cited above. Products customers buy either from Fairchild directly or from Authorized Fairchild Distributors are genuine parts, have full traceability, meet Fairchild's quality standards for handling and storage and provide access to Fairchild's full range of up-to-date technical and product information. Fairchild and our Authorized Distributors will stand behind all warranties and will appropriately address any warranty issues that may arise. Fairchild will not provide any warranty coverage or other assistance for parts bought from Unauthorized Sources. Fairchild is committed to combat this global problem and encourage our customers to do their part in stopping this practice by buying direct or from authorized distributors.

PRODUCT STATUS DEFINITIONS

Definition of Terms

Datasheet Identification	Product Status	Definition
Advance Information	Formative / In Design	Datasheet contains the design specifications for product development. Specifications may change in any manner without notice.
Preliminary	First Production	Datasheet contains preliminary data; supplementary data will be published at a later date. Fairchild Semiconductor reserves the right to make changes at any time without notice to improve design.
No Identification Needed	Full Production	Datasheet contains final specifications. Fairchild Semiconductor reserves the right to make changes at any time without notice to improve the design.
Obsolete	Not In Production	Datasheet contains specifications on a product that is discontinued by Fairchild Semiconductor. The datasheet is for reference information only.

Rev. 153