

S67120X1.DGN

67120-****

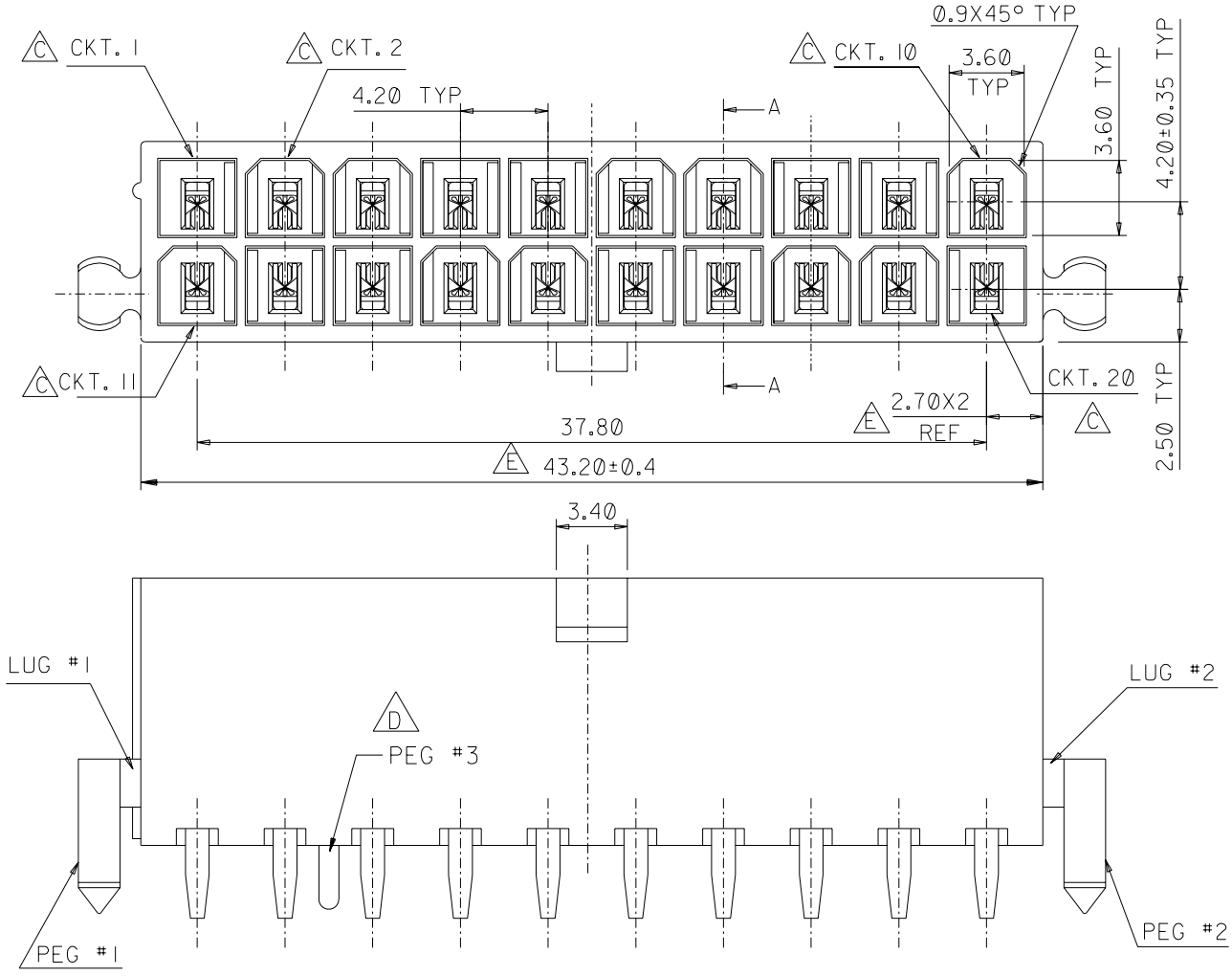

W/ MOUNTING PEG OPTION

- NOTES:
1. HOUSING: NYLON, UL 94V-2, COLOR : IVORY OR NATURAL
 2. TERMINAL: BRASS
PLATING : PRE-TINNED
TIN THICKNESS: 0.90um MIN.
COPPER THICKNESS: 0.50um MIN.
 3. ONLY PRODUCTS WITH DRAIN HOLES ARE AVAILABLE
 4. THE PRODUCT SPECIFICATION REFER TO "5566" SERIES OF PS-5556-001.
 5. P/N LEGEND: (SEE CHART (SHEET2)

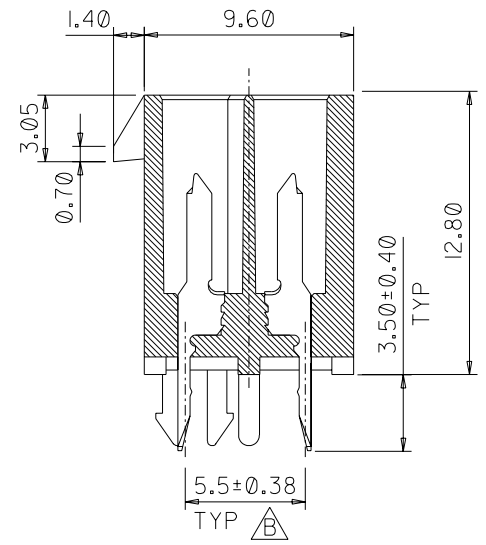

SECTION A-A

2	D
1	E

F	MODIFY PLATING EC NO. T2001-0197 DRAW: Eric Kao 02/03/05 CH'K: Wilson Chang 02/03/05 APPR: Erick Lan 02/03/05
F	ADD DIM. EC NO. T2001-0197 DRAW: S.HUANG 01/07/02 CH'K: Wilson Chang APPR: M.LAI
D	ADD PEG #3 EC NO. T2000-0118 DRAW: G.Wang 00/03/02 CH'K: Wilson Chang APPR: Mega Lin
C	ADDED P/N: 67120-0017 EC NO. T99-085 DRWN: EMILY 98/10/06 CH'K: HEKTOR APPR: WALLY

4:1
 Eric Kao 02/03/05
 Wilson Chang 02/03/05
 Erick Lan 02/03/05

ASSEMBLY DRAWING FOR MINI FIT JR

8 | 7 | 6 | 5 | 4 | 3 | 2 | 1

ENG. NO 67120-****

EDP NO.

S67120X2.DGN
CADFILE No.
SIMILAR ITEM

DO NOT SCALE DRAWING

P/N	CKT	HSG MATERIAL	UL	COLOR	PLATING	DRAIN HOLES	PEG 1	PEG 2	PEG 3	LUG 1	LUG 2	MEMO
67120-0020	20	NYLON 6/6	94 V-2	IVORY	PRE-PLATED	YES	YES	YES	NO	YES	YES	
67120-1020	20	NYLON 6/6	94 V-2	IVORY	PRE-PLATED	YES	NO	NO	NO	NO	NO	
67120-2020	20	NYLON 6/6	94 V-2	IVORY	PRE-PLATED	YES	YES	NO	NO	YES	YES	
67120-3020	20	NYLON 6/6	94 V-2	IVORY	PRE-PLATED	YES	NO	YES	NO	YES	YES	CKT.19 VOIDED
67120-4020	20	NYLON 6/6	94 V-2	IVORY	PRE-PLATED	YES	NO	NO	NO	YES	YES	
67120-0017	20	NYLON 6/6	94 V-2	IVORY	PRE-PLATED	YES	YES	YES	NO	YES	YES	CKT.1, 2 ,11, VOIDED
67120-5020	20	NYLON 6/6	94 V-2	NATURAL	PRE-PLATED	YES	NO	NO	YES	NO	NO	

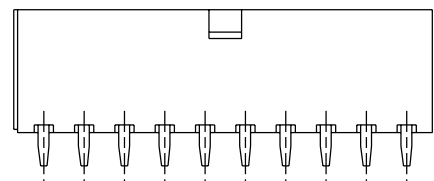

W/O MOUNTING PEG OPTION

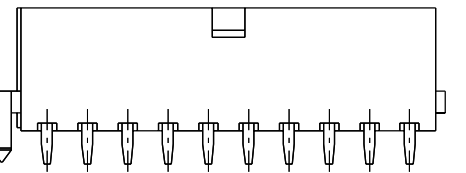
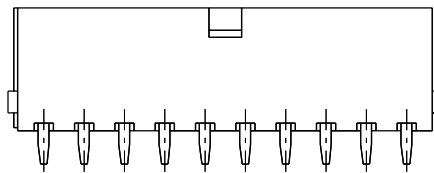
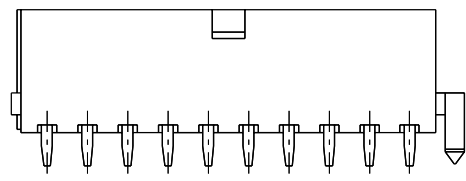

OPTIONS

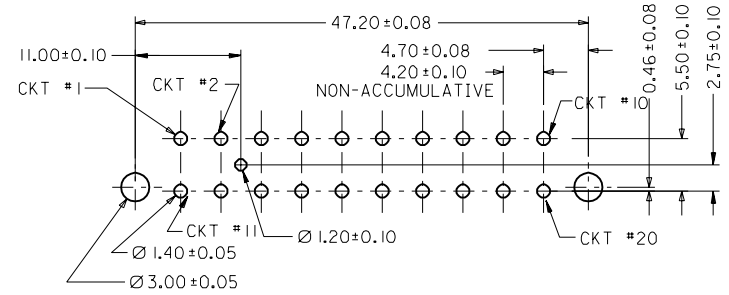

RECOMMENDED HOLE LAYOUT FOR 1.78 MAX. THICKNESS P.C.B.

SCALE 2 : 1

ADD PEG #3 EC NO. T2000-0118 DRAW:G.Wang 00/03/02 CHK: Wilson Chang APPR: Mega Lin	ADDED P/N: 67120-0017 EC NO. T99-085 DRAW: EMILY 98/10/06 CHK: HEKTOR APPR: WALLY	RTM EC NO. T98-137 DRAW: EMILY 98/10/06 CHK: HEKTOR APPR: N.K HUANG	PER EWR GC98-030 EC NO. T98-094 DRAW: NICKY 970902 CHK: BRUCE APPR: WILSON	PER PDR 1187 & PDR2000 EC NO. T97-458 DRAW: NICKY 970623 CHK: BRUCE APPR: WILSON	PER ECN EC NO. T97-363 DRAW: DAVID TSENG 970421 CHK: BRUCE 971016 APPR: WILSON
D	C	B	A2	A1	A

QUALITY SYMBOLS MAJOR : 0 CRITICAL : 0	GENERAL TOLERANCES: (UNLESS SPECIFIED)	SCALE 4:1	DESIGN UNITS <input checked="" type="checkbox"/> mm <input type="checkbox"/> INCH	DIMENSIONS: <input type="checkbox"/> mm <input type="checkbox"/> INCH <input type="checkbox"/> mm ONLY <input type="checkbox"/> mm ONLY	SHT 2	REV REVISE ON CAD ONLY
	4 PLACES ±0.10 3 PLACES ±0.10 2 PLACES ±0.25 ±0.10 1 PLACE ±0.25 ±0.10 ANGULAR: ±3°	DRAWN BY & DATE DAVID TSENG CHECKED BY & DATE APPROVED BY & DATE	THIRD ANGLE PROJECTION		TITLE: ASSEMBLY DRAWING FOR MINI FIT JR	
DRAFT WHERE APPLICABLE MUST REMAIN WITHIN DIMENSIONS	CAD FILENAME S67120X2.DGN	MATERIAL NO. SEE TABLE	DRAWING NO. SD-67120-****	SHEET NO. 2		
THIS DRAWING CONTAINS INFORMATION THAT IS PROPRIETARY TO MOLEX INCORPORATED AND SHOULD NOT BE USED WITHOUT WRITTEN PERMISSION.					SIZE A3	MOLEX INCORPORATED

F
E
D
C
B
A

ENG. NO SDA-67120-****

EDP. NO.

SIMILAR ITEM

CAD FILE : S67120X1

DO NOT SCALE DRAWING

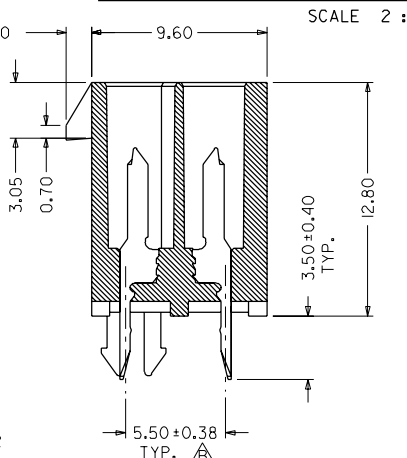
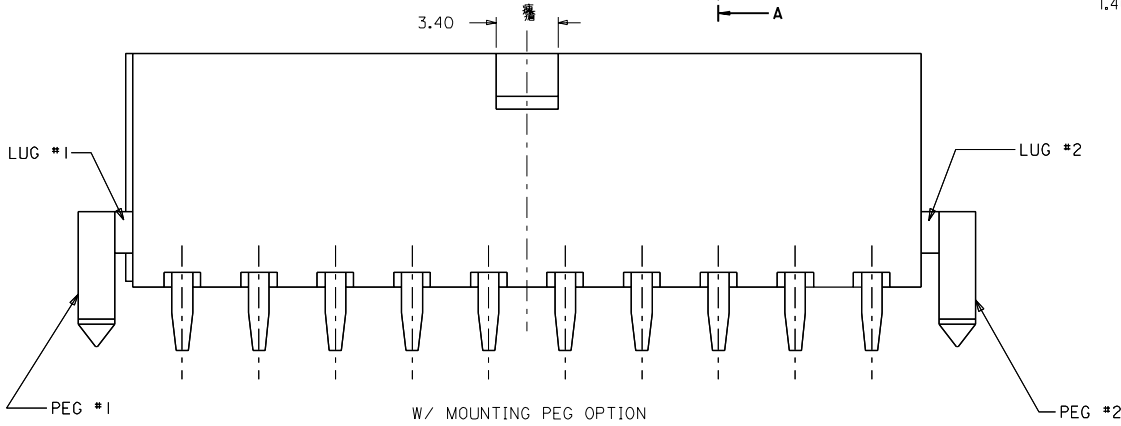
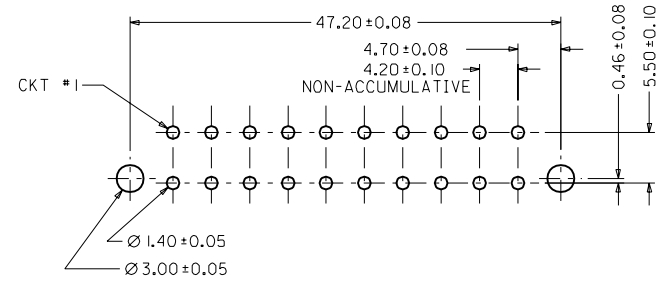
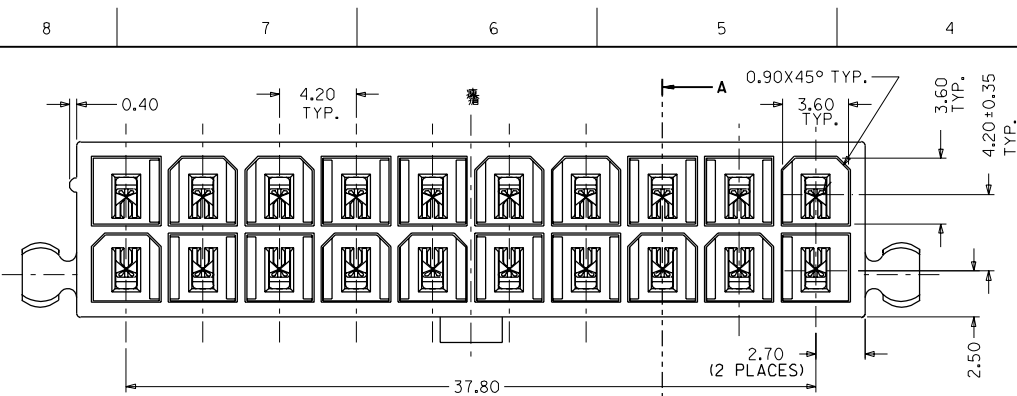

SECTION A-A

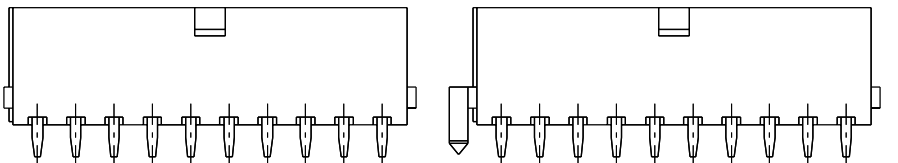
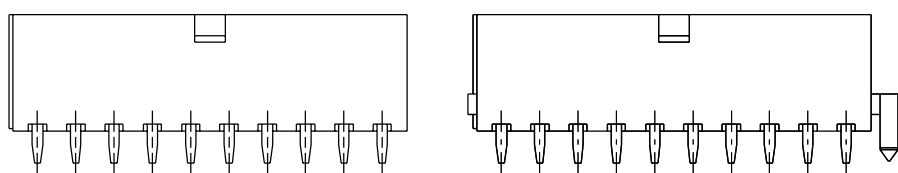

OPTIONS

NOTES:

- 1. HOUSING: NYLON, UL94 V-2 COLOR : IVORY
- 2. TERMINAL: BRASS
PLATING : PRE-TINNED
TIN THICKNESS : 90 um MIN. NICKEL THICKNESS : 50 um MIN.
- 3. ONLY PRODUCTS WITH DRAIN HOLES ARE AVAILABLE
- 4. PLEASE REFER TO '5566' SPEC.

P/N LEGEND:

PLEASE SEE CHART (SHEET 2)

				MATERIAL : SEE NOTES			MOLEX TAIWAN LTD.	
				FINISH : SEE NOTES			SHEET 1 OF 2	
B	RTM	198-137	NICKEL	971009	PRE RANGE :	GENERAL TOLERANCES		
A2	PER EWR GC98-030	198-094	NICKEL	970902		ANGLE : ± 3° DIM : ± .25/.010		
A1	PER PDR 1187 & 2000	197-458	NICKEL	970624	INS. RANGE :	ENG. NO.:		
A	PER ECN T97-363	DAVID TSENG		970114		SDA-67120-****		
LTR	REVISION RECORD	ECN	DR	DATE	DRAWN BY DAVID TSENG	CHK'D BY	TITLE :	
					APPR'D BY	SCALE 4 : 1	SALES ASSEMBLY FOR MINI FIT JR120 CKTS)	

8

7

6

5

4

3

2

1

MINI FIT JR ASSEMBLY NUMBER

P/N	CKT	HSG MATERIAL	UL	PLATING	DRAIN HOLES	PEG 1	PEG 2	LUG 1	LUG 2	MEMO	CROSS REF.
A-67120-0020	20	NYLON	94 V-2	PRE-PLATED	YES	YES	YES	YES	YES		
A-67120-1020	20	NYLON	94 V-2	PRE-PLATED	YES	NO	NO	NO	NO		
A-67120-2020	20	NYLON	94 V-2	PRE-PLATED	YES	YES	NO	YES	YES		
A-67120-3020	20	NYLON	94 V-2	PRE-PLATED	YES	NO	YES	YES	YES	CKT #19 VOIDED	
A-67120-4020	20	NYLON	94 V-2	PRE-PLATED	YES	NO	NO	YES	YES		

ENG. NO SDA-67120-****

EDP NO.

SIMILAR ITEM

CAD FILE : S67120X2

DO NOT SCALE DRAWING

				MATERIAL : SEE NOTES		 MOLEX TAIWAN LTD. SHEET 2 OF 2	
				FINISH : SEE NOTES			
				WIRE RANGE : N/A		GENERAL TOLERANCES ANGLE : ± 3° DIM : ± .25/.010	
B RTM				198-137 NICK 971009		ENG. NO.: SDA-67120-****	
A2 PER EWR GC98-030				198-094 NICK 970908		REV B	
A1 PER PDR 1187 & 2000				197-458 NICK 970623			
LTR	REVISION RECORD	ECN	DR	DATE	DRAWN BY DAVID TSENG	CHK'D BY	TITLE : SALES ASSEMBLY FOR MINI FIT JR. (20 CKTS)
REVISE ONLY ON CAD SYSTEM					APPR'D BY	SCALE NONE	