

PART NAME: KNOB SCALE: 1:1 DATE: 3/3/92 DR. BY HD

THIS DRAWING IS THE PROPERTY OF DAVIES MOLDING COMPANY, IS SUBMITTED SOLELY AS A DESIGN OR ENGINEERING PROJECT. WE ACCEPT NO RESPONSIBILITY WHATSOEVER FOR THE PRACTICAL APPLICATION OF THE PIECES MADE TO THIS DESIGN.



DESIGNERS & MANUFACTURERS OF KNOBS, HANDLES, CASES & CUSTOM PLASTIC COMPONENTS

P/N	4230-A
M NO.	73
(E) CAVITY	4230
CORE	4230
(C) CORE BUSHING	4230-Y
SLEEVE BUSHING	4230-Y
SLEEVE	4230-Y
PIN BUSHING	4230-Y
PIN	4230-A
INSERT	I0528
(D)	
M NO.	FRAME 2
CAVITY	4230
CORE	4230
CORE PIN	4230-Y
SLEEVE	4230-Y
PIN	4230-A
INSERT	I0528
SHIM (BUTTON)	0.025
SHIM (PIN)	0.020

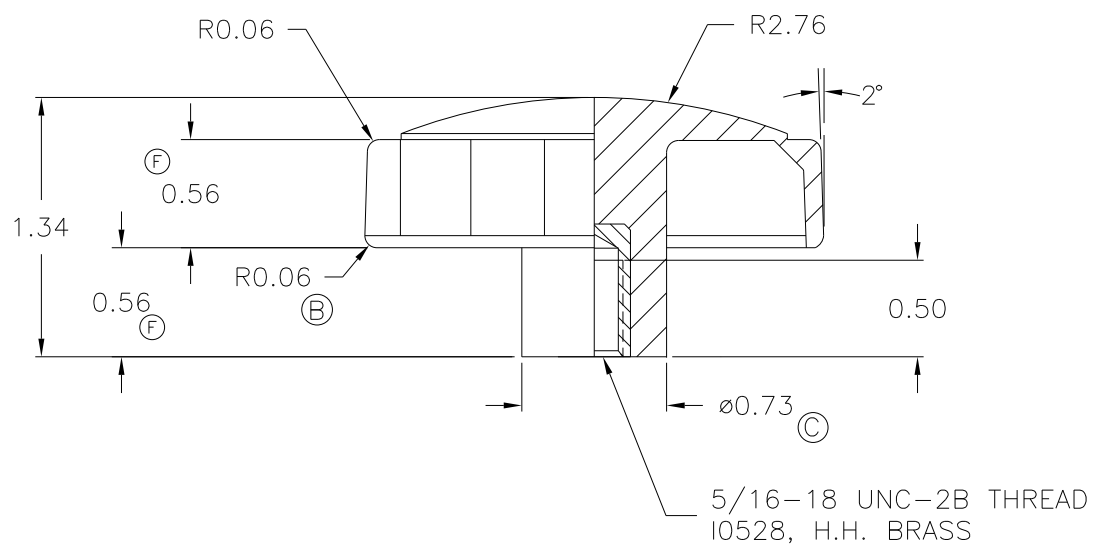
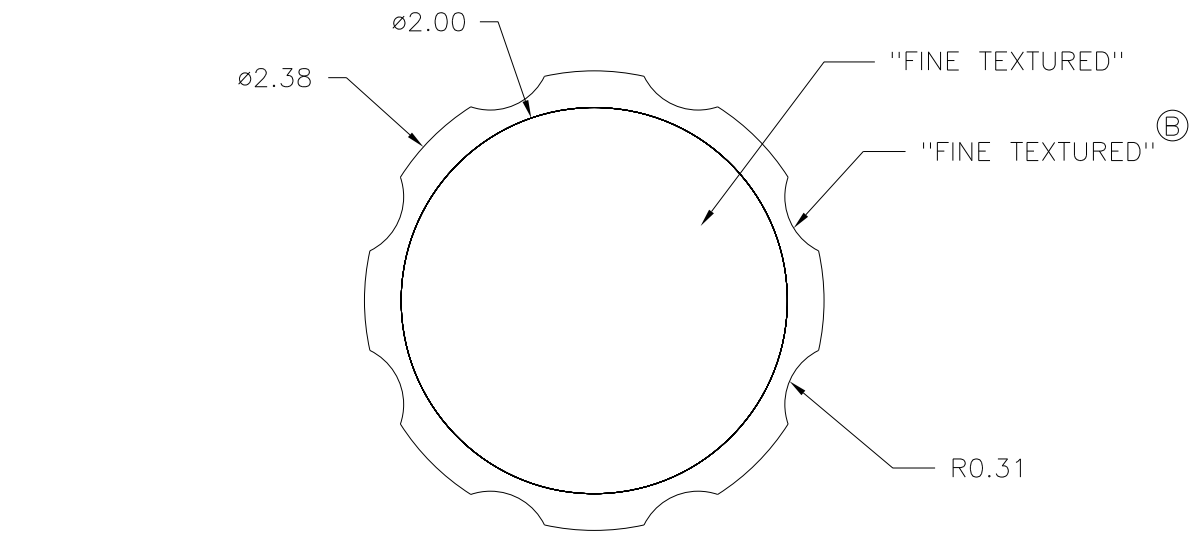

5/16-18 UNC-2B THREAD
I0528, H.H. BRASS

(B) MATERIAL: 20% TALC FILLED POLYPROPYLENE
COLOR: BLACK

(A)

TOLERANCES: UNLESS OTHERWISE SPECIFIED	DO NOT SCALE DRAWING
DECIMALS: X.XXX ± .005 X.XX ± .015	MM: X.XX ± 0.15MM X.X ± 0.4MM
FRACTIONS ± 1/64	ANG. ± 1°

F	UPDATED DIMENSIONS TO MATCH TOOLING	JAM	11/21/01
E	UPDATED TOOLBOX	JAM	10/8/01
D	ADDED FRAME 2 TOOLING BOX. REARRANGED PRINT CORRECTLY	TS	3/15/2001
C	WAS P/N# 4230-A. ADDED CORE BUSHING, WAS 1.25 DIA.HUB	HD	2/2/98
B	ADDED R0.06, TEXTURED WAS RE-6225,RE-6310, MAT'L WAS POLYPRO.	HD	1/28/98
A	ADDED NEW TOL. BLOCK	HD	6/12/96
-	CAD/REDRAWN	HD	6/28/94

CHANGES