

**Impact™
Mezzanine 85 Ohm
Vertical Header
Removal Tool**

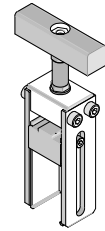

**Application Tooling
Specification Sheet**



Order No. 62100-2100

FEATURES

- Used in the removal of the Impact™ Mezzanine 85 Ohm Vertical Header Assembly from a PCB
- Removes header assemblies from the PCB without damage to the board
- Use tool 62201-8717 for 4 pair by 10 column for inserting header assemblies
- Use tool 62201-8718 for 4 pair by 18 column for inserting header assemblies

SCOPE

Products: Impact™ Mezzanine 85 Ohm Vertical Header 37mm Stack height (4-Pair Assemblies). See Product List below for specific application tools.

Product List

The following is a partial list of the product order numbers and their specifications this tool is designed to run. Updates to this list are available on www.molex.com.

Guide Style	Stack Height	4 Pair Assembly Order Number					
Left	37mm	170390-2030	170390-2039	170390-2130	170390-2139	170390-2230	170390-2239
		170390-2330	170390-2339	170390-2430	170390-2439	170390-2530	170390-2539
		170390-2630	170390-2639	170390-2730	170390-2739	170390-2830	170390-2839
		170390-3030	170390-3039	170390-3130	170390-3139	170390-3230	170390-3239
		170390-3330	170390-3339	170390-3430	170390-3439	170390-3530	170390-3539
		170390-3630	170390-3639	170390-3730	170390-3739	170390-3830	170390-3839

DESCRIPTION

The tool is used for removal of the Impact™ Mezzanine 85 Ohm Vertical Header Assemblies from a PCB. The principal parts of the terminal removal tool are shown in Figure 1.

Operation

Note: Be sure that all parts of the removal tool will clear any components on the printed circuit board during use. Tape may also be placed over circuit traces or on the bottom of the PC board Support Plate for added protection of the printed circuit board.

1. Turn the T Handle counter-clockwise (CCW) until the lifting fingers are exposed below the end supports. See Figure 2. (The stop screw will become disengaged from the lifting bar.)
2. Slide the lifting fingers down over the header assembly until the lifting fingers snap under the stiffeners on both sides of the header assembly. See Figure 2.

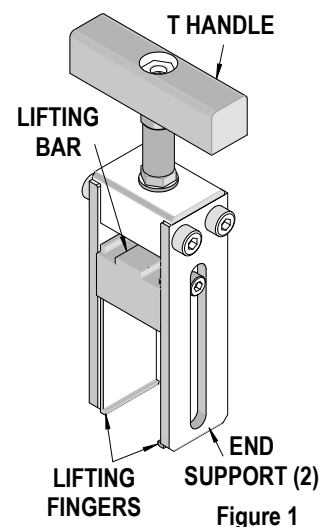
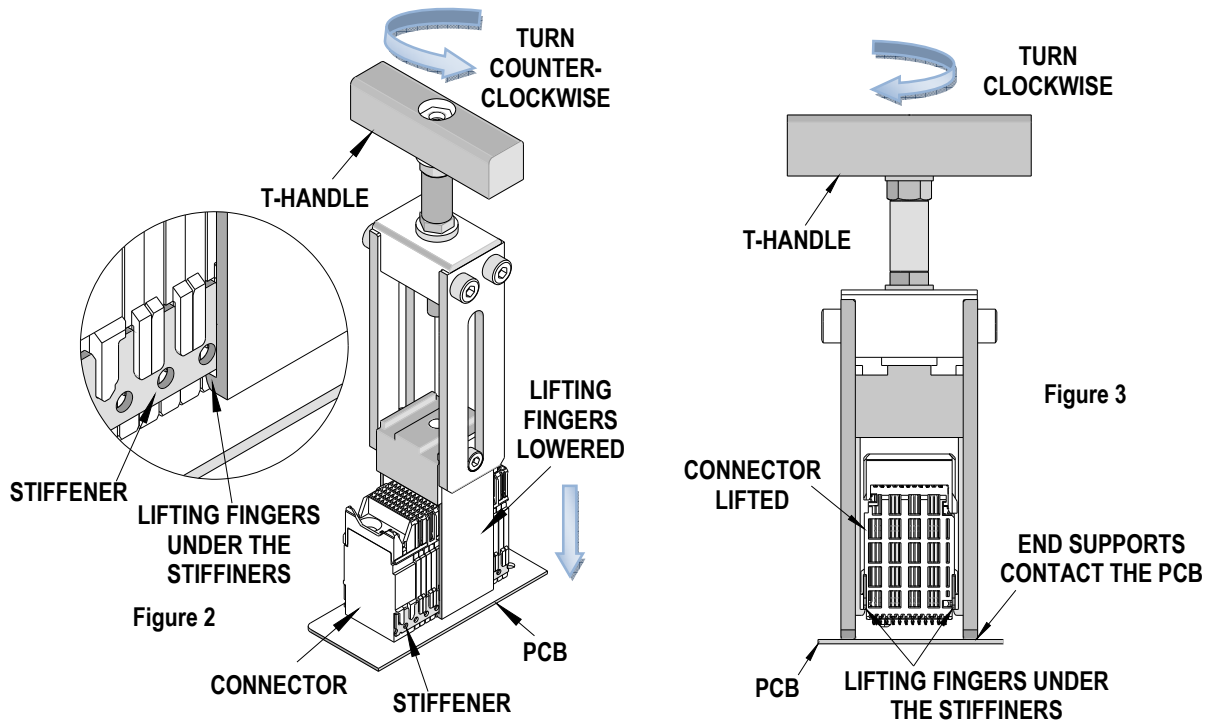

Figure 1

Note: The lifting fingers must snap under the stiffeners on each side of the header assembly so it can be lifted off the printed circuit board.

3. Lower the tool until the bottom of the end supports contact the printed circuit board surface.
4. Turn the T handle clockwise (CW) until the header assembly is removed from the PCB. See Figure 3.



Note: After removing the header assembly from the PCB, some terminals may remain in the board. This is not a tooling malfunction. A pair of needle nose pliers may be used to individually remove the terminals. Caution is required when using this method; if a terminal is incorrectly gripped or pulled away at an angle, it could break off inside the PCB hole. After terminals are pulled out of the PCB, they should be discarded. The PCB should be free of any contact debris.

5. With the removal tool away from the PCB, take the header assembly out of the tool by turning the T handle counterclockwise until the lifting fingers are exposed. Pull the header assembly up slightly and slide it out of the side of the tool.

Maintenance

It is recommended that each operator of the tool be made aware of, and responsible for, the following maintenance steps:

1. Remove dust, moisture, and other contaminants with a clean brush, or soft, lint free cloth.
2. Do not use any abrasive materials that could damage the tool.
3. Make certain all pins; pivot points and bearing surfaces are protected with a thin coat of high quality machine oil. Do not oil excessively.
4. When tool is not in use, store in a clean, dry area.

CAUTION: Molex specifications are valid only when used with Molex terminals, applicators and tooling.

Visit our Web site at <http://www.molex.com>