



C1 PRO

INDUSTRIAL USB CAMERA WITH CS LENS MOUNT AND H.
264 ON-BOARD ENCODER

DATASHEET



KUROKESU

2021-02-07, Rev. #29

Overview

C1 family camera **C1 PRO** with Sony Exmo R Starvis IMX290 sensor offers h.264/MHPEG/YUYV compressions over USB interface.



Features

- 1"-20TPI mount for CS lens
- Multiple mounting options (all side walls and top has M3 tapped holes) for machine vision or robotics
- 1/4-20 UNC thread for tripod mounting
- Format: 1/2.8-inch (6.46mm)
- Sensor: Sony IMX290
- MJPEG/h.264/YUY2 compression
- 1920x1080 @ 30fps
- UVC compatible
- Sensor pixel size: 2.9µm x 2.9µm
- Sensor dynamic range: 66db
- SNR max: 40.5db
- Operation temperature range: -50°C...+85°C
- USB 2.0
- Interchangeable filters ([shortpass 650nm](#) installed by default)
- High quality industrial black anodized aluminum case
- Non cropped sensor operation in all resolutions
- Each camera has unique serial number
- RoHS, REACH, CE certified

Specifications

Specifications

Pixels	1920H x 1080V
Sensor size	5.63 x 3.17 mm
Shutter	Electronic Rolling Shutter
Sensor pixel size	2.9µm x 2.9µm
Frame rates	<ul style="list-style-type: none"> • h.264 – 30fps in all modes • MJPG – 30fps in all modes • YUV 4:2:2 (YUYV) <ul style="list-style-type: none"> ◦ 1920x1080 – 5fps ◦ 1280x720 – 10fps ◦ 640x480 – 30fps
Output frame sizes	1920x1080, 1280x720, 640x480, 640x360, 320x240, 320x180
Scan	Progressive
Manual control	<ul style="list-style-type: none"> • Exposure • White balance (2800°K – 9300°K) • Gain • Gamma • Backlight compensation • Sharpnes • Contrast • Saturation • Hue • Brightness • Anti-flicker frequency
Rated power	<ul style="list-style-type: none"> • 2W max • 350mA @ 5V – h.264 • 290mA @ 5V – MJPEG / YUYV
Interchangeable filter	17x17x0.5mm. Low pass 650nm filter installed by default, high pass 850nm filter available on request, other filters also can be supplied on special order

Supported OS	<ul style="list-style-type: none"> • Windows • OSX • Linux • Android
Sensor	Sony IMX290
Weight	53g
Dimensions	40×40×23mm
Ingress protection	IP40
Lens mount	CS-mount
Operational temperature	-50 ... 85°C (non condensing)

Dimensions

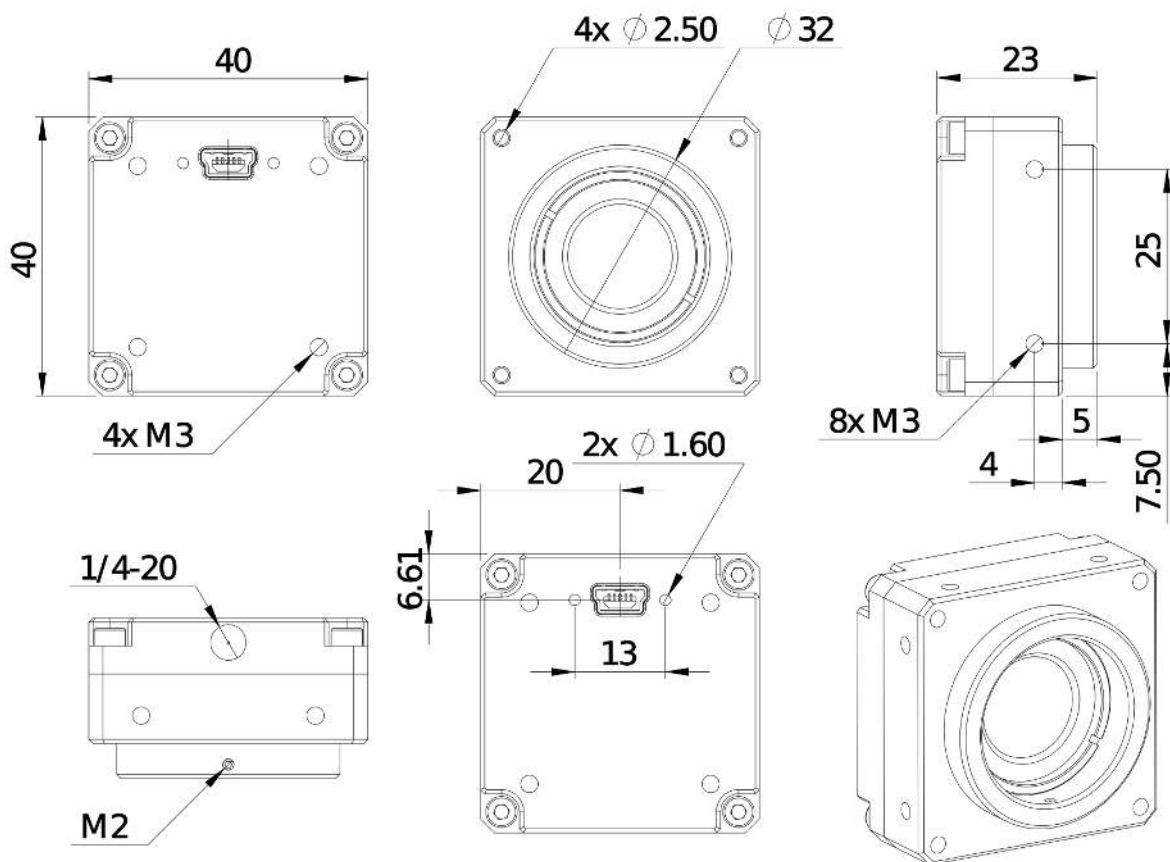

3D model

i Most of the Kurokesu product 3D models uploaded to [Github](#)