

REV.	DESCRIPTION	DATE	APPROVED
B	Engineering Update w/o Changes	02/23/04	M. C.
C	Tolerance Update	03/13/06	M. C.
D	Title Description Update	08/03/09	T. Y.
E	Removed Part From Part Offering List	09/28/15	J. C.
F	Removed Material Code	05/28/16	J. C.
G	Engineering Update w/o Changes	08/27/18	M. C.

## 909-235 XX

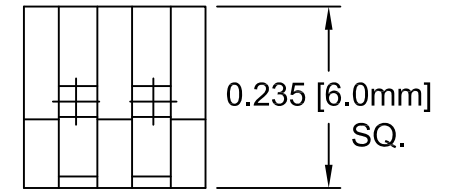

Ø.256 [Ø6.5mm] Recess feature to accept 905 series to add height.

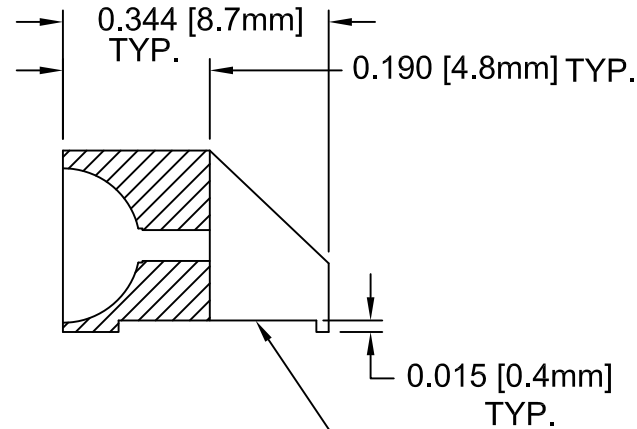
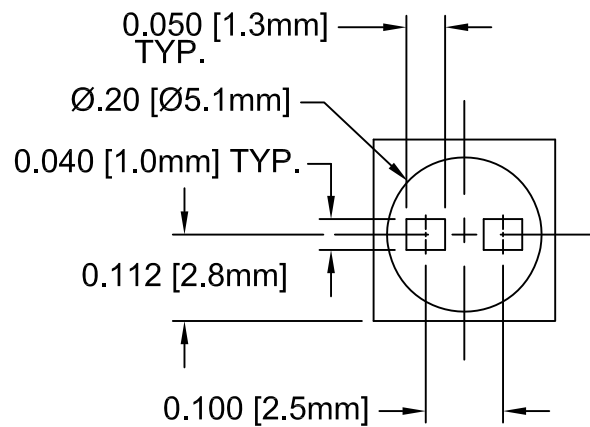
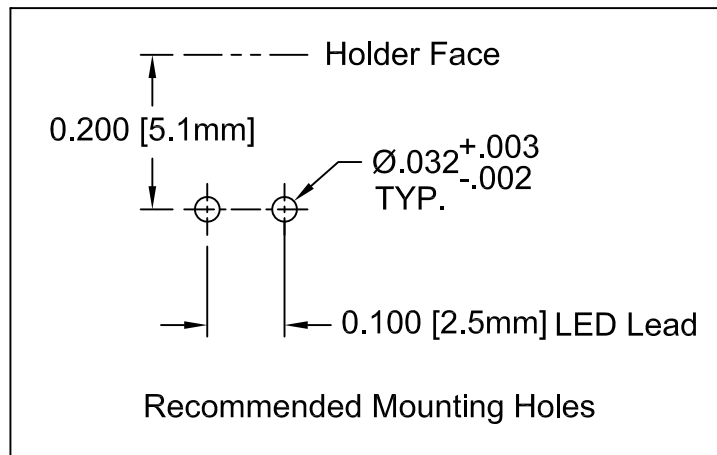

HOLDER	MATERIAL
909-235 NT	A
909-235 BK	B

3. MATERIAL B: NYLON 6/6, 94V-2, BLACK.

2. MATERIAL A: NYLON 6/6, 94V-2, NATURAL.

1. GENERAL SPECIFICATIONS: BIVAR MOLDED COMPONENT SPECIFICATION BV00-E101.

STANDARD TOLERANCE (UNLESS OTHERWISE SPECIFIED)		BIVAR®	
DECIMALS	ANGULAR	4 THOMAS, IRVINE, CA. 92618	
.X ±.1	X° ± 1°	TEL: (949) 951-8808 FAX: (949) 951-3974	
.XX ±.02		TITLE: SINGLE T1 3/4(5mm) LED HOLDER	
.XXX ±.010		PART NO: 909-235X XX	
DESIGNED: D. GREEN	DATE: 04/24/03	REVISION: G	
REVISED: D. GILBREATH	DATE: 08/27/18	CAGE CODE: 32559	
CHECKED: TD. NGUYEN	DATE: 08/27/18	SCALE: NONE	SHEET # 1 OF 1

CAD GENERATED DOCUMENT, DO NOT MEASURE DRAWING