

VICOR CONFIDENTIAL
 THIS DOCUMENT AND THE DATA DISCLOSED HEREIN OR
 HEREWITH IS NOT TO BE REPRODUCED, USED OR
 DISCLOSED IN WHOLE OR IN PART TO ANYONE WITHOUT
 THE PERMISSION OF VICOR CORP.

REVISIONS				
REV	DESCRIPTION	DATE	APPROVED	
1	RELEASED PER E050348	PEI 11/15/05	ECF	
2	REVISED PER E091652	JS 09/11/09	REJH	
3	REDRAWN PER E100871	DCS 6/29/10	KUK	

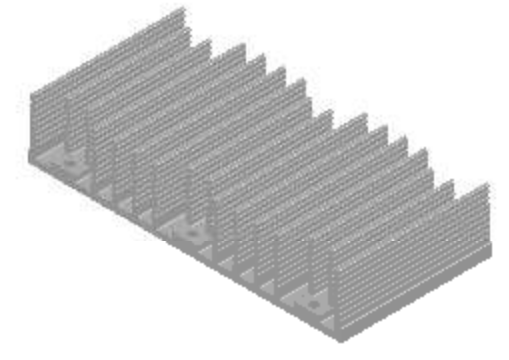
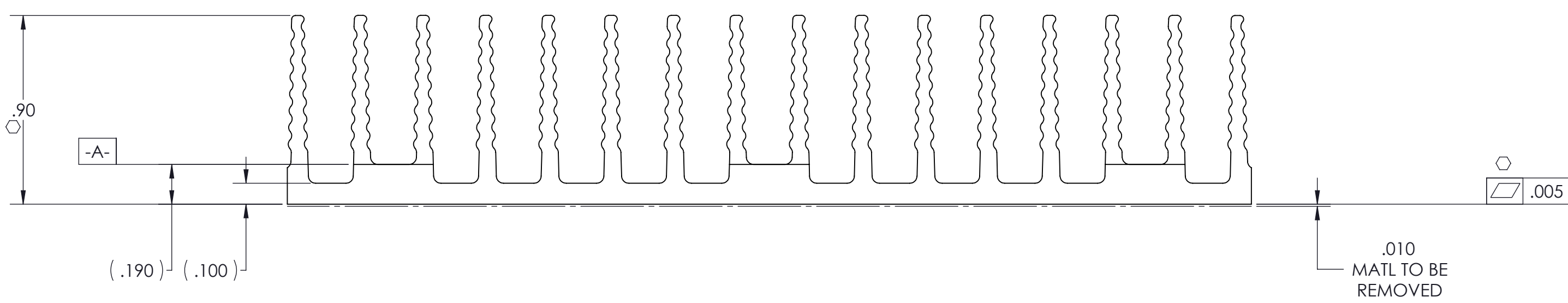
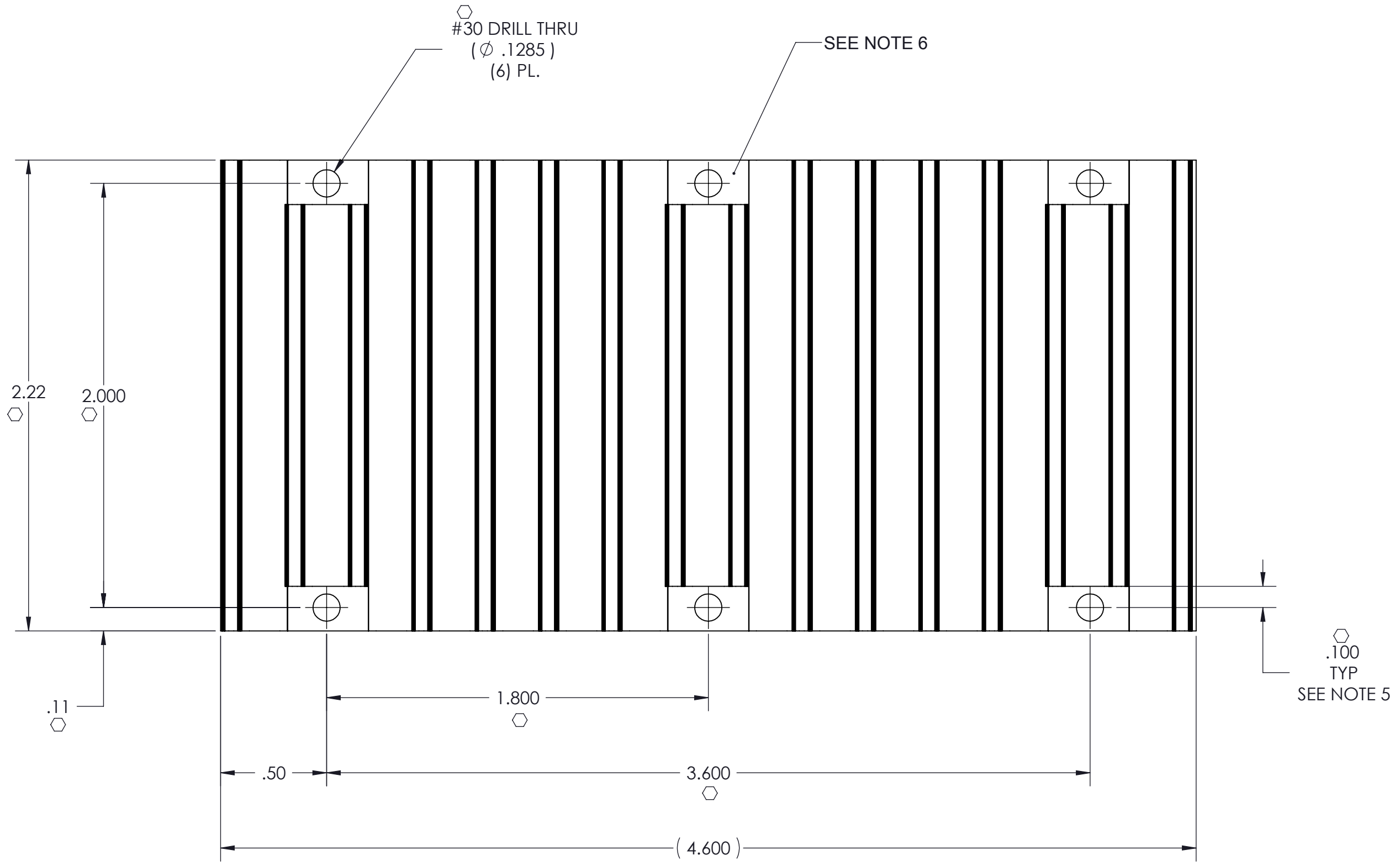

- NOTES:
1. MATERIAL; EXTRUSION SEE SHEET 2 OF 2.
 2. REMOVE ALL BURRS AND SHARP EDGES.
 3. CLEAR FINISH, RoHS COMPLIANT PER CST-0001 LATEST REVISION.
 4. "○" DENOTES CRITICAL CHARACTERISTIC FOR LOT INSPECTION.'
 5. DIMENSIONS APPLIES AT SURFACE -A- (2) PL.
 6. MACHINED SURFACE TO BE .010 MAX BELOW SURFACE -A- (60 PL.
 7. DIMENSIONS ARE INCHES ONLY.

DRAWN	DATE	VICOR SWD			
D.P. KELLY	05/97				
MATERIAL	UNLESS OTHERWISE SPECIFIED DIMENSIONS ARE INCH [MM]	HS CFG "A", .90H, X-FLOW, LOW FLOW, THRU HOLE			
SEE NOTES	TOLERANCES ARE: DECIMALS ANGLES X.XX [X.X] = ±0.01 [0.25] ±1° X.XXX [X.XXX] = ±0.005 [0.127]				
FINISH	THIRD ANGLE PROJECTION	SIZE	CAGE CODE	DWG NO	REV
SEE NOTES		C	67131	30723	3
		SCALE 2 : 1		SHEET 1 OF 2	

THIS DOCUMENT AND THE DATA DISCLOSED HEREIN OR HEREWITH IS NOT TO BE REPRODUCED, USED OR DISCLOSED IN WHOLE OR IN PART TO ANYONE WITHOUT THE PERMISSION OF VICOR CORP.

REV	DESCRIPTION	DATE	APPROVED
#1	DRAWN FOR DEVELOPMENT	XXX	MM/YY XXX

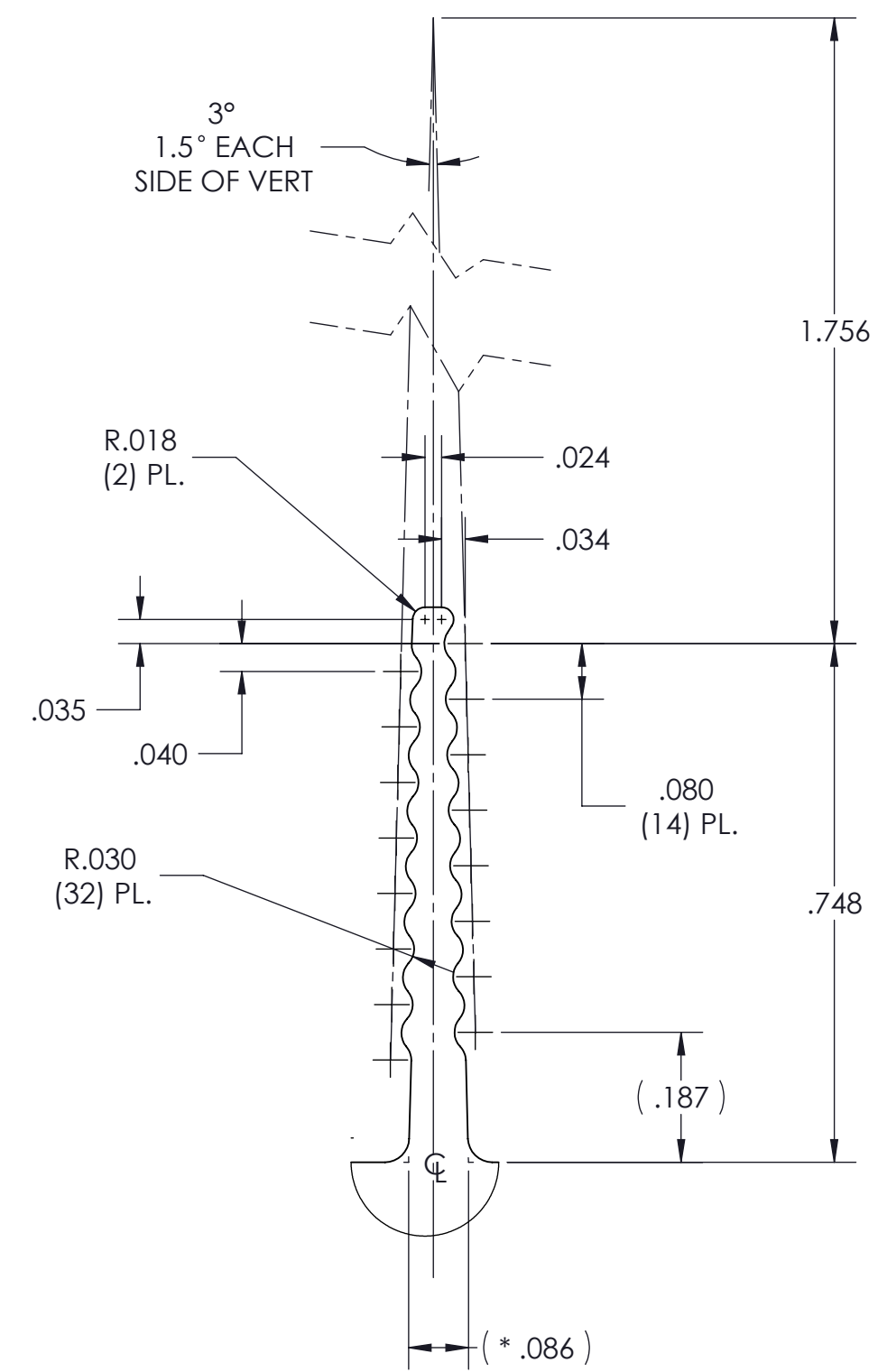
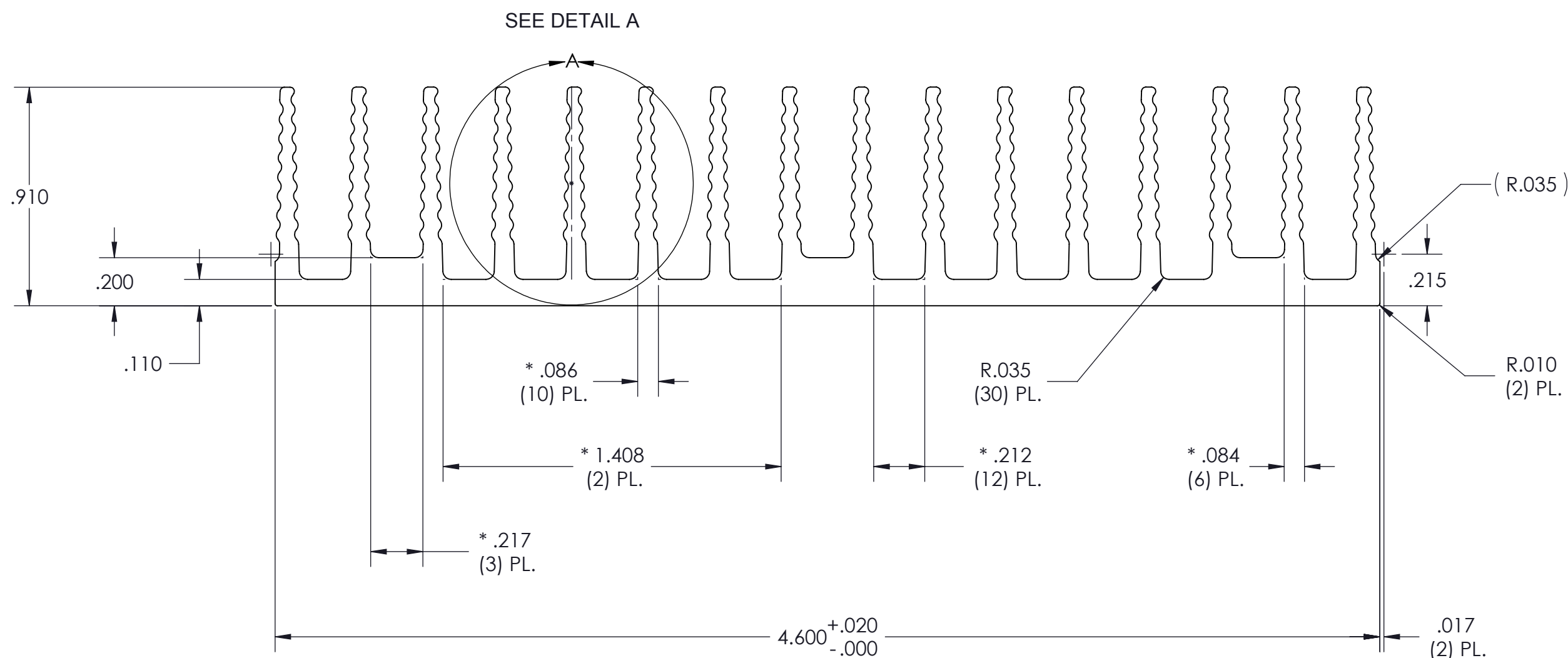

DETAIL A
SCALE 4 : 1

PROFILE COMMON FOR
30196
30723

NOTES:

- MATL; ALUMINUM 6063-T5
- * DENOTES DIMENSION TO THEORETICAL SHARP CORNER.
- ALL DIMENSIONS ARE CRITICAL CHARACTERISTICS.
- RoHS COMPLIANT PER CST-0001 LATEST REVISION.
- WORKMANSHIP STANDARDS WS-0004, WS-0006, AND WS-0007 APPLY TO THIS PART.
- DIMENSIONS ARE INCHES ONLY.

DRAWN	DATE	VICOR SWD			
JSARIPPELLA	09/11/09				
MATERIAL	UNLESS OTHERWISE SPECIFIED DIMENSIONS ARE INCH [MM]	HS CFG "A", .90H, X-FLOW, LOW FLOW, THRU HOLE, EXTRUSION			
SEE NOTES	TOLERANCES ARE: DECIMALS ANGLES X.XX [X.X] = ±0.01 [0.25] ±1° X.XXX [X.XX] = ±0.005 [0.127]				
FINISH	THIRD ANGLE PROJECTION	SIZE	CAGE CODE	DWG NO	REV
SEE NOTES		C	67131	30723	3
		SCALE 2 : 1		SHEET 2 OF 2	