

Using the Multi-Axis g-Select Evaluation Boards

by: Michelle Clifford and John Young
Applications Engineers
Tempe, AZ

INTRODUCTION

This application note describes the Accelerometer Evaluation Boards for Freescale's multi-axis g-Select accelerometers.

Accelerometer Part Number ⁽¹⁾	Selectable g-ranges	Axis	Evaluation Kit Part Number ⁽²⁾
MMA7260QT/R2	1.5g, 2g, 4g, 6g	XYZ-Axis	KIT3109MMA7260QE
MMA7261QT/R2	2.5g, 3.3g, 6.7g, 10g	XYZ-Axis	KIT3109MMA7261QE
MMA6270QT/R2	1.5g, 2g, 4g, 6g	XY-Axis	KIT3109MMA6270QE
MMA6271QT/R2	2.5g, 3.3g, 6.7g, 10g	XY-Axis	KIT3109MMA6271QE
MMA6280QT/R2	1.5g, 2g, 4g, 6g	XZ-Axis	KIT3109MMA6280QE
MMA6281QT/R2	2.5g, 3.3g, 6.7g, 10g	XZ-Axis	KIT3109MMA6281QE

NOTES:

- The "T" signifies parts shipped in trays. "R2" signifies parts shipped in tape and reel.
- The "E" signifies a RoHS compliant development tool.

The Accelerometer Evaluation Boards are small circuit boards intended to be used for evaluating the accelerometers and developing prototypes quickly without requiring a PCB to be designed to accommodate for the small profile QFN package. It also provides a means for understanding the best mounting position and location of an accelerometer in your product with provided board mounting points.

KIT3109 CIRCUIT DESCRIPTION

Figures 11 thru 13 are general circuit schematics of the evaluation boards. The recommended decoupling capacitor at the power source and recommended RC filter at each accelerometer output, are included on the evaluation board. For a complete description of the operation of the accelerometer, refer to the respective datasheet. There is an RC filter at each of the three accelerometer outputs in order to minimize clock noise that may be present from the switched capacitor filter circuit. No additional components are necessary to use the evaluation board.

The evaluation boards have pads for interfacing to a 3.3 V power source or battery. The pads on the side of the board also provide a means for connecting to the accelerometer analog output by soldering a wire from the evaluation board to another breadboard or system. The ON/OFF switch enables the power to the accelerometer and helps preserve battery life if a battery is being used as the power source. **S1** must be set towards the ON position for the accelerometer to function. The green LED labeled PWR is lit when power is supplied to the accelerometer.

G-SELECT DIPSWITCH SETTINGS

The g-Select is a powerful feature on this series of accelerometers allowing each single device to measure 4 different ranges of acceleration (see Table 1 and Table 2). The g-Select allows one device to provide multiple applications in one package. By adjusting the dip-switches on the evaluation board, the accelerometer can toggle between the different g-Ranges with the same accelerometer part. In application designs, the g-Select pins would be connected to I/O pins of a microcontroller. The following tables outline the g-Ranges that the values of the g-Select pins correspond to.

Table 1. g-Select Pin Descriptions for MMA7260QT, MMA6270QT, and MMA6280QT

g-Select2	g-Select1	g-Range	Sensitivity
0	0	1.5g	800 mV/g
0	1	2g	600 mV/g
1	0	4g	300 mV/g
1	1	6g	200 mV/g

Table 2. g-Select Pin Descriptions for MMA7261QT, MMA6271QT, and MMA6281QT

g-Select2	g-Select1	g-Range	Sensitivity
0	0	2.5g	480 mV/g
0	1	3.3g	360 mV/g
1	0	6.6g	180 mV/g
1	1	10g	120 mV/g

SLEEP MODE FUNCTION

The g-Select series accelerometers feature a sleep mode function, activated by a sleep mode option on the device's pinout. The sleep mode pin is an active high pin, enabling the device "on" when V_{DD} is applied to that pin (pin 12).

This is selectable on the evaluation board using either the INPUT/OUTPUT sleep mode Pad or the dip switch that is provided. When the dip switch is activated, the device is enabled. The same occurs with the Sleep Mode Pad. When the user attaches a 3.3 V or V_{DD} voltage to this, the device will be enabled. A V_{CC} connection to this pin will place the device in standby mode. If the device is enabled, the LED labeled sleep mode will be lit.

The sleep mode allows the accelerometer to operate on standby at 3 μA supply current. Regular operation uses 500 μA of supply current.

NOTE

Power Consumption is 3 μA during Sleep mode operation, and 500 μA during normal operation. Note that when verifying this information during prototyping, it is necessary to remove the LEDs from the Evaluation Board. These have been designed in to provide a clear indication of the part's states, but draw additional current as all items share the common input voltage terminal.

QUICK STARTUP GUIDE

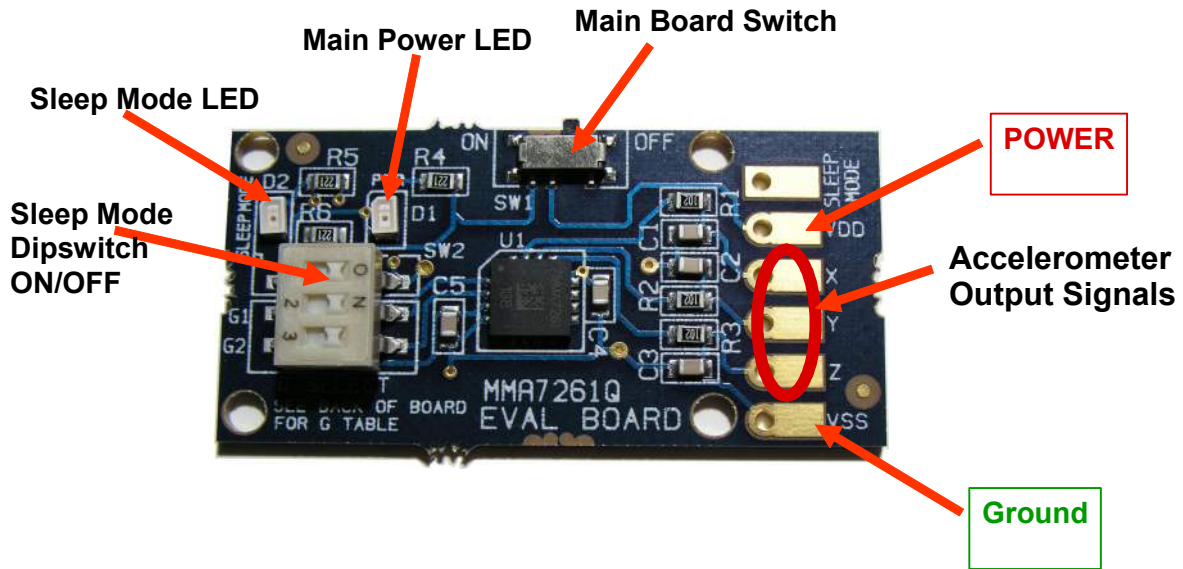

Figure 1. Evaluation Board Components for KIT3109

1. Connect the external power source to the Evaluation board. The 3.3 V input is connected to the POWER (V_{DD}) and Ground (V_{SS}) using the solder pads.
2. Note that the Main Power LED will turn on when the Main Board Switch is thrown.
3. Next use a **pointed object** to turn the Sleep Mode Dipswitch to the 'ON' position.
 - You will notice that the Sleep Mode LED will light up once the Sleep Mode Dip Switch is turned to the "ON" position. This means that the device will have X, Y, and Z outputs on the output pads. Sleep mode will actually be disabled and the device is now active.
 - When "OFF", no output voltages should be seen, and the LED will be off. This will mean the board is in Sleep Mode, in low power consumption.
4. Start to measure the voltages on the X, Y, and Z axes. Solder these pads to your microcontroller A/D terminals or other measuring devices.

The evaluation board has pads for interfacing to a 3.3 V power source or battery. The pads on the side of the board also provide a means for connecting to the accelerometer analog output by soldering a wire from the evaluation board to another breadboard or system. The ON/OFF switch provides power to the accelerometer and helps preserve battery life if a battery is being used as the power source. **S1** must be set towards the ON position for the accelerometer to function. The green LED labeled *PWR* is lit when power is supplied to the accelerometer.

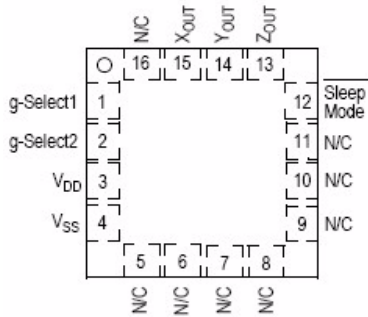

Figure 2. Pin Connections for MMA7260QT and MMA7261QT

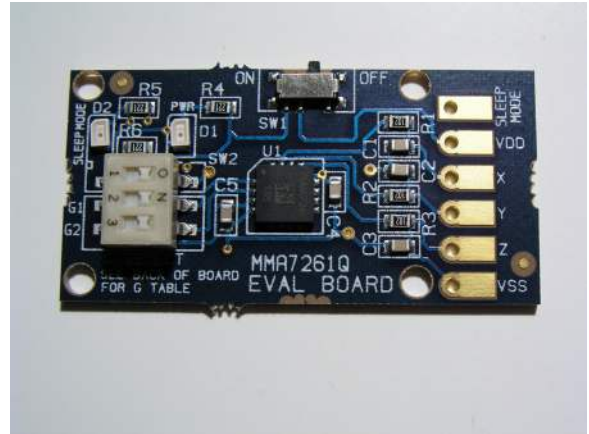

Figure 3. Photo of MMA7261QT Evaluation Board (similar to MMA7260QT Evaluation Board)

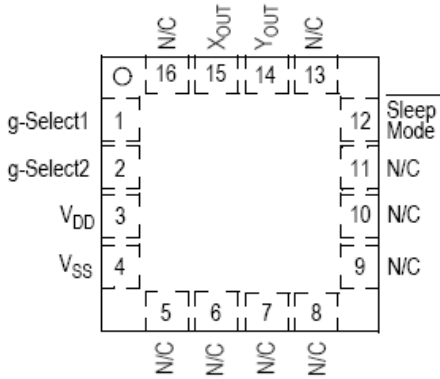

Figure 4. Pin Connections for MMA6270QT and MMA6271QT

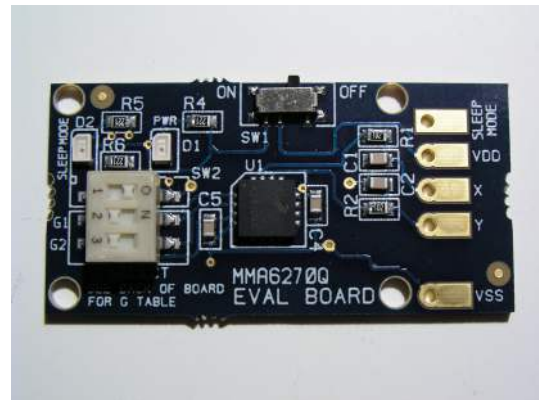

Figure 5. Photo of MMA6270QT Evaluation Board (similar to MMA6271QT Evaluation Board)

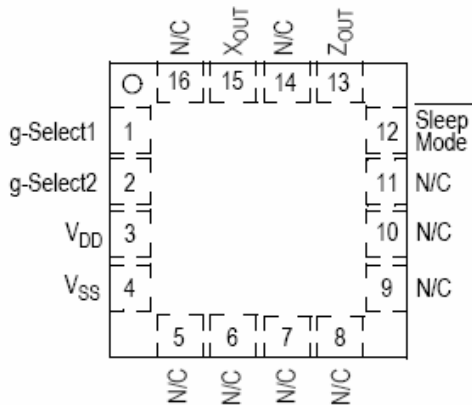

Figure 6. Pin Connections for the MMA6280QT and MMA6281QT

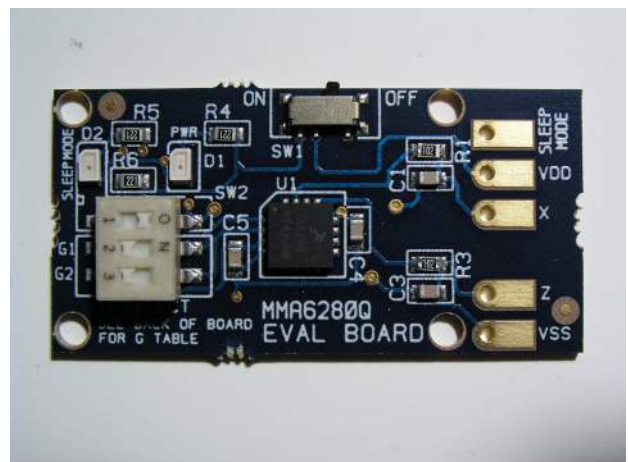

Figure 7. Photo of MMA6280QT Evaluation Board (similar to MMA6281QT Evaluation Board)

APPENDIX 2

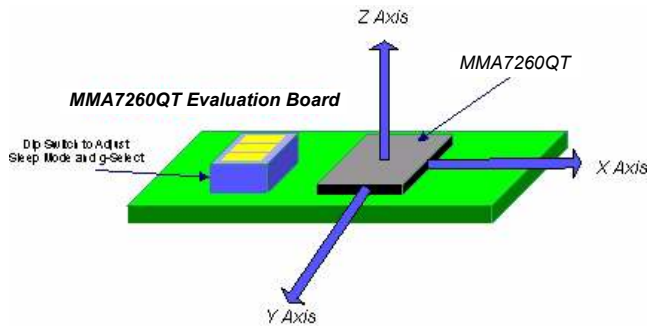

Figure 8. Board Orientation Corresponding for the Three Axes of the MMA7260QT and MMA7261QT

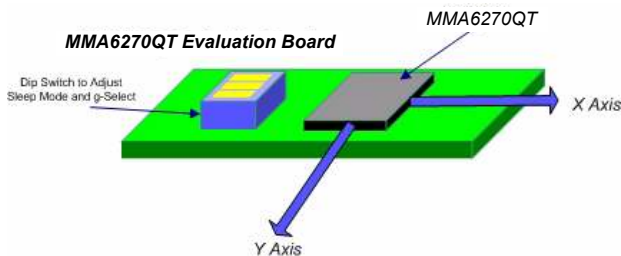

Figure 9. Board Orientation for the MMA6270QT and MMA6271QT

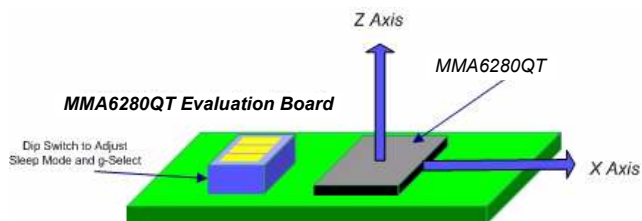

Figure 10. Board Orientation for the MMA6280QT and MMA6281QT

APPENDIX 3

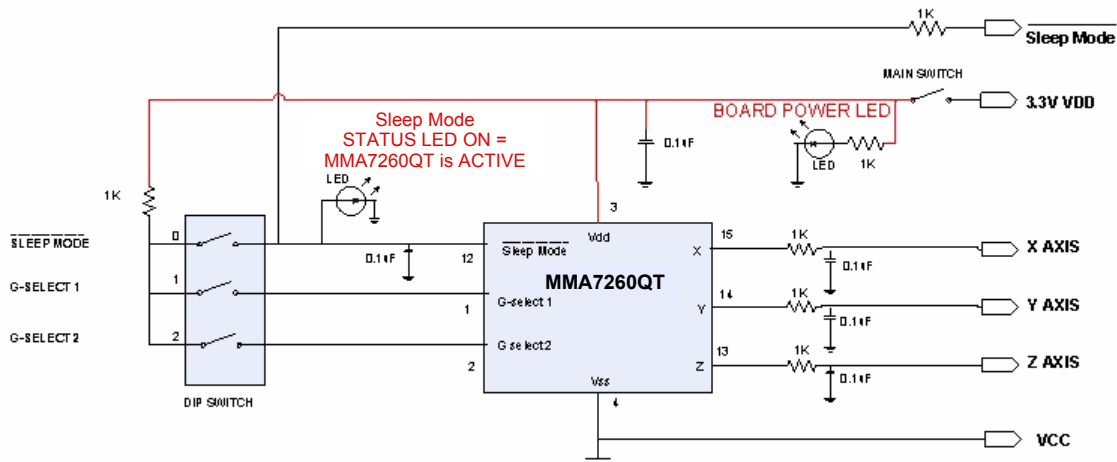

Figure 11. Circuit Schematic of the MMA7260QT or MMA7261QT Evaluation Board

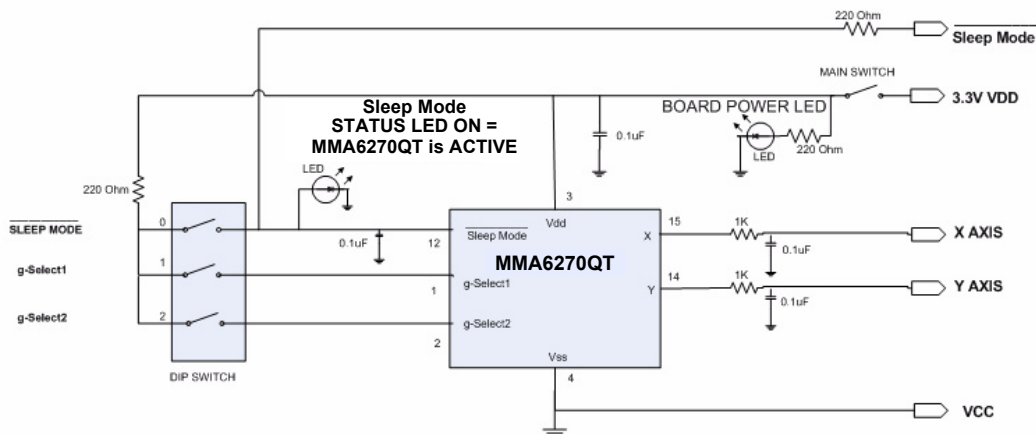

Figure 12. Circuit Schematic of the MMA6270QT or MMA6271QT Evaluation Board

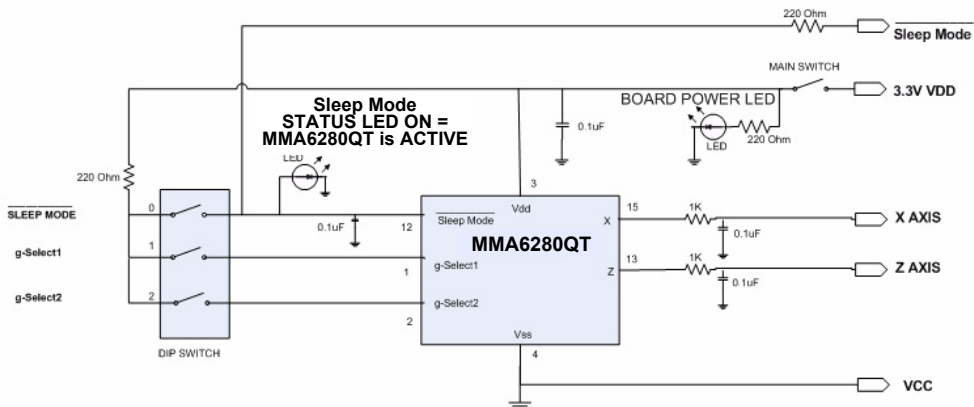

Figure 13. Circuit Schematic of the MMA6280QT or MMA6281QT Evaluation Board

Table 3. Description of Output/Input Pads

Output/Input Pads	Description
Sleep Mode	Used for an external source to enable/disable Sleep Mode
3.3 V V_{DD}	Input voltage V_{DD} for Power Supply
X axis	Analog Voltage output of X axis
Y axis	Analog Voltage output of Y axis
YZ axis	Analog Voltage output of YZ axis
Z axis	Analog Voltage output of Z axis
V_{SS}	Ground Pin for Power Supply

APPENDIX 4

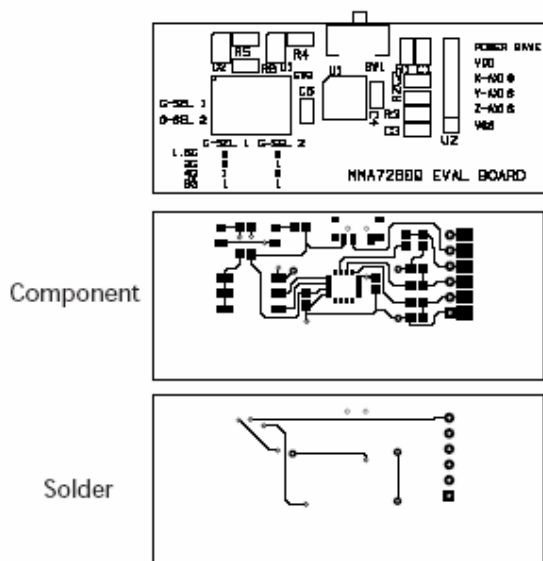

Figure 14. MMA7260QT Board Layout for Component, Top Layer, and Bottom Layer

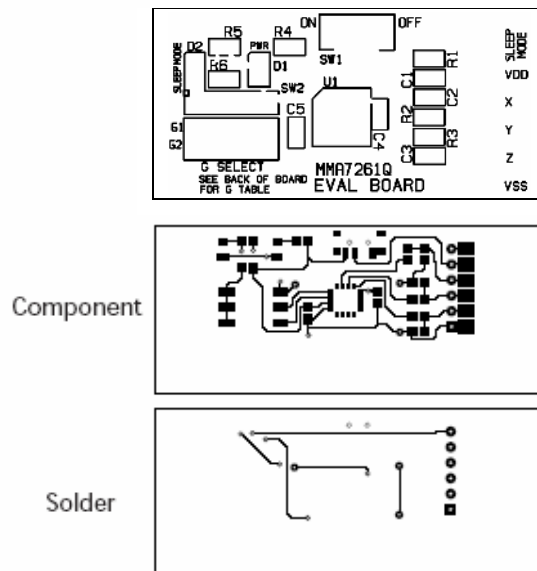

Figure 15. MMA7261QT Board Layout for Component, Top Layer, and Bottom Layer

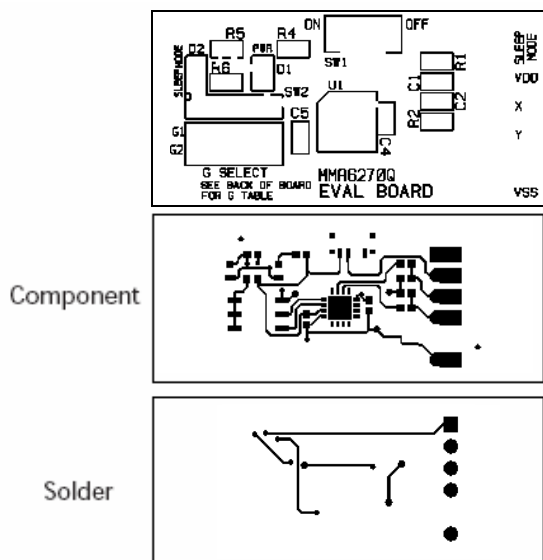

Figure 16. MMA6270QT Board Layout for Component, Top Layer, and Bottom Layer

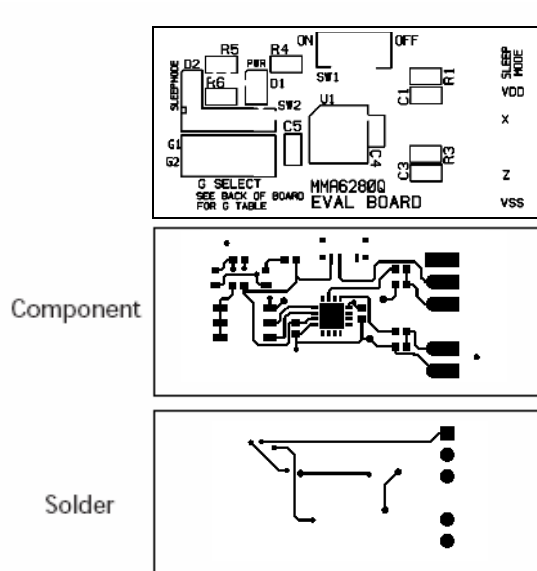

Figure 17. MMA6280QT Board Layout for Component, Top Layer, and Bottom Layer

APPENDIX 5

STATIC ACCELERATION

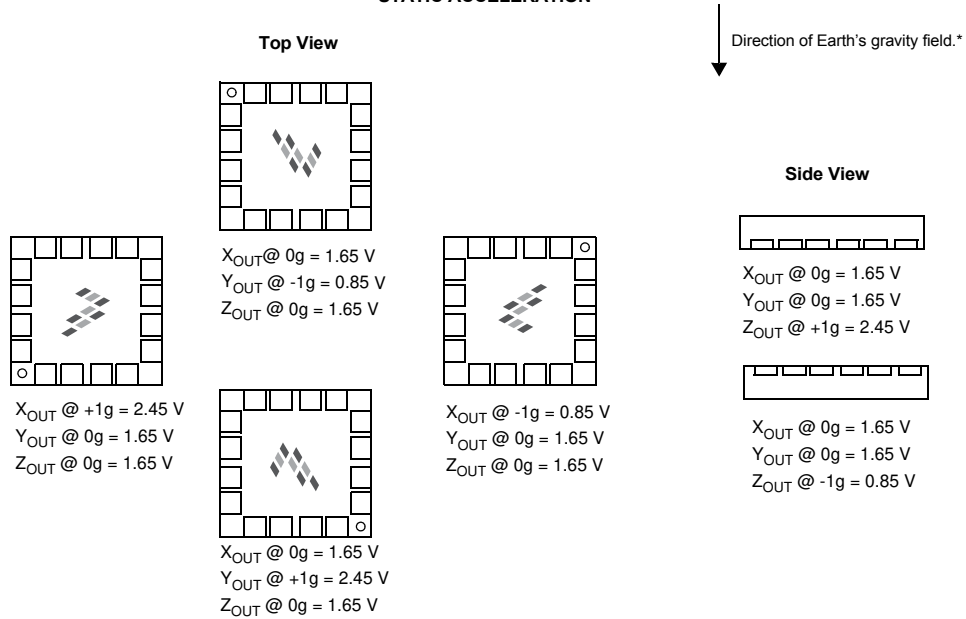

Figure 18. Orientation and Output Values for MMA7260QT, MMA6270QT and MMA6280QT

STATIC ACCELERATION

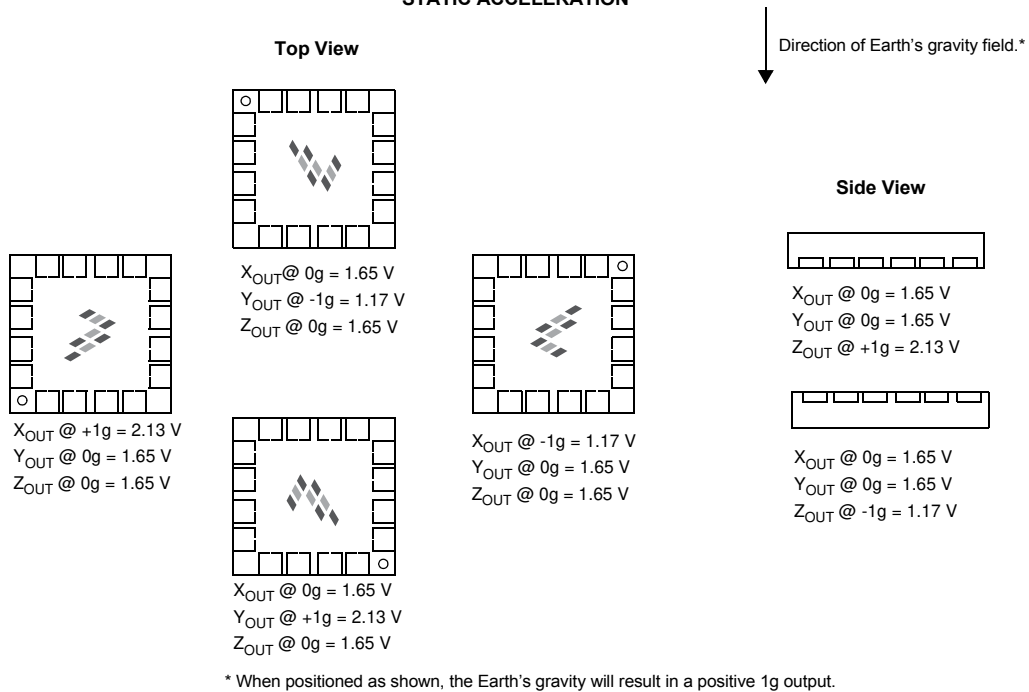

Figure 19. Orientation and Output Values for MMA7261QT



How to Reach Us:

Home Page:

www.freescale.com

E-mail:

support@freescale.com

USA/Europe or Locations Not Listed:

Freescale Semiconductor
Technical Information Center, CH370
1300 N. Alma School Road
Chandler, Arizona 85224
+1-800-521-6274 or +1-480-768-2130
support@freescale.com

Europe, Middle East, and Africa:

Freescale Halbleiter Deutschland GmbH
Technical Information Center
Schatzbogen 7
81829 Muenchen, Germany
+44 1296 380 456 (English)
+46 8 52200080 (English)
+49 89 92103 559 (German)
+33 1 69 35 48 48 (French)
support@freescale.com

Japan:

Freescale Semiconductor Japan Ltd.
Headquarters
ARCO Tower 15F
1-8-1, Shimo-Meguro, Meguro-ku,
Tokyo 153-0064
Japan
0120 191014 or +81 3 5437 9125
support.japan@freescale.com

Asia/Pacific:

Freescale Semiconductor Hong Kong Ltd.
Technical Information Center
2 Dai King Street
Tai Po Industrial Estate
Tai Po, N.T., Hong Kong
+800 2666 8080
support.asia@freescale.com

For Literature Requests Only:

Freescale Semiconductor Literature Distribution Center
P.O. Box 5405
Denver, Colorado 80217
1-800-441-2447 or 303-675-2140
Fax: 303-675-2150
LDCForFreescaleSemiconductor@hibbertgroup.com

Information in this document is provided solely to enable system and software implementers to use Freescale Semiconductor products. There are no express or implied copyright licenses granted hereunder to design or fabricate any integrated circuits or integrated circuits based on the information in this document.

Freescale Semiconductor reserves the right to make changes without further notice to any products herein. Freescale Semiconductor makes no warranty, representation or guarantee regarding the suitability of its products for any particular purpose, nor does Freescale Semiconductor assume any liability arising out of the application or use of any product or circuit, and specifically disclaims any and all liability, including without limitation consequential or incidental damages. "Typical" parameters that may be provided in Freescale Semiconductor data sheets and/or specifications can and do vary in different applications and actual performance may vary over time. All operating parameters, including "Typicals", must be validated for each customer application by customer's technical experts. Freescale Semiconductor does not convey any license under its patent rights nor the rights of others. Freescale Semiconductor products are not designed, intended, or authorized for use as components in systems intended for surgical implant into the body, or other applications intended to support or sustain life, or for any other application in which the failure of the Freescale Semiconductor product could create a situation where personal injury or death may occur. Should Buyer purchase or use Freescale Semiconductor products for any such unintended or unauthorized application, Buyer shall indemnify and hold Freescale Semiconductor and its officers, employees, subsidiaries, affiliates, and distributors harmless against all claims, costs, damages, and expenses, and reasonable attorney fees arising out of, directly or indirectly, any claim of personal injury or death associated with such unintended or unauthorized use, even if such claim alleges that Freescale Semiconductor was negligent regarding the design or manufacture of the part.

Freescale™ and the Freescale logo are trademarks of Freescale Semiconductor, Inc. All other product or service names are the property of their respective owners.

© Freescale Semiconductor, Inc. 2006. All rights reserved.

