

National Semiconductor is now part of  
Texas Instruments.

Search <http://www.ti.com/> for the latest technical  
information and details on our current products and services.

## Digital Temperature Sensor and Thermal Watchdog with Two-Wire Interface

### General Description

The LM75B and LM75C are industry-standard digital temperature sensors with an integrated Sigma-Delta analog-to-digital converter and I<sup>2</sup>C® interface. The LM75 provides 9-bit digital temperature readings with an accuracy of ±2°C from -25°C to 100°C and ±3°C over -55°C to 125°C.

Communication is accomplished over a 2-wire interface which operates up to 400kHz. The LM75 has three address pins, allowing up to eight LM75 devices to operate on the same 2-wire bus. The LM75 has a dedicated over-temperature output (O.S.) with programmable limit and hysteresis. This output has programmable fault tolerance, which allows the user to define the number of consecutive error conditions that must occur before O.S. is activated.

The wide temperature and supply range and I<sup>2</sup>C interface make the LM75 ideal for a number of applications including base stations, electronic test equipment, office electronics, personal computers, and any other system where thermal management is critical to performance. The LM75B and LM75C are available in an SOP-8 package or MSOP-8 package.

### Applications

- General System Thermal Management
- Communications Infrastructure
- Electronic Test Equipment
- Environmental Monitoring

### Features

- No external components required
- Shutdown mode to minimize power consumption
- Up to eight LM75s can be connected to a single bus
- Power up defaults permit stand-alone operation as thermostat
- UL Recognized Component (LM75B and LM75C)

### Key Specifications

■ Supply Voltage	LM75B, LM75C	3.0V to 5.5V
■ Supply Current	operating	280 µA (typ)
	shutdown	4 µA (typ)
■ Temperature Accuracy	-25°C to 100°C	±2°C (max)
	-55°C to 125°C	±3°C (max)

### Simplified Block Diagram

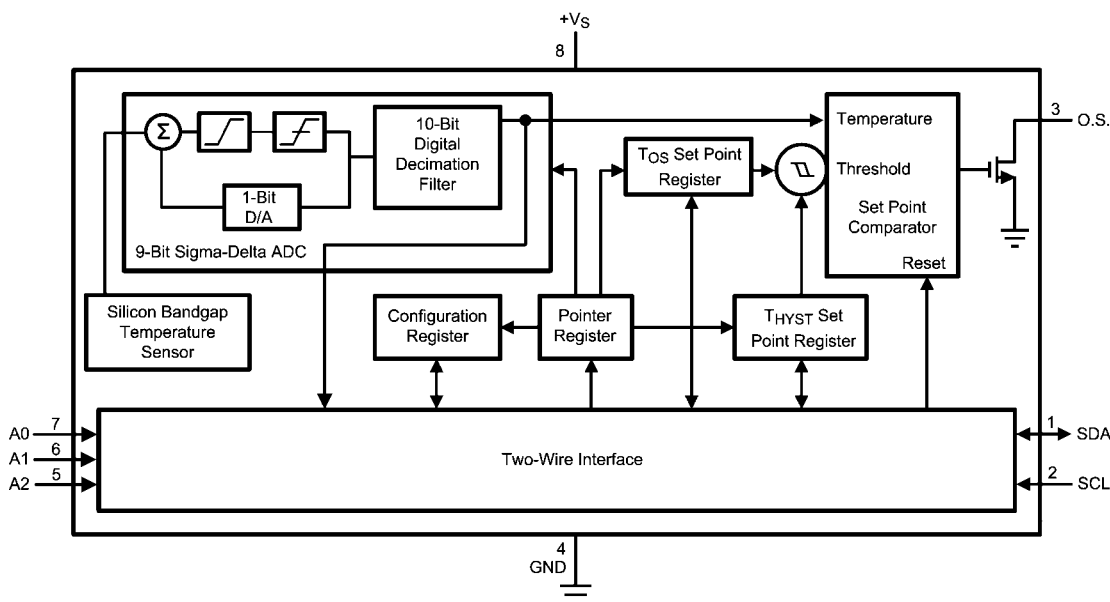

30099801

I<sup>2</sup>C® is a registered trademark of Philips Corporation.

## Connection Diagram

LM75B, LM75C SOP-8 and Mini MSOP-8

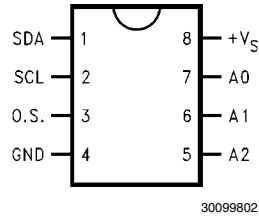

## Pin Descriptions

Label	Pin #	Function	Typical Connection
SDA	1	I <sup>2</sup> C Serial Bi-Directional Data Line. Open Drain.	From Controller, tied to a pull-up resistor or current source
SCL	2	I <sup>2</sup> C Clock Input	From Controller, tied to a pull-up resistor or current source
O.S.	3	Overtemperature Shutdown. Open Drain Output	Pull-up Resistor, Controller Interrupt Line
GND	4	Power Supply Ground	Ground
+V <sub>S</sub>	8	Positive Supply Voltage Input	DC Voltage from 3V to 5.5V; 100 nF bypass capacitor with 10 μF bulk capacitance in the near vicinity
A0–A2	7,6,5	User-Set I <sup>2</sup> C Address Inputs	Ground (Low, “0”) or +V <sub>S</sub> (High, “1”)

## Typical Application

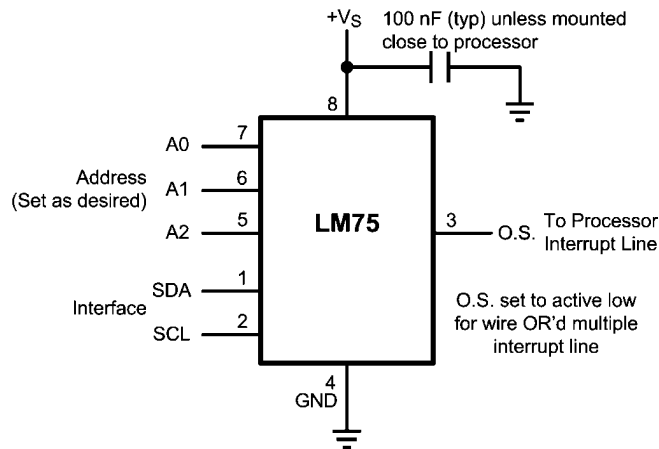

FIGURE 1. Typical Application

## Ordering Information

Order Number	Package Marking	NS Package Number	Supply Voltage	Transport Media	Noise Filter on SDA and SCL
LM75BIM-3	LM75BIM-3	M08A (SOP-8)	3.3V	95 Units in Rail	Yes
LM75BIMX-3	LM75BIM-3	M08A (SOP-8)	3.3V	2500 Units on Tape and Reel	Yes
LM75BIMM-3	T01B	MUA08A (MSOP-8)	3.3V	1000 Units on Tape and Reel	Yes
LM75BIMMX-3	T01B	MUA08A (MSOP-8)	3.3V	3500 Units on Tape and Reel	Yes
LM75BIM-5	LM75BIM-5	M08A (SOP-8)	5V	95 Units in Rail	Yes
LM75BIMX-5	LM75BIM-5	M08A (SOP-8)	5V	2500 Units on Tape and Reel	Yes
LM75BIMM-5	T00B	MUA08A (MSOP-8)	5V	1000 Units on Tape and Reel	Yes
LM75BIMMX-5	T00B	MUA08A (MSOP-8)	5V	3500 Units on Tape and Reel	Yes
LM75CIM-3	LM75CIM-3	M08A (SOP-8)	3.3V	95 Units in Rail	Not Available
LM75CIMX-3	LM75CIM-3	M08A (SOP-8)	3.3V	2500 Units on Tape and Reel	Not Available
LM75CIMM-3	T01C	MUA08A (MSOP-8)	3.3V	1000 Units on Tape and Reel	Not Available
LM75CIMMX-3	T01C	MUA08A (MSOP-8)	3.3V	3500 Units on Tape and Reel	Not Available
LM75CIM-5	LM75CIM-5	M08A (SOP-8)	5V	95 Units in Rail	Not Available
LM75CIMX-5	LM75CIM-5	M08A (SOP-8)	5V	2500 Units on Tape and Reel	Not Available
LM75CIMM-5	T00C	MUA08A (MSOP-8)	5V	1000 Units on Tape and Reel	Not Available
LM75CIMMX-5	T00C	MUA08A (MSOP-8)	5V	3500 Units on Tape and Reel	Not Available

## Absolute Maximum Ratings *(Note 1)*

Supply Voltage Pin (+V <sub>S</sub> )	-0.3V to 6.5V
Voltage at A0, A1 and A2 Pins	-0.3V to (+V <sub>S</sub> + 0.3V) and must be ≤ 6.5V
Voltage at OS, SCL and SDA Pins	-0.3V to 6.5V
Input Current at any Pin <i>(Note 2)</i>	5 mA
Package Input Current <i>(Note 2)</i>	20 mA
Storage Temperature	-65°C to +150°C
ESD Susceptibility <i>(Note 4)</i>	LM75B LM75C
Human Body Model	2500V 1500V
Machine Model	250V 100V
O.S. Output Sink Current	10 mA
O.S. Output Voltage	6.5V

## Operating Ratings

Specified Temperature Range <i>(Note 5)</i>	T <sub>MIN</sub> to T <sub>MAX</sub> -55°C to +125°C
Supply Voltage Range (+V <sub>S</sub> ) LM75B, LM75C	+3.0V to +5.5V
<i>Soldering process must comply with National Semiconductor's Reflow Temperature Profile specifications. Refer to <a href="http://www.national.com/packaging">www.national.com/packaging</a>. <i>(Note 3)</i></i>	

## Temperature-to-Digital Converter Characteristics

Unless otherwise noted, these specifications apply for: +V<sub>S</sub> = +5 Vdc for LM75BIM-5, LM75BIMM-5, LM75CIM-5, and LM75CIMM-5; and +V<sub>S</sub> = +3.3 Vdc for LM75BIM-3, LM75BIMM-3, LM75CIM-3, and LM75CIMM-3 *(Note 6)*. **Boldface limits apply for T<sub>A</sub> = T<sub>J</sub> = T<sub>MIN</sub> to T<sub>MAX</sub>**; all other limits T<sub>A</sub> = T<sub>J</sub> = +25°C, unless otherwise noted.

Parameter	Conditions	Typical <i>(Note 12)</i>	Limits <i>(Note 7)</i>	Units <b>(Limit)</b>	
Accuracy	T <sub>A</sub> = -25°C to +100°C		<b>±2.0</b>	°C (max)	
	T <sub>A</sub> = -55°C to +125°C		<b>±3.0</b>		
Resolution		9		Bits	
Temperature Conversion Time	<i>(Note 8)</i>	100	<b>300</b>	ms (max)	
Quiescent Current	LM75B	I <sup>2</sup> C Inactive	0.25	<b>0.5</b>	mA (max)
		Shutdown Mode, +V <sub>S</sub> = 3V	4		μA
		Shutdown Mode, +V <sub>S</sub> = 5V	6		μA
	LM75C	I <sup>2</sup> C Inactive	0.25	<b>1.0</b>	mA (max)
		Shutdown Mode, +V <sub>S</sub> = 3V	4		μA
		Shutdown Mode, +V <sub>S</sub> = 5V	6		μA
O.S. Output Saturation Voltage	I <sub>OUT</sub> = 4.0 mA		<b>0.8</b>	V (max)	
O.S. Delay	<i>(Note 10)</i>		<b>1</b>	Conversion (min)	
			<b>6</b>	Conversions (max)	
T <sub>OS</sub> Default Temperature	<i>(Note 11)</i>	80		°C	
T <sub>HYST</sub> Default Temperature	<i>(Note 11)</i>	75		°C	

## Logic Electrical Characteristics

### DIGITAL DC CHARACTERISTICS

Unless otherwise noted, these specifications apply for  $+V_S = +5$  Vdc for LM75BIM-5, LM75BIMM-5, LM75CIM-5, and LM75CIMM-5; and  $+V_S = +3.3$  Vdc for LM75BIM-3, LM75BIMM-3, LM75CIM-3, and LM75CIMM-3 (Note 6). **Boldface limits apply for  $T_A = T_J = T_{MIN}$  to  $T_{MAX}$** ; all other limits  $T_A = T_J = +25^\circ\text{C}$ , unless otherwise noted.

Symbol	Parameter	Conditions	Typical (Note 12)	Limits (Note 7)	Units (Limit)
$V_{IN(1)}$	Logical "1" Input Voltage			$+V_S \times 0.7$	V (min)
				$+V_S + 0.3$	V (max)
$V_{IN(0)}$	Logical "0" Input Voltage			$-0.3$	V (min)
				$+V_S \times 0.3$	V (max)
$I_{IN(1)}$	Logical "1" Input Current	$V_{IN} = +V_S$	0.005	<b>1.0</b>	$\mu\text{A}$ (max)
$I_{IN(0)}$	Logical "0" Input Current	$V_{IN} = 0\text{V}$	-0.005	<b>-1.0</b>	$\mu\text{A}$ (max)
$C_{IN}$	All Digital Inputs		5		pF
$I_{OH}$	High Level Output Current	LM75B	$V_{OH} = 5\text{V}$	<b>10</b>	$\mu\text{A}$ (max)
		LM75C	$V_{OH} = 5\text{V}$	<b>100</b>	$\mu\text{A}$ (max)
$V_{OL}$	Low Level Output Voltage	$I_{OL} = 3\text{ mA}$		<b>0.4</b>	V (max)
$t_{OF}$	Output Fall Time	$C_L = 400\text{ pF}$ $I_O = 3\text{ mA}$		<b>250</b>	ns (max)

### I<sup>2</sup>C DIGITAL SWITCHING CHARACTERISTICS

Unless otherwise noted, these specifications apply for  $V_S = +5$  Vdc for LM75BIM-5, LM75BIMM-5, LM75CIM-5, and LM75CIMM-5; and  $+V_S = +3.3$  Vdc for LM75BIM-3, LM75BIMM-3, LM75CIM-3, and LM75CIMM-3.  $C_L$  (load capacitance) on output lines = 80 pF unless otherwise specified. **Boldface limits apply for  $T_A = T_J = T_{MIN}$  to  $T_{MAX}$** ; all other limits  $T_A = T_J = +25^\circ\text{C}$ , unless otherwise noted.

Symbol	Parameter	Conditions	Typical (Note 12)	Limits (Note 7, Note 14)	Units (Limit)
$t_1$	SCL (Clock) Period			<b>2.5</b>	$\mu\text{s}$ (min)
$t_2$	Data in Set-Up Time to SCL High			<b>100</b>	ns (min)
$t_3$	Data Out Stable after SCL Low			<b>0</b>	ns (min)
$t_4$	SDA Low Set-Up Time to SCL Low (Start Condition)			<b>100</b>	ns (min)
$t_5$	SDA High Hold Time after SCL High (Stop Condition)			<b>100</b>	ns (min)
$t_{TIMEOUT}$	SDA Time Low for Reset of Serial Interface (Note 13)	LM75B		<b>75</b>	ms (min)
		LM75C		<b>325</b>	ms (max)
				Not Applicable	

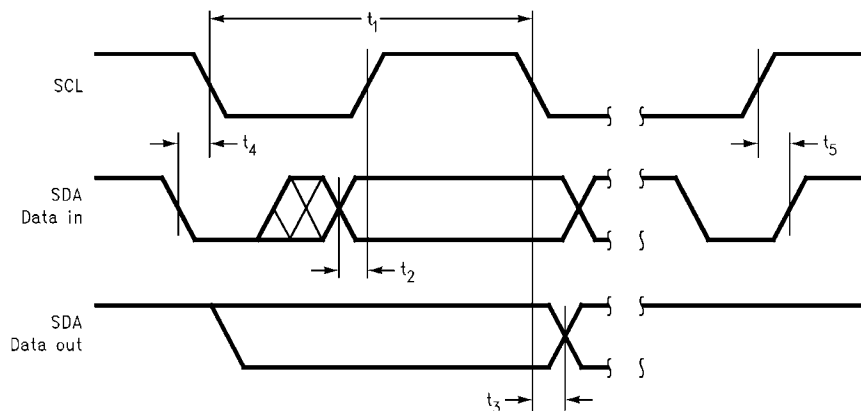

30099804

**Note 1:** Absolute Maximum Ratings indicate limits beyond which damage to the device may occur. DC and AC electrical specifications do not apply when operating the device beyond its rated operating conditions.

**Note 2:** When the input voltage ( $V_I$ ) at any pin exceeds the power supplies ( $V_I < GND$  or  $V_I > +V_S$ ) the current at that pin should be limited to 5 mA. The 20 mA maximum package input current rating limits the number of pins that can safely exceed the power supplies with an input current of 5 mA to four.

**Note 3:** Reflow temperature profiles are different for lead-free and non-lead-free packages.

**Note 4:** Human body model, 100 pF discharged through a 1.5 kΩ resistor. Machine model, 200 pF discharged directly into each pin. The Charged Device Model (CDM) is a specified circuit characterizing an ESD event that occurs when a device acquires charge through some triboelectric (frictional) or electrostatic induction processes and then abruptly touches a grounded object or surface.

**Note 5:** LM75  $\theta_{JA}$  (thermal resistance, junction-to-ambient) when attached to a printed circuit board with 2 oz. foil similar to the one shown in [Figure 3](#) is summarized in the table below:

Device Number	NS Package Number	Thermal Resistance ( $\theta_{JA}$ )
LM75BIM-3, LM75BIM-5, LM75CIM-3, LM75CIM-5	M08A	200°C/W
LM75BIMM-3, LM75BIMM-5, LM75CIMM-3, LM75CIMM-5	MUA08A	250°C/W

**Note 6:** All part numbers of the LM75 will operate properly over the  $+V_S$  supply voltage range of 3V to 5.5V. The devices are tested and specified for rated accuracy at their nominal supply voltage. Accuracy will typically degrade 1°C/V of variation in  $+V_S$  as it varies from the nominal value.

**Note 7:** Limits are guaranteed to National's AOQL (Average Outgoing Quality Level).

**Note 8:** The conversion-time specification is provided to indicate how often the temperature data is updated. The LM75 can be accessed at any time and reading the Temperature Register will yield result from the last temperature conversion. When the LM75 is accessed, the conversion that is in process will be interrupted and it will be restarted after the end of the communication. Accessing the LM75 continuously without waiting at least one conversion time between communications will prevent the device from updating the Temperature Register with a new temperature conversion result. Consequently, the LM75 should not be accessed continuously with a wait time of less than 300 ms.

**Note 9:** For best accuracy, minimize output loading. Higher sink currents can affect sensor accuracy with internal heating. This can cause an error of 0.64°C at full rated sink current and saturation voltage based on junction-to-ambient thermal resistance.

**Note 10:** O.S. Delay is user programmable up to 6 "over limit" conversions before O.S. is set to minimize false tripping in noisy environments.

**Note 11:** Default values set at power up.

**Note 12:** Typicals are at  $T_A = 25^\circ\text{C}$  and represent most likely parametric norm.

**Note 13:** Holding the SDA line low for a time greater than  $t_{\text{TIMEOUT}}$  will cause the LM75B to reset SDA to the IDLE state of the serial bus communication (SDA set High).

**Note 14:** Timing specifications are tested at the bus input logic levels ( $V_{in(0)}=0.3 \times V_A$  for a falling edge and  $V_{in(1)}=0.7 \times V_A$  for a rising edge) when the SCL and SDA edge rates are similar.

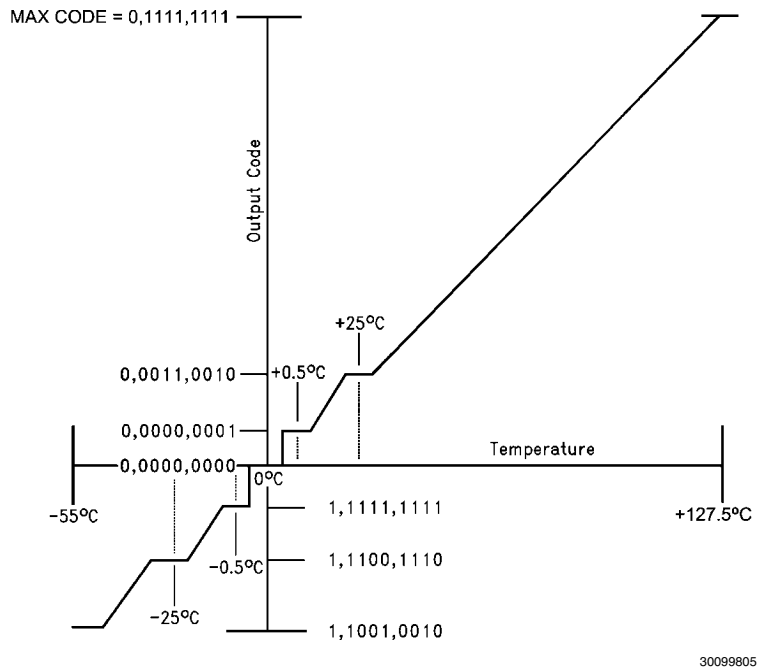

**FIGURE 2. Temperature-to-Digital Transfer Function (Non-linear scale for clarity)**

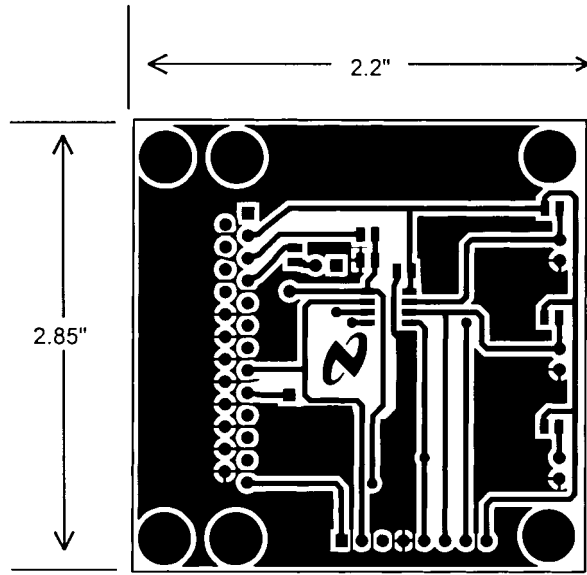

30099806

**FIGURE 3. Printed Circuit Board Used for Thermal Resistance Specifications**



## Typical Performance Characteristics

Static Quiescent Current vs Temperature (LM75C)

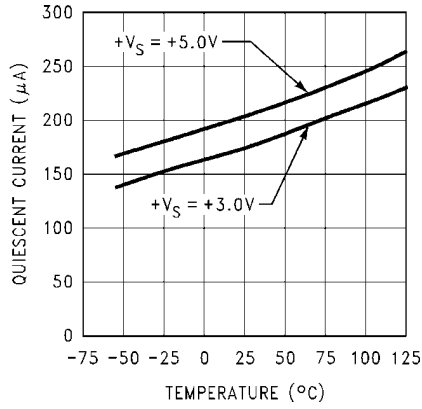

30099816

Dynamic Quiescent Current vs Temperature (LM75C)

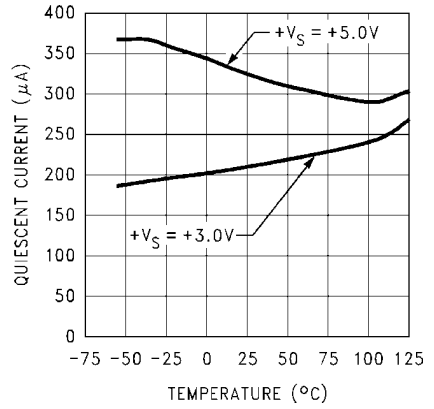

30099817

Accuracy vs Temperature (LM75C)

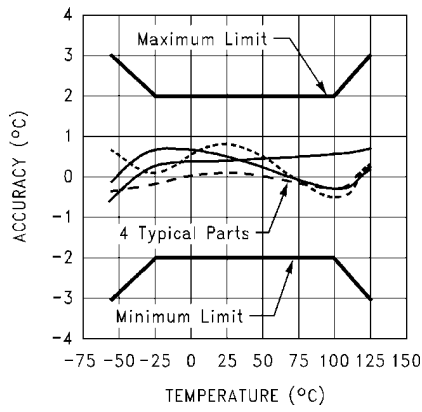

30099818

## 1.0 Functional Description

The LM75 temperature sensor incorporates a band-gap type temperature sensor and 9-bit ADC (Sigma-Delta Analog-to-Digital Converter). The temperature data output of the LM75 is available at all times via the I<sup>2</sup>C bus. If a conversion is in progress, it will be stopped and restarted after the read. A digital comparator is also incorporated that compares a series of readings, the number of which is user-selectable, to user-programmable setpoint and hysteresis values. The comparator trips the O.S. output line, which is programmable for mode and polarity.

The LM75B contains all the functionality of the LM75C, plus two additional features:

1. The LM75B has an integrated low-pass filter on both the SDA and the SCL line. These filters increase communications reliability in noisy environments.
2. The LM75B also has a bus fault timeout feature. If the SDA line is held low for longer than  $t_{\text{TIMEOUT}}$  (see specification) the LM75B will reset to the IDLE state (SDA set to high impedance) and wait for a new start condition. The TIMEOUT feature is not functional in Shutdown Mode.

### 1.1 O.S. OUTPUT, $T_{\text{OS}}$ AND $T_{\text{HYST}}$ LIMITS

In Comparator mode the O.S. Output behaves like a thermostat. The output becomes active when temperature exceeds the  $T_{\text{OS}}$  limit, and leaves the active state when the temperature drops below the  $T_{\text{HYST}}$  limit. In this mode the O.S. output can be used to turn a cooling fan on, initiate an emergency system shutdown, or reduce system clock speed. Shutdown mode does not reset O.S. state in a comparator mode.

In Interrupt mode exceeding  $T_{\text{OS}}$  also makes O.S. active but O.S. will remain active indefinitely until reset by reading any register via the I<sup>2</sup>C interface. Once O.S. has been activated by crossing  $T_{\text{OS}}$ , then reset, it can be activated again only by Temperature going below  $T_{\text{HYST}}$ . Again, it will remain active indefinitely until being reset by a read. Placing the LM75 in shutdown mode also resets the O.S. Output.

## 1.2 POWER UP AND POWER DOWN

The LM75 always powers up in a known state. The power up default conditions are:

1. Comparator mode
2.  $T_{\text{OS}} = 80^{\circ}\text{C}$
3.  $T_{\text{HYST}} = 75^{\circ}\text{C}$
4. O.S. active low
5. Pointer = "00"

When the supply voltage is less than about 1.7V, the LM75 is considered powered down. As the supply voltage rises above the nominal 1.7V power up threshold, the internal registers are reset to the power up default values listed above.

### 1.2.1 Stand-Alone Thermostat Mode

If the LM75 is *not connected* to the I<sup>2</sup>C bus on power up, it will act as a stand-alone thermostat with the power up default conditions listed above. It is optional, but recommended, to connect the address pins (A2, A1, A0) and the SCL and SDA pins together and to a 10k pull-up resistor to  $+V_{\text{S}}$  for better noise immunity. Any of these pins may also be tied high separately through a 10k pull-up resistor.

## 1.3 I<sup>2</sup>C BUS INTERFACE

The LM75 operates as a slave on the I<sup>2</sup>C bus, so the SCL line is an input (no clock is generated by the LM75) and the SDA line is a bi-directional serial data path. According to I<sup>2</sup>C bus specifications, the LM75 has a 7-bit slave address. The four most significant bits of the slave address are hard wired inside the LM75 and are "1001". The three least significant bits of the address are assigned to pins A2–A0, and are set by connecting these pins to ground for a low, (0); or to  $+V_{\text{S}}$  for a high, (1).

Therefore, the complete slave address is:

1	0	0	1	A2	A1	A0
MSB				LSB		

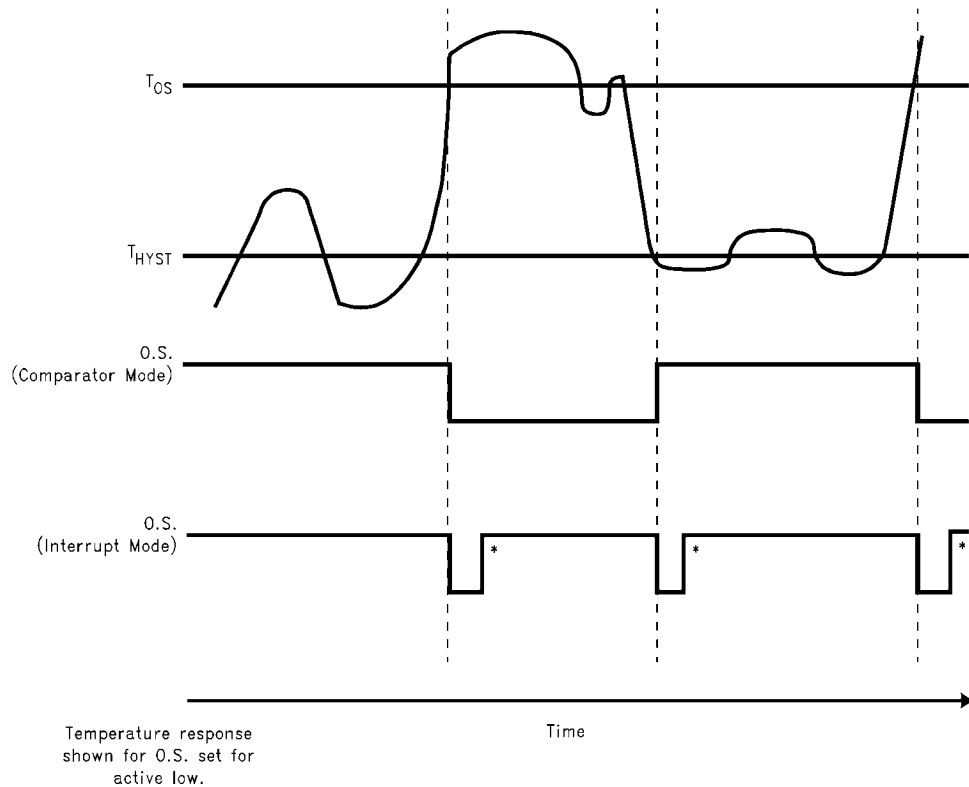

30099807

**Note 15:** These interrupt mode resets of O.S. occur only when LM75 is read or placed in shutdown. Otherwise, O.S. would remain active indefinitely for any event.

**FIGURE 4. O.S. Output Temperature Response Diagram**

#### 1.4 TEMPERATURE DATA FORMAT

Temperature data can be read from the Temperature,  $T_{OS}$  Set Point, and  $T_{HYST}$  Set Point registers; and written to the  $T_{OS}$  Set Point, and  $T_{HYST}$  Set Point registers. Temperature data is represented by a 9-bit, two's complement word with an LSB (Least Significant Bit) equal to  $0.5^{\circ}\text{C}$ :

Temperature	Digital Output	
	Binary	Hex
+125°C	0 1111 1010	0FAh
+25°C	0 0011 0010	032h
+0.5°C	0 0000 0001	001h
0°C	0 0000 0000	000h
-0.5°C	1 1111 1111	1FFh
-25°C	1 1100 1110	1CEh
-55°C	1 1001 0010	192h

#### 1.5 SHUTDOWN MODE

Shutdown mode is enabled by setting the shutdown bit in the Configuration register via the I<sup>2</sup>C bus. Shutdown mode reduces power supply current significantly. See specified quiescent current specification in the electrical tables. In Interrupt mode O.S. is reset if previously set and is undefined in Comparator mode during shutdown. The I<sup>2</sup>C interface remains active. Activity on the clock and data lines of the I<sup>2</sup>C bus may slightly increase shutdown mode quiescent current.  $T_{OS}$ ,  $T_{HYST}$ , and Configuration registers can be read from and written to in shutdown mode.

For the LM75B, the TIMEOUT feature is turned off in Shutdown Mode.

#### 1.6 FAULT QUEUE

A fault queue of up to 6 faults is provided to prevent false tripping of O.S. when the LM75 is used in noisy environments. The number of faults set in the queue must occur consecutively to set the O.S. output.

#### 1.7 COMPARATOR/INTERRUPT MODE

As indicated in the O.S. Output Temperature Response Diagram, *Figure 4*, the events that trigger O.S. are identical for either Comparator or Interrupt mode. The most important difference is that in Interrupt mode the O.S. will remain set indefinitely once it has been set. To reset O.S. while in Interrupt mode, perform a read from any register in the LM75.

#### 1.8 O.S. OUTPUT

The O.S. output is an open-drain output and does not have an internal pull-up. A "high" level will not be observed on this pin until pull-up current is provided from some external source, typically a pull-up resistor. Choice of resistor value depends on many system factors but, in general, the pull-up resistor should be as large as possible. This will minimize any errors due to internal heating of the LM75. The maximum resistance of the pull up, based on LM75 specification for High Level Output Current, to provide a 2V high level, is 30 k $\Omega$ .

### 1.9 O.S. POLARITY

The O.S. output can be programmed via the configuration register to be either active low (default mode), or active high. In active low mode the O.S. output goes low when triggered

exactly as shown on the O.S. Output Temperature Response Diagram, [Figure 4](#). Active high simply inverts the polarity of the O.S. output.

### 1.10 INTERNAL REGISTER STRUCTURE

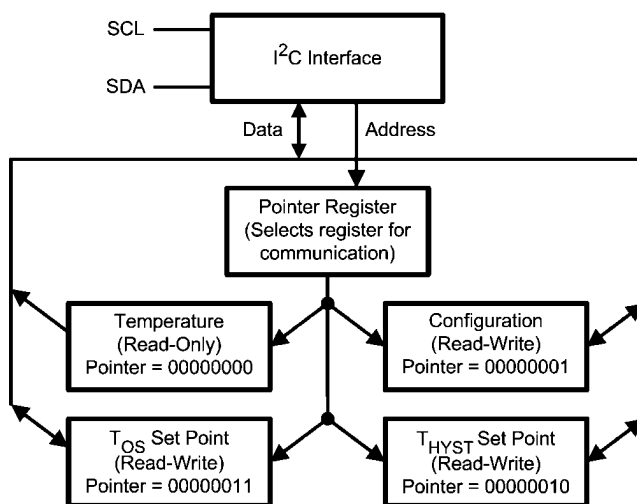

There are four data registers in the LM75B and LM75C selected by the Pointer register. At power-up the Pointer is set to "000"; the location for the Temperature Register. The Pointer register latches whatever the last location it was set to. In Interrupt Mode, a read from the LM75, or placing the device in shutdown mode, resets the O.S. output. All registers are read and write, except the Temperature register which is a read only.

A write to the LM75 will always include the address byte and the Pointer byte. A write to the Configuration register requires one data byte, and the  $T_{OS}$  and  $T_{HYST}$  registers require two data bytes.

Reading the LM75 can take place either of two ways: If the location latched in the Pointer is correct (most of the time it is expected that the Pointer will point to the Temperature register because it will be the data most frequently read from the LM75), then the read can simply consist of an address byte, followed by retrieving the corresponding number of data bytes. If the Pointer needs to be set, then an address byte,

pointer byte, repeat start, and another address byte will accomplish a read.

The first data byte is the most significant bit first, permitting only as much data as necessary to be read to determine temperature condition. For instance, if the first four bits of the temperature data indicates an overtemperature condition, the host processor could immediately take action to remedy the excessive temperatures. At the end of a read, the LM75 can accept either Acknowledge or No Acknowledge from the Master (No Acknowledge is typically used as a signal for the slave that the Master has read its last byte).

An inadvertent 8-bit read from a 16-bit register, with the D7 bit low, can cause the LM75 to stop in a state where the SDA line is held low as shown in [Figure 5](#). This can prevent any further bus communication until at least 9 additional clock cycles have occurred. Alternatively, the master can issue clock cycles until SDA goes high, at which time issuing a "Stop" condition will reset the LM75.

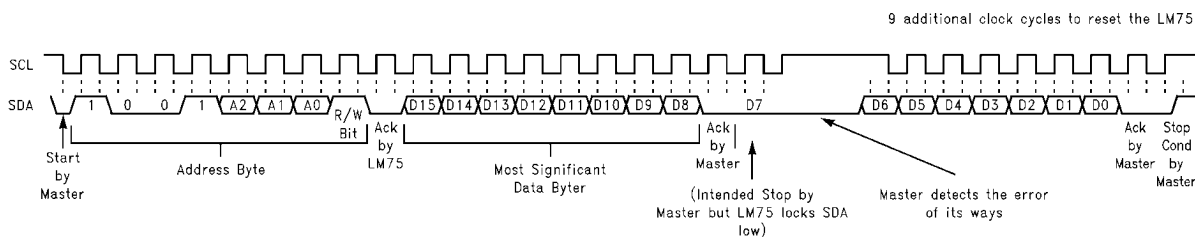

FIGURE 5. Inadvertent 8-Bit Read from 16-Bit Register where D7 is Zero ("0")

### 1.11 POINTER REGISTER (Selects which registers will be read from or written to):

P7	P6	P5	P4	P3	P2	P1	P0
0	0	0	0	0	Register Select		

P0-P1: Register Select:

P2	P1	P0	Register
0	0	0	Temperature (Read only) (Power-up default)
0	0	1	Configuration (Read/Write)
0	1	0	T <sub>HYST</sub> (Read/Write)
0	1	1	T <sub>OS</sub> (Read/Write)

P3-P7: Must be kept zero.

### 1.12 TEMPERATURE REGISTER (Read Only):

D15	D14	D13	D12	D11	D10	D9	D8	D7	D6	D5	D4	D3	D2	D1	D0
MSB	Bit 7	Bit 6	Bit 5	Bit 4	Bit 3	Bit 2	Bit 1	LSB	X	X	X	X	X	X	X

D0-D6: Undefined. D7-D15: Temperature Data. One LSB = 0.5°C. Two's complement format.

### 1.13 CONFIGURATION REGISTER (Read/Write):

D7	D6	D5	D4	D3	D2	D1	D0
0	0	0	Fault Queue		O.S. Polarity	Cmp/Int	Shutdown

Power up default is with all bits "0" (zero).

D0: Shutdown: When set to 1 the LM75 goes to low power shutdown mode.

D1: Comparator/Interrupt mode: 0 is Comparator mode, 1 is Interrupt mode.

D2: O.S. Polarity: 0 is active low, 1 is active high. O.S. is an open-drain output under all conditions.

D3-D4: Fault Queue: Number of faults necessary to detect before setting O.S. output to avoid false tripping due to noise. Faults are determined at the end of a conversion. See specified temperature conversion time in the electrical tables.

D4	D3	Number of Faults
0	0	1 (Power-up default)
0	1	2
1	0	4
1	1	6

D5-D7: These bits are used for production testing and must be kept zero for normal operation.

### 1.14 T<sub>HYST</sub> AND T<sub>OS</sub> REGISTER (Read/Write):

D15	D14	D13	D12	D11	D10	D9	D8	D7	D6	D5	D4	D3	D2	D1	D0
MSB	Bit 7	Bit 6	Bit 5	Bit 4	Bit 3	Bit 2	Bit 1	LSB	X	X	X	X	X	X	X

D0-D6: Undefined D7-D15: T<sub>HYST</sub> Or T<sub>OS</sub> Trip Temperature Data. Power up default is T<sub>OS</sub> = 80°C, T<sub>HYST</sub> = 75°C

## 2.0 I<sup>2</sup>C Timing Diagrams

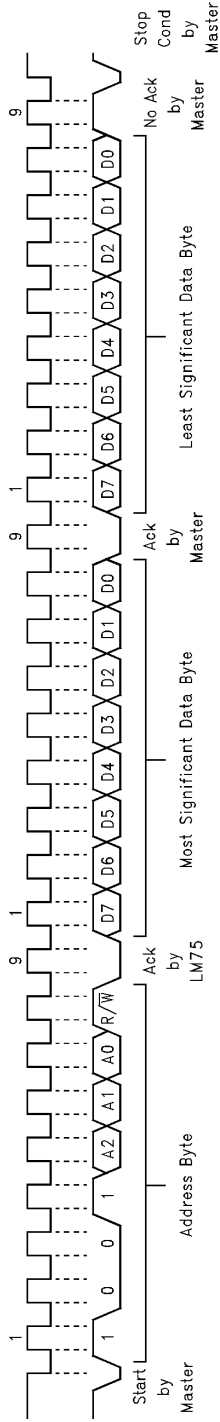

(a) Typical 2-Byte Read From Preset Pointer Location Such as Temp,  $T_{OS}$ ,  $T_{HYST}$

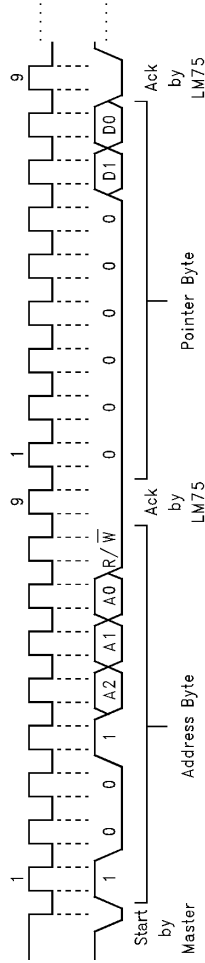

(b) Typical Pointer Set Followed by Immediate Read for 2-Byte Register such as Temp,  $T_{OS}$ ,  $T_{HYST}$

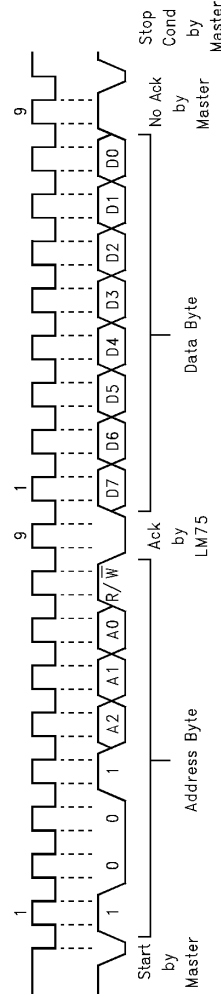

(c) Typical 1-Byte Read From Configuration Register With Preset Pointer

300099810

FIGURE 6. Timing Diagram

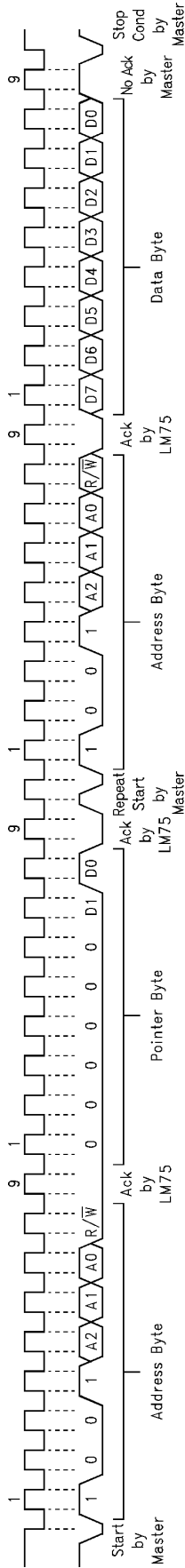

(a) Typical Pointer Set Followed by Immediate Read from Configuration Register

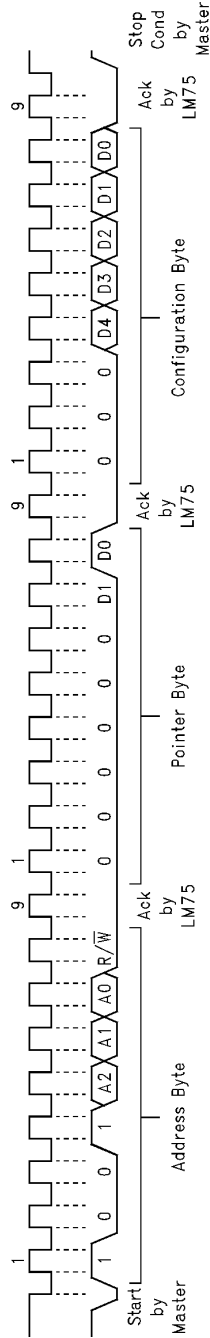

(b) Configuration Register Write

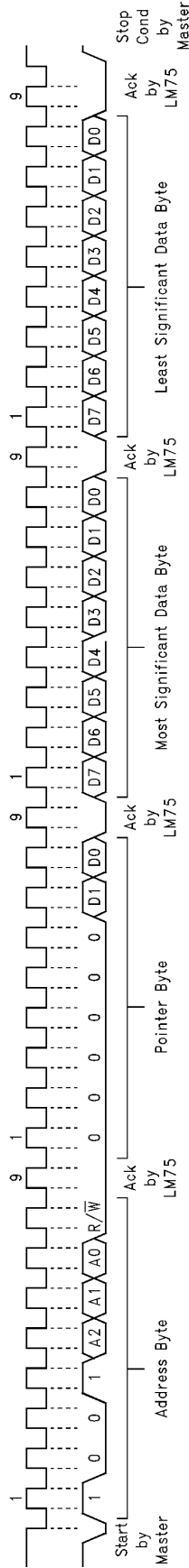

(c)  $T_{OS}$  and  $T_{HYST}$  Write

30099811

FIGURE 7. Timing Diagrams (Continued)

## 2.0 Application Hints

To get the expected results when measuring temperature with an integrated circuit temperature sensor like the LM75, it is important to understand that the sensor measures its own die temperature. For the LM75, the best thermal path between the die and the outside world is through the LM75's pins. In the MSOP-8 package for the LM75B and LM75C, the GND pin is directly connected to the die, so the GND pin provides the best thermal path. If the other pins are at different temperatures (unlikely, but possible), they will affect the die temperature, but not as strongly as the GND pin. In the SO-8 package, none of the pins is directly connected to the die, so they will all contribute similarly to the die temperature. Because the pins represent a good thermal path to the LM75 die, the LM75 will provide an accurate measurement of the temperature of the printed circuit board on which it is mounted. There is a less efficient thermal path between the plastic package and the LM75 die. If the ambient air temperature is significantly different from the printed circuit board temperature, it will have a small effect on the measured temperature.

In probe-type applications, the LM75 can be mounted inside a sealed-end metal tube, and can then be dipped into a bath or screwed into a threaded hole in a tank. As with any IC, the LM75 and accompanying wiring and circuits must be kept insulated and dry, to avoid leakage and corrosion. This is especially true if the circuit may operate at cold temperatures where condensation can occur. Printed-circuit coatings and varnishes such as Humiseal and epoxy paints or dips are often used to insure that moisture cannot corrode the LM75 or its connections.

## 3.0 Typical Applications

### 2.1 DIGITAL NOISE ISSUES

The LM75B features an integrated low-pass filter on both the SCL and the SDA digital lines to mitigate the effects of bus noise. Although this filtering makes the LM75B communication robust in noisy environments, good layout practices are always recommended. Minimize noise coupling by keeping digital traces away from switching power supplies. Also, ensure that digital lines containing high-speed data communications cross at right angles to the SDA and SCL lines.

Excessive noise coupling into the SDA and SCL lines on the LM75C—specifically noise with amplitude greater than  $400\text{ mV}_{pp}$  (the LM75's typical hysteresis), overshoot greater than  $300\text{ mV}$  above  $+V_s$ , and undershoot more than  $300\text{ mV}$  below GND—may prevent successful serial communication with the LM75C. Serial bus no-acknowledge is the most common symptom, causing unnecessary traffic on the bus. The layout procedures mentioned above apply also to the LM75C. Although the serial bus maximum frequency of communication is only  $400\text{ kHz}$ , care must be taken to ensure proper termination within a system with long printed circuit board traces or multiple parts on the bus. Resistance can be added in series with the SDA and SCL lines to further help filter noise and ringing. A  $5\text{ k}\Omega$  resistor should be placed in series with the SCL line, placed as close as possible to the SCL pin on the LM75C. This  $5\text{ k}\Omega$  resistor, with the  $5\text{ pF}$  to  $10\text{ pF}$  stray capacitance of the LM75 provides a  $6\text{ MHz}$  to  $12\text{ MHz}$  low pass filter, which is sufficient filtering in most cases.

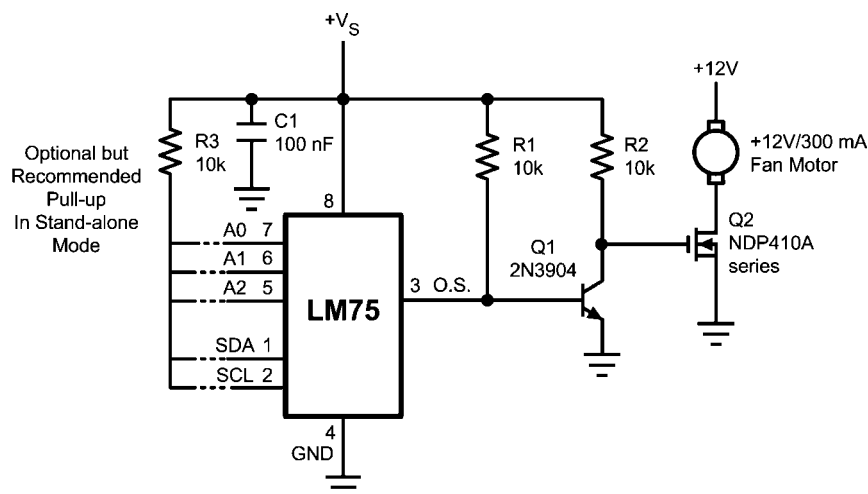

30099812

When using the two-wire interface: program O.S. for active high and connect O.S. directly to Q2's gate.

**FIGURE 8. Simple Fan Controller, Interface Optional**



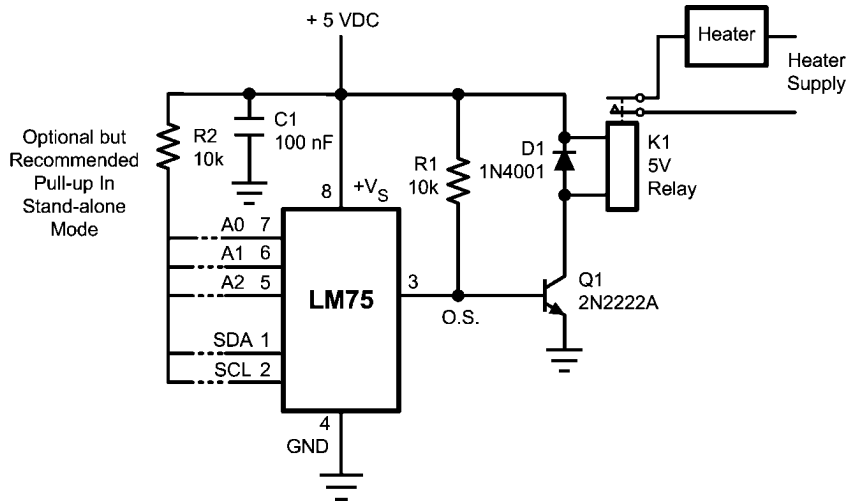

30099814

FIGURE 9. Simple Thermostat, Interface Optional

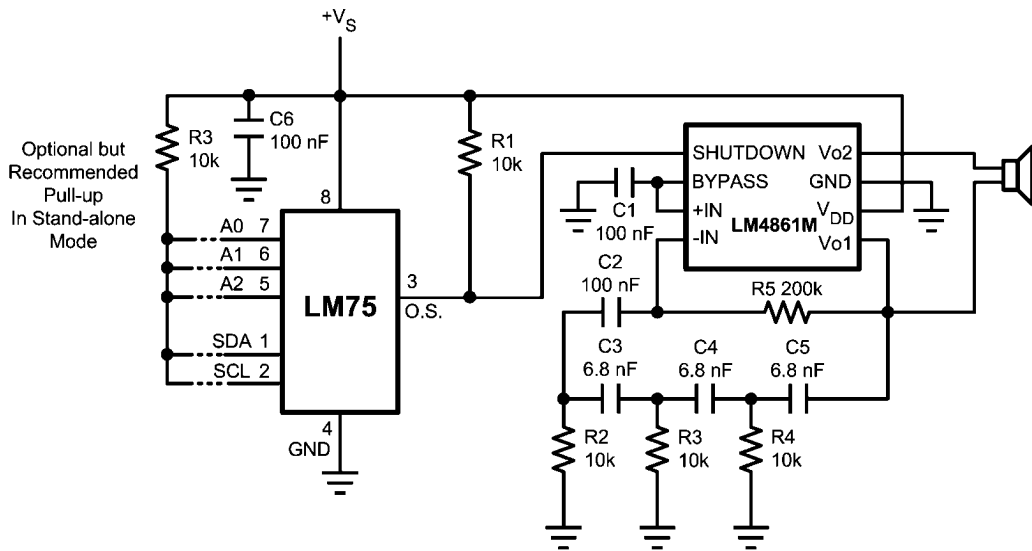

30099815

FIGURE 10. Temperature Sensor with Loudmouth Alarm (Barking Watchdog)

**Physical Dimensions** inches (millimeters) unless otherwise noted

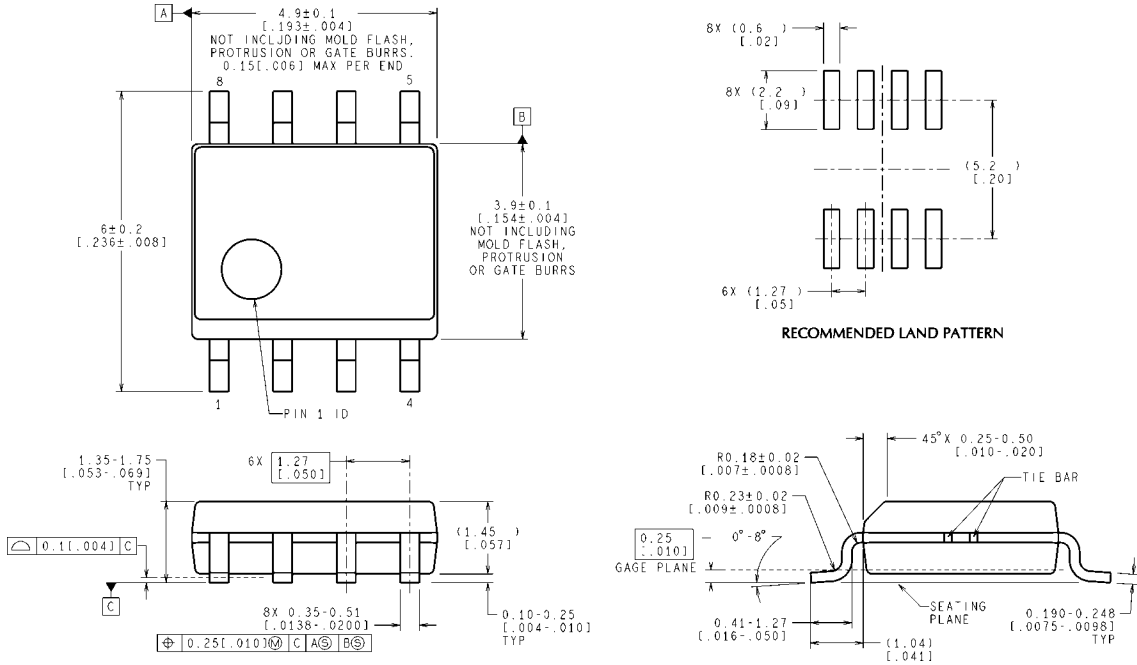

CONTROLLING DIMENSION IS MILLIMETER  
VALUES IN [ ] ARE INCHES  
DIMENSIONS IN ( ) FOR REFERENCE ONLY

M08A (Rev M)

**8-Lead (0.150 Wide) Molded Small Outline Package (SOP), JEDEC  
Order Number LM75CIM-3, LM75CIMX-3, LM75CIM-5, LM75CIMX-5,  
LM75BIM-3, LM75BIMX-3, LM75BIM-5, or LM75BIMX-5  
NS Package Number M08A**

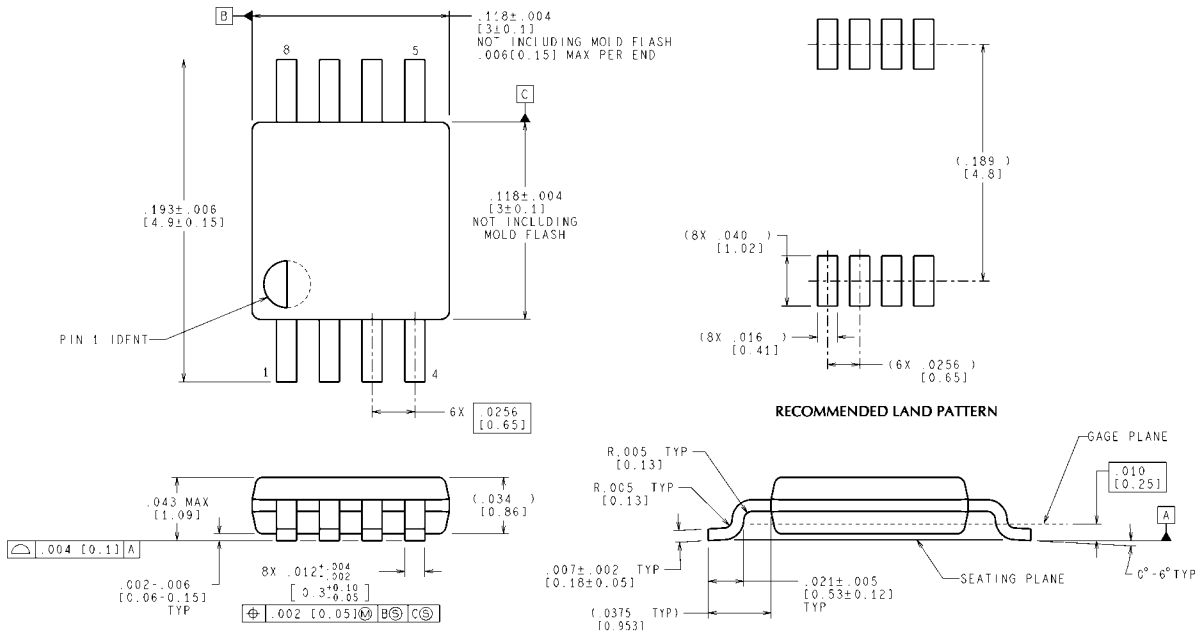

CONTROLLING DIMENSION IS INCH  
VALUES IN [ ] ARE MILLIMETERS

MUA08A (Rev F)

**8-Lead Molded Mini Small Outline Package (MSOP)  
(JEDEC REGISTRATION NUMBER M0-187)  
Order Number LM75CIMM-3, LM75CIMMX-3, LM75CIMM-5, LM75CIMMX-5,  
LM75BIMM-3, LM75BIMMX-3, LM75BIMM-5, or LM75BIMMX-5  
NS Package Number MUA08A**

For more National Semiconductor product information and proven design tools, visit the following Web sites at:  
[www.national.com](http://www.national.com)

Products		Design Support	
Amplifiers	<a href="http://www.national.com/amplifiers">www.national.com/amplifiers</a>	WEBENCH® Tools	<a href="http://www.national.com/webench">www.national.com/webench</a>
Audio	<a href="http://www.national.com/audio">www.national.com/audio</a>	App Notes	<a href="http://www.national.com/appnotes">www.national.com/appnotes</a>
Clock and Timing	<a href="http://www.national.com/timing">www.national.com/timing</a>	Reference Designs	<a href="http://www.national.com/refdesigns">www.national.com/refdesigns</a>
Data Converters	<a href="http://www.national.com/adc">www.national.com/adc</a>	Samples	<a href="http://www.national.com/samples">www.national.com/samples</a>
Interface	<a href="http://www.national.com/interface">www.national.com/interface</a>	Eval Boards	<a href="http://www.national.com/evalboards">www.national.com/evalboards</a>
LVDS	<a href="http://www.national.com/lvds">www.national.com/lvds</a>	Packaging	<a href="http://www.national.com/packaging">www.national.com/packaging</a>
Power Management	<a href="http://www.national.com/power">www.national.com/power</a>	Green Compliance	<a href="http://www.national.com/quality/green">www.national.com/quality/green</a>
Switching Regulators	<a href="http://www.national.com/switchers">www.national.com/switchers</a>	Distributors	<a href="http://www.national.com/contacts">www.national.com/contacts</a>
LDOs	<a href="http://www.national.com/ldo">www.national.com/ldo</a>	Quality and Reliability	<a href="http://www.national.com/quality">www.national.com/quality</a>
LED Lighting	<a href="http://www.national.com/led">www.national.com/led</a>	Feedback/Support	<a href="http://www.national.com/feedback">www.national.com/feedback</a>
Voltage References	<a href="http://www.national.com/vref">www.national.com/vref</a>	Design Made Easy	<a href="http://www.national.com/easy">www.national.com/easy</a>
PowerWise® Solutions	<a href="http://www.national.com/powerwise">www.national.com/powerwise</a>	Applications & Markets	<a href="http://www.national.com/solutions">www.national.com/solutions</a>
Serial Digital Interface (SDI)	<a href="http://www.national.com/sdi">www.national.com/sdi</a>	Mil/Aero	<a href="http://www.national.com/milaero">www.national.com/milaero</a>
Temperature Sensors	<a href="http://www.national.com/tempensors">www.national.com/tempensors</a>	SolarMagic™	<a href="http://www.national.com/solarmagic">www.national.com/solarmagic</a>
PLL/VCO	<a href="http://www.national.com/wireless">www.national.com/wireless</a>	PowerWise® Design University	<a href="http://www.national.com/training">www.national.com/training</a>

THE CONTENTS OF THIS DOCUMENT ARE PROVIDED IN CONNECTION WITH NATIONAL SEMICONDUCTOR CORPORATION ("NATIONAL") PRODUCTS. NATIONAL MAKES NO REPRESENTATIONS OR WARRANTIES WITH RESPECT TO THE ACCURACY OR COMPLETENESS OF THE CONTENTS OF THIS PUBLICATION AND RESERVES THE RIGHT TO MAKE CHANGES TO SPECIFICATIONS AND PRODUCT DESCRIPTIONS AT ANY TIME WITHOUT NOTICE. NO LICENSE, WHETHER EXPRESS, IMPLIED, ARISING BY ESTOPPEL OR OTHERWISE, TO ANY INTELLECTUAL PROPERTY RIGHTS IS GRANTED BY THIS DOCUMENT.

TESTING AND OTHER QUALITY CONTROLS ARE USED TO THE EXTENT NATIONAL DEEMS NECESSARY TO SUPPORT NATIONAL'S PRODUCT WARRANTY. EXCEPT WHERE MANDATED BY GOVERNMENT REQUIREMENTS, TESTING OF ALL PARAMETERS OF EACH PRODUCT IS NOT NECESSARILY PERFORMED. NATIONAL ASSUMES NO LIABILITY FOR APPLICATIONS ASSISTANCE OR BUYER PRODUCT DESIGN. BUYERS ARE RESPONSIBLE FOR THEIR PRODUCTS AND APPLICATIONS USING NATIONAL COMPONENTS. PRIOR TO USING OR DISTRIBUTING ANY PRODUCTS THAT INCLUDE NATIONAL COMPONENTS, BUYERS SHOULD PROVIDE ADEQUATE DESIGN, TESTING AND OPERATING SAFEGUARDS.

EXCEPT AS PROVIDED IN NATIONAL'S TERMS AND CONDITIONS OF SALE FOR SUCH PRODUCTS, NATIONAL ASSUMES NO LIABILITY WHATSOEVER, AND NATIONAL DISCLAIMS ANY EXPRESS OR IMPLIED WARRANTY RELATING TO THE SALE AND/OR USE OF NATIONAL PRODUCTS INCLUDING LIABILITY OR WARRANTIES RELATING TO FITNESS FOR A PARTICULAR PURPOSE, MERCHANTABILITY, OR INFRINGEMENT OF ANY PATENT, COPYRIGHT OR OTHER INTELLECTUAL PROPERTY RIGHT.

**LIFE SUPPORT POLICY**

**NATIONAL'S PRODUCTS ARE NOT AUTHORIZED FOR USE AS CRITICAL COMPONENTS IN LIFE SUPPORT DEVICES OR SYSTEMS WITHOUT THE EXPRESS PRIOR WRITTEN APPROVAL OF THE CHIEF EXECUTIVE OFFICER AND GENERAL COUNSEL OF NATIONAL SEMICONDUCTOR CORPORATION.** As used herein:

Life support devices or systems are devices which (a) are intended for surgical implant into the body, or (b) support or sustain life and whose failure to perform when properly used in accordance with instructions for use provided in the labeling can be reasonably expected to result in a significant injury to the user. A critical component is any component in a life support device or system whose failure to perform can be reasonably expected to cause the failure of the life support device or system or to affect its safety or effectiveness.

National Semiconductor and the National Semiconductor logo are registered trademarks of National Semiconductor Corporation. All other brand or product names may be trademarks or registered trademarks of their respective holders.

Copyright© 2010 National Semiconductor Corporation  
 For the most current product information visit us at [www.national.com](http://www.national.com)



**National Semiconductor Americas Technical Support Center**  
 Email: [support@nsc.com](mailto:support@nsc.com)  
 Tel: 1-800-272-9959

**National Semiconductor Europe Technical Support Center**  
 Email: [europe.support@nsc.com](mailto:europe.support@nsc.com)

**National Semiconductor Asia Pacific Technical Support Center**  
 Email: [ap.support@nsc.com](mailto:ap.support@nsc.com)

**National Semiconductor Japan Technical Support Center**  
 Email: [jpn.feedback@nsc.com](mailto:jpn.feedback@nsc.com)