

**MULTILAYER CERAMIC ANTENNA  
FOR BLUETOOTH & WLAN IEEE 802.11b (2.45G Hz ISM Band)**

**Product Specification**

**QUICK REFERENCE DATA**

Central Frequency*	2.45 GHz	
Bandwidth	>100 MHz	
Gain	1.2dBi max	
VSWR	2.0 max	
Polarization	Linear	
Azimuth	Omni-directional	
Impedance**	50Ω	
Operating Temperature	-55~125 °C	
Termination	Ni/Sn (Environmentally-Friendly Leadless)	
Resistance to soldering heat	260°C, 10 sec.	
Maximum Power	1W	

\* Three types of antenna are available for central frequency adjustment (type 245, type 260, type 270)

\*\* Antenna is built-in internal impedance circuit and ground point can be grounded optionally for matching free purpose.



*Special Environmental Concerns- Green Products Design: The foil making process is using environmentally-friendly aqueous solvent technology. Termination is lead free (Pb free) and packing materials can be re-cycled*

R&D	Print date 01/12/13		Preliminary use only				
	<b>Multilayer Ceramic Antenna for Bluetooth (ISM Band 2.45GHz)</b>		<b>4311 111 00245/260/270 4312 111 00245/260/270</b>				2001-2-22
							2001-6-19 2001-7-10
Grant Lin/Cliff		2001-7-10	Page 1	sheet 190-1			A4
spec.doc	Phycomp Taiwan Ltd.						

## APPLICATION

### Suggested Layout

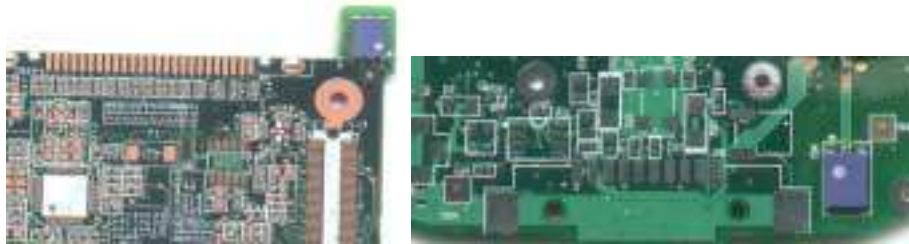
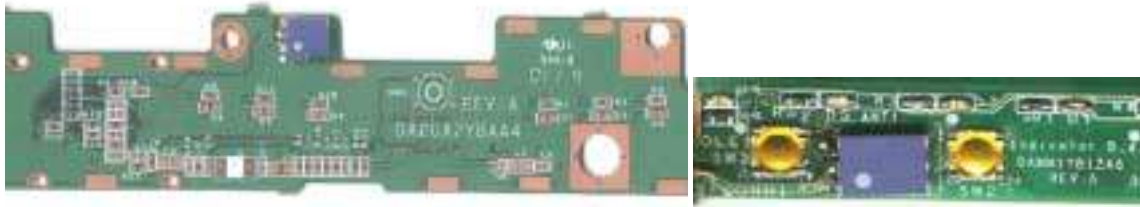
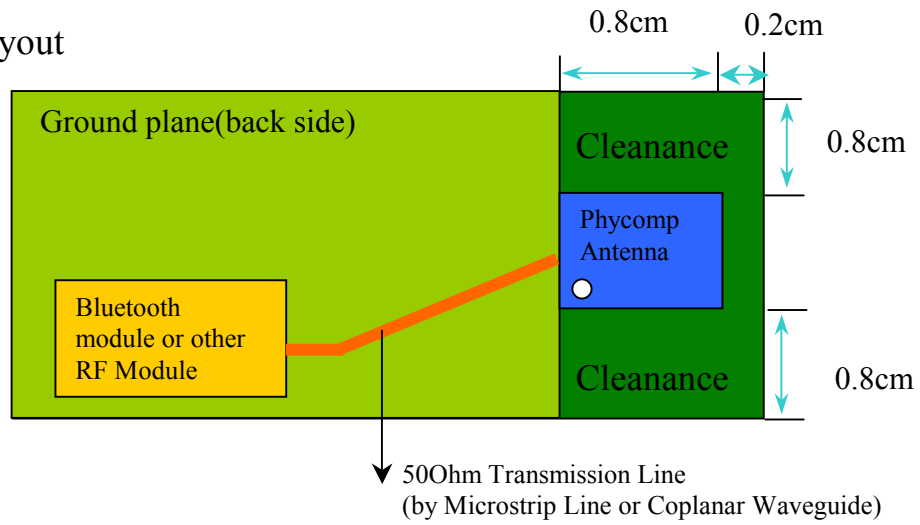

*Bluetooth Notebooks and PDAs with Phycomp Antenna*



*IEEE 802.11b WLAN Cards with Phycomp Antenna*

R&D	Print date 01/12/13		Preliminary use only		
	Multilayer Ceramic Antenna for Bluetooth (ISM Band 2.45GHz)	4311 111 00245/260/270 4312 111 00245/260/270	2001-2-22		
			2001-6-19 2001-7-10		
Grant Lin/Cliff	2001-7-10	Page 2	sheet 190-2		A4
spec.doc	Phycomp Taiwan Ltd.				

## DIMENSIONAL DATA

Figure	Dimension	Port	
	L	7.35±0.25 mm	-
	W	5.5±0.2 mm	-
	T	1.3±0.2 mm	-
	F	0.9±0.25 mm	Feed Termination
	G	1.25±0.35 mm	Ground Termination ( <u>Optional*</u> )
	C	0.5±0.3 mm	-
	S1	1.25±0.35 mm	NC Solder Termination
	S2	1.25±0.35 mm	NC Solder Termination
	S3	0.9±0.25 mm	NC Solder Termination
	S4	1.25±0.35 mm	NC Solder Termination

\* Antenna has a built-in circuit at Ground Termination. However, Ground Termination is optional if good matching is attainable. If good matching is attainable during application, Ground Termination can be used as NC Solder Termination.

## SOLDER LAND PATTERN

Figure	Dimensions	Remark	
	L	8.30 ± 0.10 mm	
	W	5.70 ± 0.10 mm	
	F	1.00 ± 0.10 mm	Feed Pad
	G	1.40 ± 0.10 mm	Ground Pad ( <u>Optional*</u> )
	C	0.90 ± 0.10 mm	
	S1	1.40 ± 0.10 mm	NC Mount Pad
	S2	1.40 ± 0.10 mm	NC Mount Pad
	S3	1.00 ± 0.10 mm	NC Mount Pad
S4	1.40 ± 0.10 mm	NC Mount Pad	

R&D	Print date 01/12/13	Preliminary use only			
	Multilayer Ceramic Antenna for Bluetooth (ISM Band 2.45GHz)	4311 111 00245/260/270		2001-2-22	
		4312 111 00245/260/270		2001-6-19 2001-7-10	
Grant Lin/Cliff	2001-7-10	Page 3	sheet 190-3		A4
spec.doc	Phycomp Taiwan Ltd.				

## ELECTRICAL DATA

Central Frequency	2.45 GHz
Bandwidth	100 MHz
Gain	0 ~ 1.2dBi
VSWR	2.0 max
Polarization	Linear
Azimuth Beamwidth	Omni-directional
Impedance	50Ω
Operating Temperature	-55~125 °C
Termination	Ni/Sn (Environmental Friendly Leadless)
Resistance to soldering heat	260°C, 10 sec.
Maximum Power	1W

### Radiation Pattern Polar plot

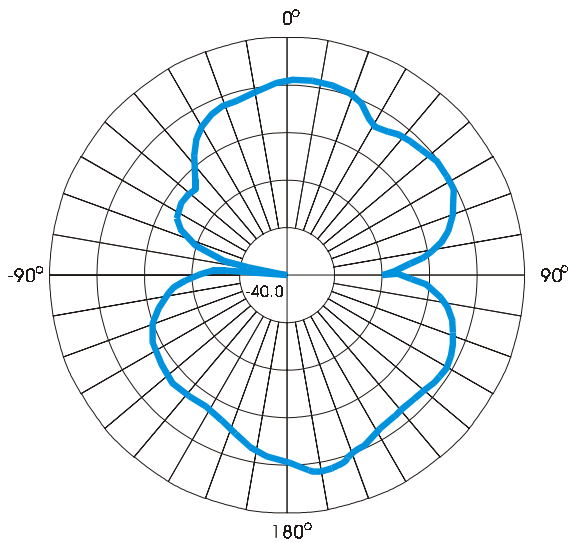

E Plane

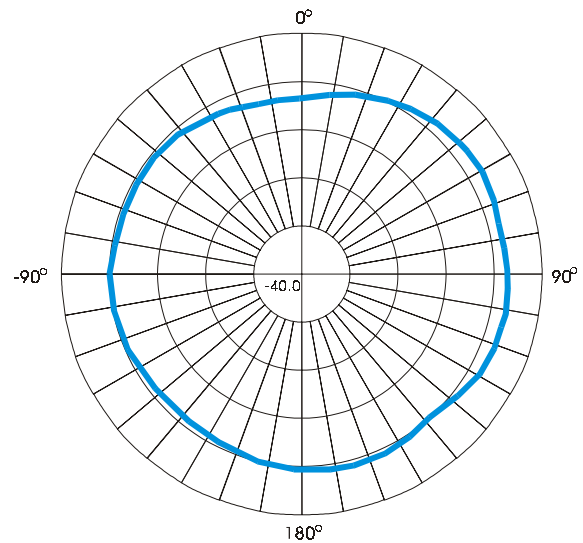

H Plane

R&D	Print date 01/12/13		Preliminary use only		
	Multilayer Ceramic Antenna for Bluetooth (ISM Band 2.45GHz)		4311 111 00245/260/270		2001-2-22
			4312 111 00245/260/270		2001-6-19 2001-7-10
Grant Lin/Cliff	2001-7-10	Page 4	sheet 190-4		A4
spec.doc	Phycomp Taiwan Ltd.				

## STANDARD TEST BOARD FOR RADIATION PATTERN & SWR

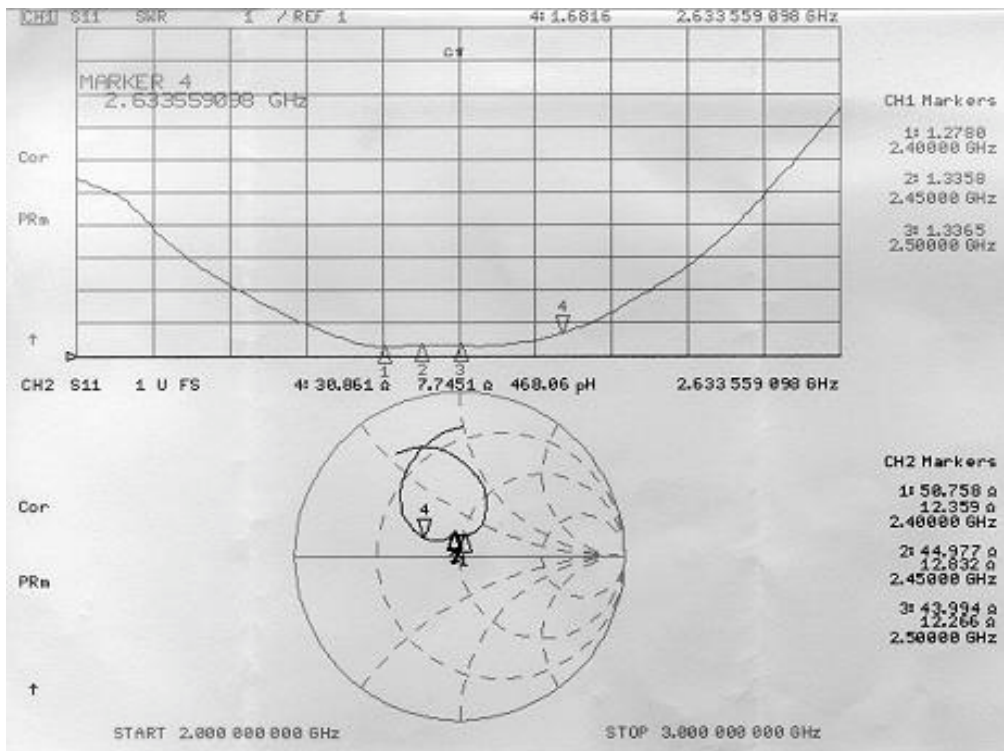
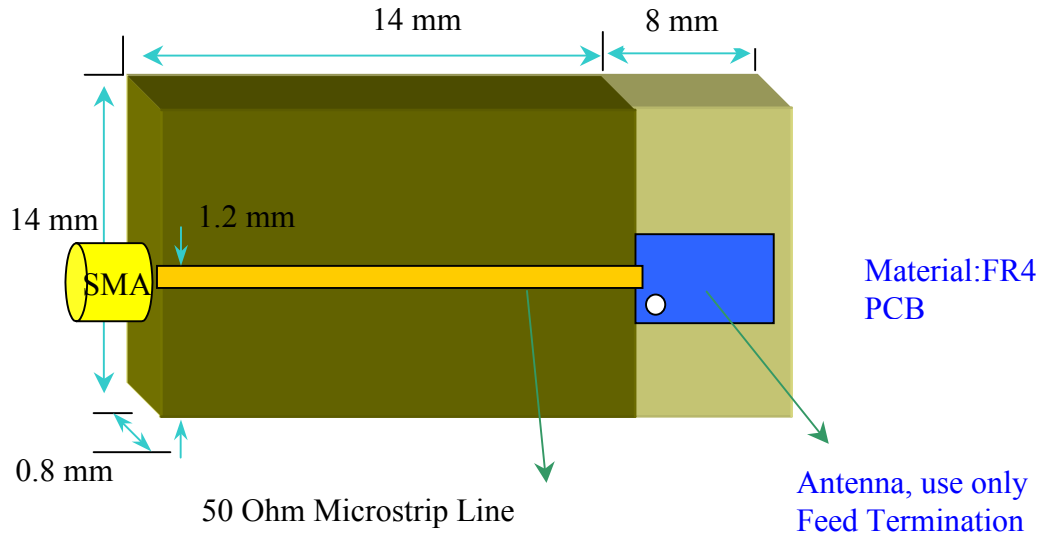

R&D	Print date 01/12/13	Preliminary use only			
	Multilayer Ceramic Antenna for Bluetooth (ISM Band 2.45GHz)	4311 111 00245/260/270		2001-2-22	
		4312 111 00245/260/270		2001-6-19 2001-7-10	
Grant Lin/Cliff		2001-7-10	Page 5	sheet 190-5	A4
spec.doc	Phycomp Taiwan Ltd.				

**RELIABILITY DATA (Reference to IEC Specification)**

IEC 384-10/ CECC 32 100 CLAUSE	IEC 60068-2 TEST METHOD	TEST	PROCEDURE	REQUIREMENTS
4.4		Mounting	The antenna can be mounted on printed-circuit boards or ceramic substrates by applying wave soldering, reflow soldering (including vapour phase soldering) or conductive adhesive	No visible damage
4.5		Visual inspection and dimension check	Any applicable method using $\times 10$ magnification	In accordance with specification (chip off 4mm)
4.6.1		Antenna	Frequency = 2.45 GHz; at 20 °C	Standard test board in page 4
4.8		Adhesion	A force of 5 N applied for 10 s to the line joining the terminations and in a plane parallel to the substrate	No visible damage
4.9		Bond strength of plating on end face	Mounted in accordance with CECC 32 100, paragraph 4.4	No visible damage
			Conditions: bending 1mm at a rate of 1mm/s, radius jig. 340 mm, 2mm warp on FR4 board of 90 mm length	No visible damage

R&D	Print date 01/12/13		Preliminary use only			
	<b>Multilayer Ceramic Antenna for Bluetooth (ISM Band 2.45GHz)</b>		<b>4311 111 00245/260/270</b> <b>4312 111 00245/260/270</b>		2001-2-22	
					2001-6-19 2001-7-10	
Grant Lin/Cliff	2001-7-10	Page 6	sheet 190-6			A4
spec.doc	Phycomp Taiwan Ltd.					

<b>IEC 384-10/ CECC 32 100 CLAUSE</b>	<b>IEC 60068-2 TEST METHOD</b>	<b>TEST</b>	<b>PROCEDURE</b>	<b>REQUIREMENTS</b>
4.10	20(Tb)	Resistance to soldering heat	260 ± 5 °C for 10 ± 0.5 s in a static solder bath	The terminations shall be well tinned after recovery and Central Freq. Change ± 6%
		Resistance to leaching	260 ± 5 °C for 30 ± 1 s in a static solder bath	Using visual enlargement of × 10, dissolution of the termination shall not exceed 10%
4.11	20(Ta)	Solderability	Zero hour test, and test after storage (20 to 24 months) in original atmosphere; un-mounted chips completely immersed for 2 ± 0.5 s in 235 ± 5°C.	The termination must be well tinned, at least 75% is well tinned at termination
4.12	4(Na)	Rapid change of temperature	-55 °C (30 minutes) to +125 °C (30 minutes); 100 cycles	No visible damage Central Freq. Change ± 6%
4.14	3(Ca)	Damp heat	500 ± 12 hours at 60 °C; 90 to 95 % RH	No visible damage 2 hours recovery Central Freq. Change ± 6%
4.15		Endurance	500 ± 12 hours at 125 °C;	No visible damage 2 hours recovery Central Freq. Change ± 6%

R&D	Print date 01/12/13		Preliminary use only			
	<b>Multilayer Ceramic Antenna for Bluetooth (ISM Band 2.45GHz)</b>		<b>4311 111 00245/260/270 4312 111 00245/260/270</b>		2001-2-22	
					2001-6-19 2001-7-10	
Grant Lin/Cliff	2001-7-10	Page 7	sheet 190-7			A4
spec.doc	Phycomp Taiwan Ltd.					

**ORDERING INFORMATION: Method I- by 12NC Ordering Code**

The antennas may be ordered by using the 12 NC ordering code. These code numbers can be determined by the following rules:

4311 1 11 00 245  
 F C M S T A

F. Family Code

**43** = Antenna

C. Packing Type Code

**11** = 180 mm/ 7" blister (1000pcs) , **12** = 330 mm/13" blister (4000 pcs)

**13** = Bulk (1000 pcs)

M. Materials Code

**1** = High Frequency Material

S. Size Code

**11** = 7.35 \* 5.5 \* 1.3 mm

T. Tolerance

**00** = 100 M Hz Band Width

A. Working Frequency (three types of antenna are available)

**245** = 2.45 GHz

Type 245

**260** = (2.45+0.15) GHz \* Intention for shift up 150MHz

Type 260

**270** = (2.45+0.25) GHz \* Intention for shift up 250MHz

Type 270

**Example: 12NC 4311 111 00245**  
 Product description: Antenna (43) by 180 mm blister (11) of High Frequency Material (1), Size 7.35\*5.5\*1.3 mm (1);  
 Tolerance (00) of 100 MHz (VSWR<2)  
 Working Frequency (245) = 2.45G Hz

**ORDERING INFORMATION: Method II- by Clear Text Code**

The antennas may be ordered by using the 16-digit clear text ordering code. These code numbers can be determined by the following rules:

AN2450000707051K (Clear Text Code Example)						
AN	2450	00	07	0705	1	K
Product	Central Freq.	Bandwidth	Material	Size	Quantities	Packing
AN= Antenna	2450=2.45GHz 2600=2.60GHz 2700=2.70GHz	00=>100MHz	07=K7	0705=07*05*1.3 mm	1 = 1K 4 = 4K	K=7" plastic F =13" plastic B = Bulk

R&D	Print date 01/12/13		Preliminary use only			
	Multilayer Ceramic Antenna for Bluetooth (ISM Band 2.45GHz)		4311 111 00245/260/270 4312 111 00245/260/270		2001-2-22	
					2001-6-19 2001-7-10	
Grant Lin/Cliff		2001-7-10	Page 8	sheet 190-8		A4
spec.doc	Phycomp Taiwan Ltd.					



## Taping Blister Tape

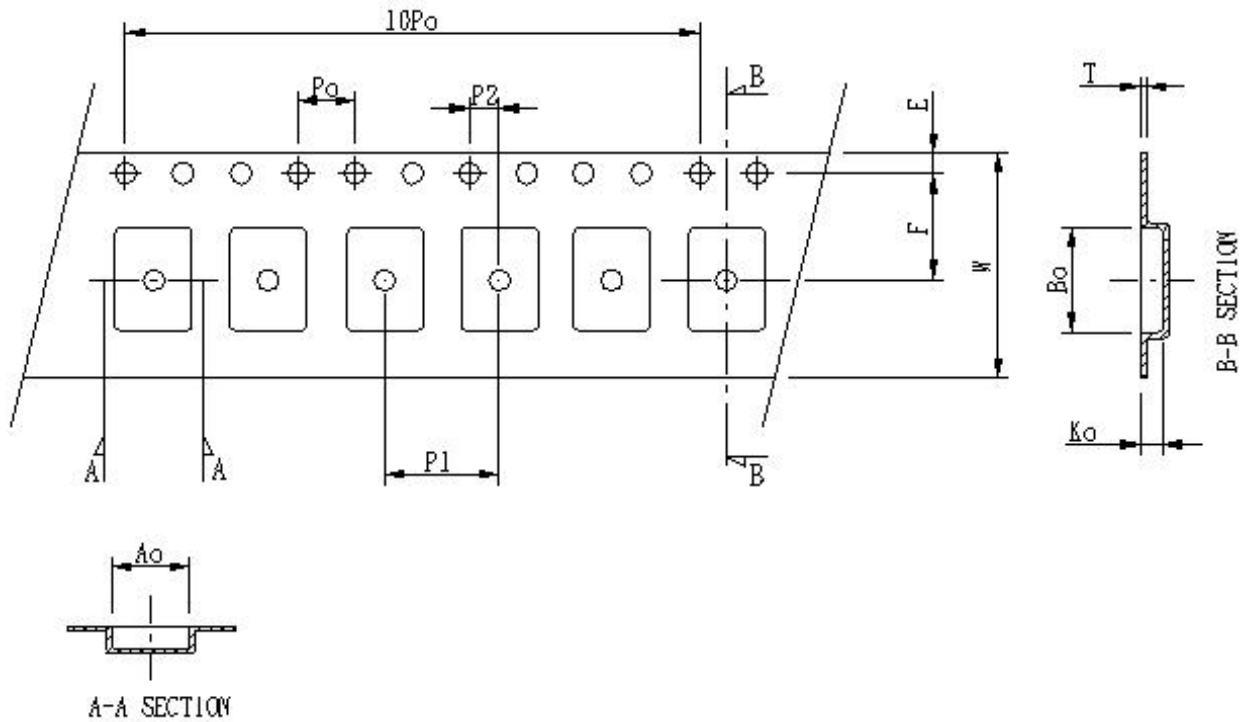

### DIMENSION:

Serial no	Checking note	Index	Spec(mm)
1	Sprocket hole	$D_o$	$1.55 \pm 0.10$
2	Pocket hole	$D_1$	$1.50 \pm 0.10$
3	Distance sprocket hole/sprocket hole	$P_o$	$4.0 \pm 0.10$
4	Distance pocket/pocket	$P_1$	$8.0 \pm 0.10$
5	Distance sprocket hole/pocket	$P_2$	$2.0 \pm 0.10$
6	Tape width	$W$	$16.0 \pm 0.30$
7	Distance sprocket hole/outside	$E$	$1.75 \pm 0.10$
8	Distance sprocket hole/pocket	$F$	$7.50 \pm 0.10$
9	Pocket length	$A_o$	$5.85 \pm 0.10$
10	Pocket length	$B_o$	$7.60 \pm 0.10$
11	Pocket depth	$K_o$	$1.70 \pm 0.10$
12	Thickness of tape	$T$	$0.30 \pm 0.10$
13	10x sprocket hole pitch	$10P_o$	$40.0 \pm 0.10$

R&D	Print date 01/12/13	Preliminary use only		
	<b>Multilayer Ceramic Antenna for Bluetooth (ISM Band 2.45GHz)</b>	<b>4311 111 00245/260/270</b> <b>4312 111 00245/260/270</b>	2001-2-22	
			2001-6-19 2001-7-10	
Grant Lin/Cliff	2001-7-10	Page 9	sheet 190-9	A4
spec.doc	Phycomp Taiwan Ltd.			

## 7”(180mm) Reel Specifications

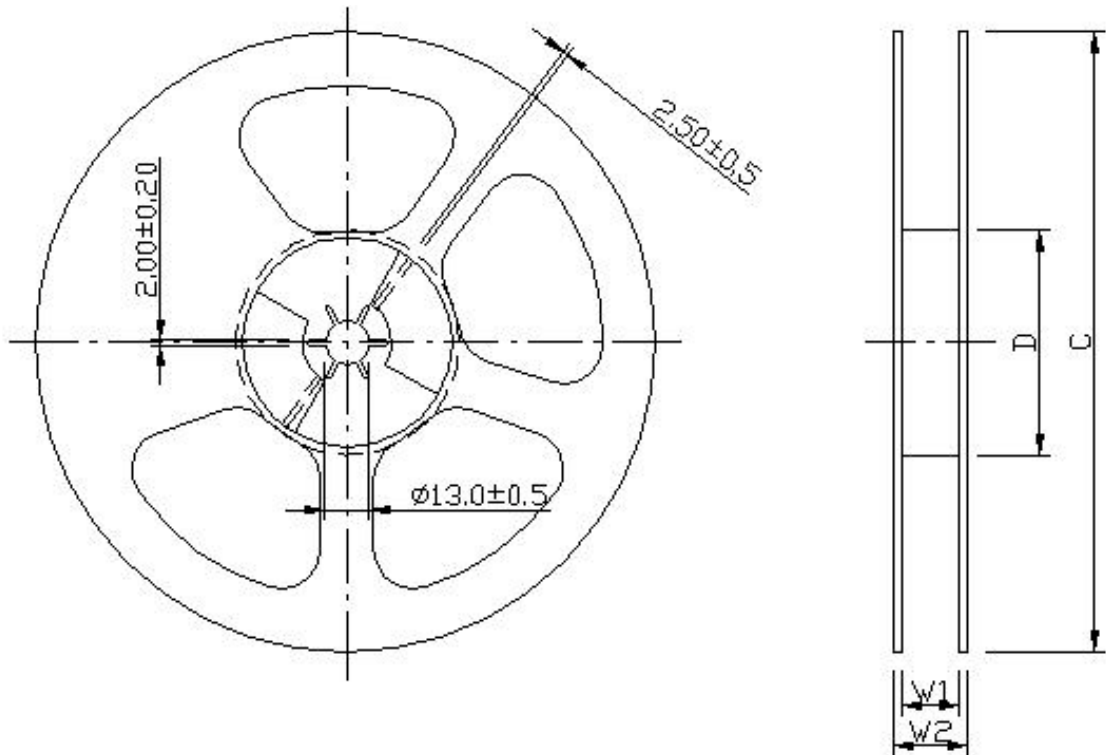

Product size code	Units per Reel	Tape Width (mm)	C (mm)	D (mm)	$W_1$ (mm)	$W_2$ (mm)
Antenna	1000	16	$180.0 \pm 1.0$	$62 \pm 0.5$	$16.0^{+1}_{-0}$	$20.5 \pm 0.2$

R&D	Print date 01/12/13		Preliminary use only		
	Multilayer Ceramic Antenna for Bluetooth (ISM Band 2.45GHz)		4311 111 00245/260/270 4312 111 00245/260/270		2001-2-22
					2001-6-19 2001-7-10
Grant Lin/Cliff	2001-7-10	Page 10	sheet 190-10		A4
spec.doc	Phycomp Taiwan Ltd.				

## 13”(330mm) Reel Specifications

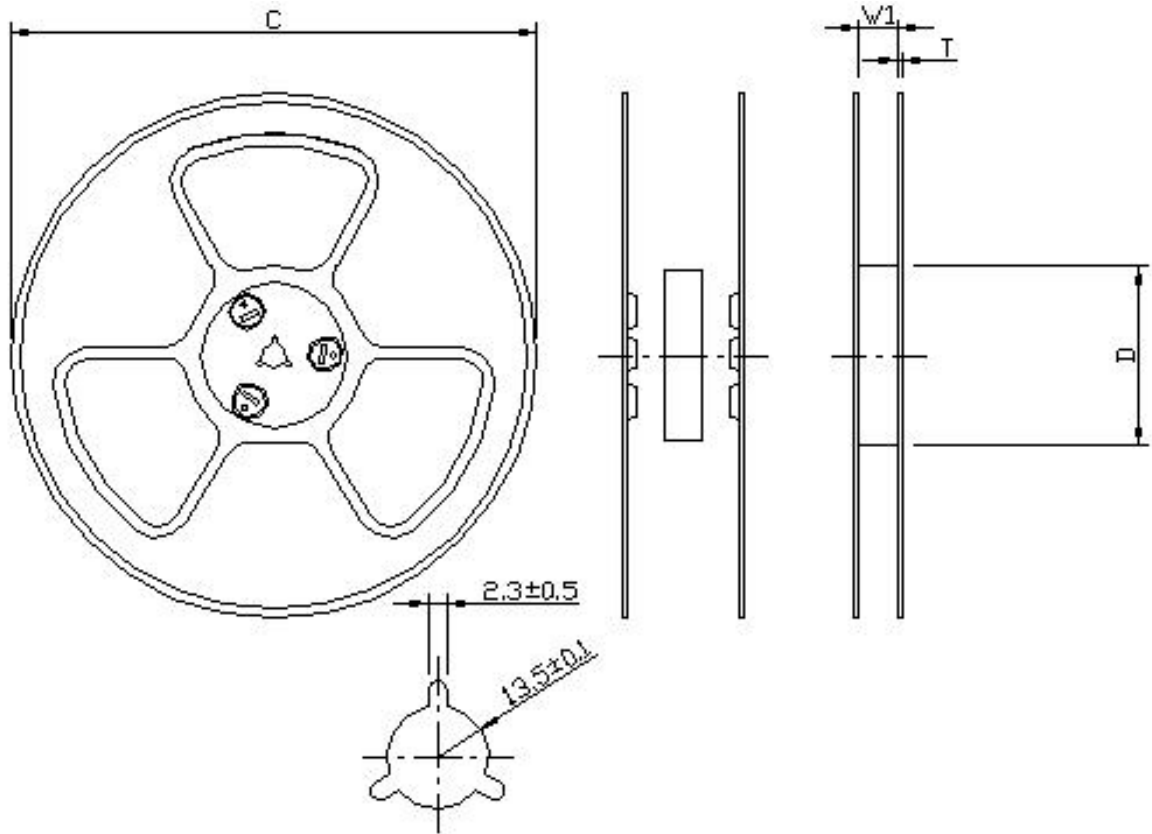

Product size code	Units per Reel	Tape Width (mm)	C (mm)	D (mm)	W <sub>1</sub> (mm)	T (mm)
Antenna	4000	16	330±0.10	100±0.1	16.5±0.10	2.3±0.1

R&D	Print date 01/12/13	Preliminary use only			
	<b>Multilayer Ceramic Antenna for Bluetooth (ISM Band 2.45GHz)</b>	<b>4311 111 00245/260/270</b> <b>4312 111 00245/260/270</b>	2001-2-22		
			2001-6-19 2001-7-10		
Grant Lin/Cliff	2001-7-10	Page 11	sheet 190-11	A4	
spec.doc	Phycomp Taiwan Ltd.				