

Evaluation Board for the **ADP5133** Micro PMU

FEATURES

- Full-featured evaluation board for the [ADP5133](#)**
- Standalone capability**
- Simple device measurements, including line and load regulation, demonstrable with**
 - A single voltage supply**
 - A voltage meter**
 - A current meter**
 - Load resistors**
- Easy access to external components**
- Dedicated enable option for each channel**
- Mode option to change bucks from PSM to PWM operation**

GENERAL DESCRIPTION

This user guide describes the hardware for the evaluation of the [ADP5133](#) and includes detailed schematics and PCB layouts. The [ADP5133](#) is available in a 16-ball, 2mm × 2mm WLCSP package.

The [ADP5133](#) evaluation board enables evaluation of the [ADP5133](#) dual step-down regulator. The evaluation board is available in standard voltage options.

Full details on the [ADP5133](#) are provided in the [ADP5133](#) data sheet available from Analog Devices, Inc., which should be consulted in conjunction with this evaluation board user guide.

DIGITAL PICTURE OF THE EVALUATION BOARD

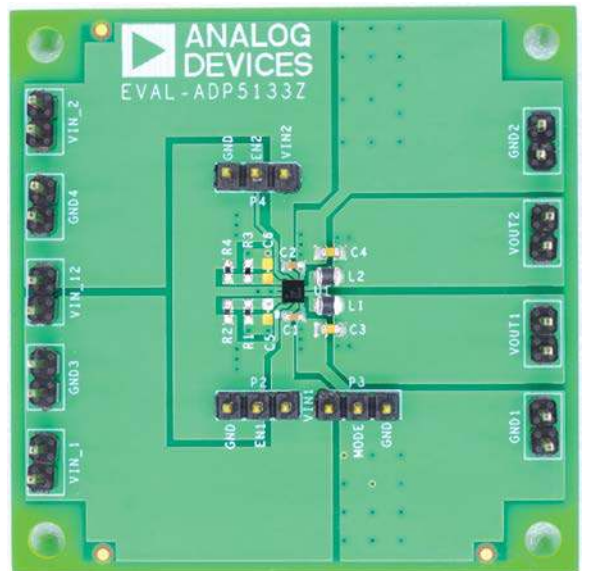

Figure 1.

TABLE OF CONTENTS

Features	1	Measuring Output Voltage	5
General Description	1	Measuring Ground Current	6
Digital Picture of the Evaluation Board.....	1	Evaluation Board Schematics and Artwork.....	7
Revision History	2	Ordering Information.....	10
Using the Evaluation Board.....	3	Bill of Material	10
Powering Up the Evaluation Board.....	3		
Measuring Evaluation Board Performance	4		

REVISION HISTORY

5/14—Revision 0: Initial Version

USING THE EVALUATION BOARD

POWERING UP THE EVALUATION BOARD

The ADP5133 evaluation board is supplied fully assembled and tested. Before applying power to the evaluation board, follow the procedures in this section.

Setting the Output Voltage of the Bucks

The buck output voltage is set through external resistor dividers shown in Figure 2 for BUCK1. Optionally, the output voltage can be factory programmed to default values as indicated in the data sheet. In this event, R1 and R2 are not needed, and FB1 can be left unconnected. In all cases, VOUT1 must be connected to the output capacitor. V_{FB1} is 0.5 V.

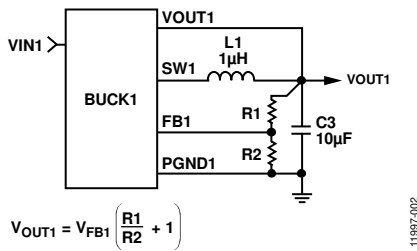

Figure 2. BUCK1 External Output Voltage Setting

The ADP5133 demo boards are supplied with fixed resistors with values chosen for a target output voltage. Varying the resistor values of the resistor divider networks varies the output voltage accordingly.

Table 1. External Resistor Dividers (Fixed)

Resistor Divider	BUCK1	BUCK2
R _{TOP}	R1	R3
R _{BOT}	R2	R4

Enable P2 (EN1) and P4 (EN2)

When the ADP5133 has an input voltage above the minimum UVLO setting, the ADP5133 BUCK1 is enabled by connecting EN1 to VIN1. BUCK2 is enabled by connecting EN2 to VIN2.

Jumper P3 (MODE)

A jumper across Pin 1 and Pin 2 of P3 connects the MODE pin to VIN1, which sets BUCK1 and BUCK2 into forced PWM operation. Meanwhile, a link across Pin 2 and Pin 3 of P3 connects the MODE pin to GND allows BUCK1 and BUCK2 to operate in automatic PWM/PSM operation.

Input Power Source

If the input power source includes a current meter, use that current meter to monitor the input current. Connect the positive terminal of the power source to VIN1 on the evaluation board, and the negative terminal of the power source to GND3.

If the power source does not include a current meter, connect a current meter in series with the input source voltage. Connect the positive lead (+) of the power source to the current meter positive (+) connection, the negative lead (-) of the power source to GND1 on the evaluation board, and the negative lead (-) of the current meter to VIN1 on the board. Be aware that current meters add resistance to the input source and this voltage reduces with high output currents.

Output Load

Connect an electronic load or resistor to set the load current. If the load includes a current meter, or if the current is not measured, connect the load directly to the evaluation board, with the positive (+) load connected to one of the channels. For example, connect BUCK1, VOUT1, and the negative (-) load connection to GND1.

If a current meter is used, connect it in series with the load. Connect the positive (+) current meter terminal to the evaluation board for BUCK1, VOUT1, the negative (-) current meter terminal to the positive (+) load terminal, and the negative (-) load terminal to GND1 on the evaluation board.

Input and Output Voltmeters

Measure the input and output voltages with voltmeters. Make sure that the voltmeters are connected to the appropriate evaluation board terminals and not to the load or power source themselves.

If the voltmeters are not connected directly to the evaluation board, the measured voltages will be incorrect due to the voltage drop across the leads and/or connections between the evaluation board, the power source, and/or the load.

Connect the input voltage measuring voltmeter positive terminal (+) to VIN_1 on the evaluation board, and the negative (-) terminal to GND3 on the evaluation board.

Connect the output voltage measuring voltmeter positive (+) terminal to VOUT1 on the evaluation board for measuring the output voltage of BUCK1 and the negative (-) terminal to GND1 on the evaluation board.

Voltage Input for the Buck Regulators

When the input voltage for BUCK1 and BUCK2 come from different sources, make sure that Pin 1 and Pin 2 of VIN_12 are not shorted. Meanwhile when using the same voltage input for the bucks, place a link across VIN_12.

Turning On the Evaluation Board

When the power source and load are connected to the ADP5133 evaluation board, the board can be powered for operation. Perform the following steps:

1. Ensure that the power source voltage is greater than 4.2 V and less than 5.5 V.
2. Ensure that the desired channel is enabled and monitor the output voltage.

If the load is not already enabled, enable the load; check that it is drawing the proper current, and that the output voltage maintains voltage regulation.

MEASURING EVALUATION BOARD PERFORMANCE

Measuring Output Voltage Ripple on the Buck Regulator

To observe the output voltage ripple of BUCK1, place an oscilloscope probe across the output capacitor (C3) with the probe ground lead at the negative (-) capacitor terminal and the probe tip at the positive (+) capacitor terminal. Set the oscilloscope to ac, 20 mV/division, and 2 μs/division time base.

Measuring the Switching Waveform

To observe the switching waveform with an oscilloscope, place the oscilloscope probe tip at the end of the inductor with the probe ground at GND. Set the oscilloscope to dc, 2 V/division, and 2 μs/division time base.

Measuring Load Regulation

Test the load regulation by increasing the load at the output and looking at the change in output voltage. To minimize voltage drop, use short low resistance wires, especially for loads approaching maximum current.

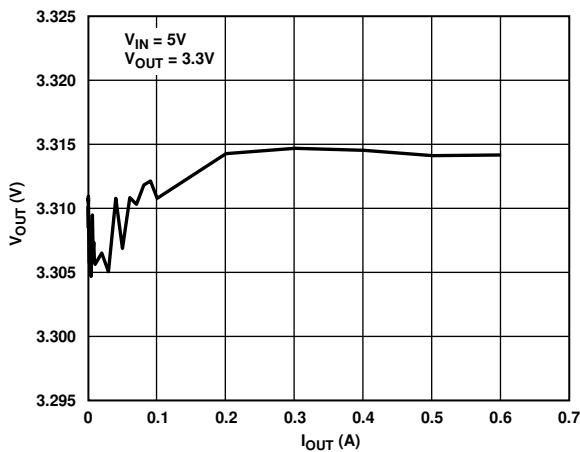

Figure 3. Buck Load Regulation

11997-003

Measuring Line Regulation

Vary the input voltage and examine the change in the output voltage.

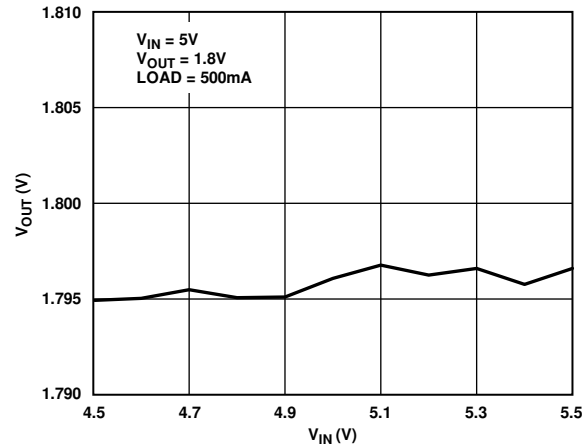

Figure 4. Line Regulation

11997-004

Measuring Efficiency

Measure the efficiency, η, by comparing the input power with the output power.

$$\eta = \frac{V_{OUT} \times I_{OUT}}{V_{IN} \times I_{IN}}$$

Measure the input and output voltages as close as possible to the input and output capacitors to reduce the effect of IR drops.

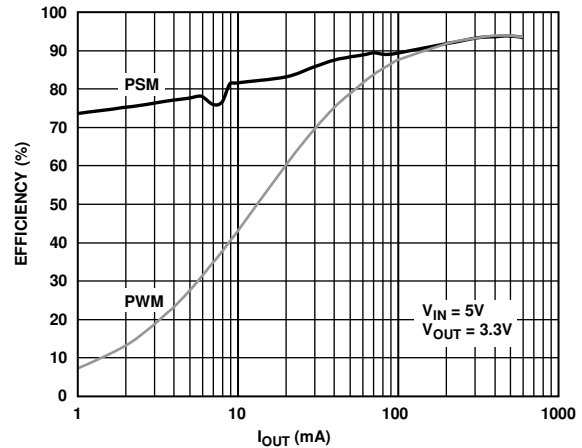

Figure 5. Buck Efficiency

11997-005

Measuring Inductor Current

Measure the inductor current by removing one end of the inductor from its pad and connecting a current loop in series. A current probe can be connected onto this wire.

MEASURING OUTPUT VOLTAGE

Figure 6 shows how the evaluation board can be connected to a voltage supply and a voltmeter for basic output voltage accuracy measurements. A resistor can be used as the load for the regulator. Ensure that the resistor has a power rating adequate

to handle the power expected to be dissipated across it. An electronic load can also be used as an alternative. Ensure that the voltage supply can supply enough current for the expected load levels.

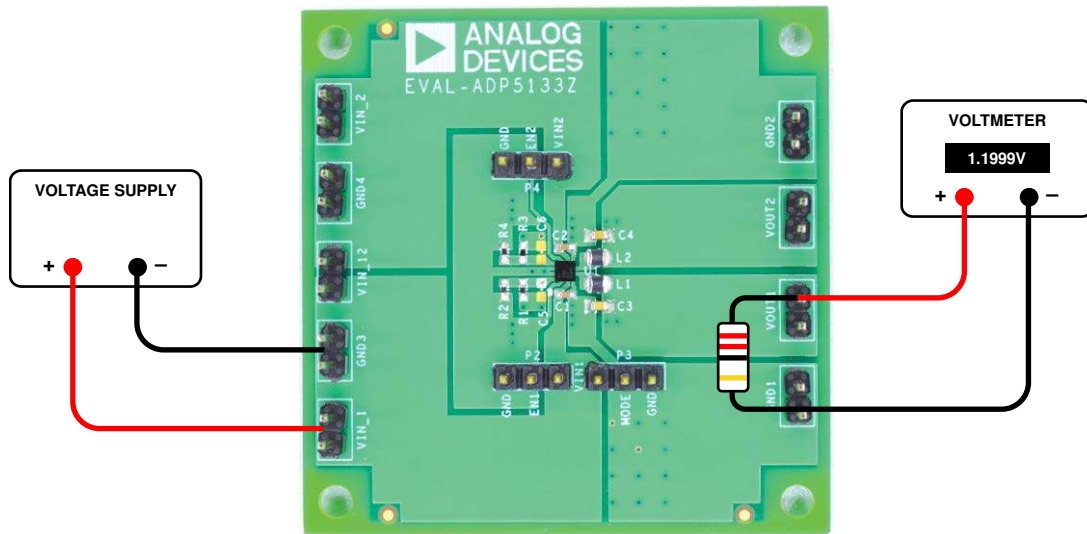

Figure 6. Output Voltage Measurement

11997-006

MEASURING GROUND CURRENT

Figure 7 shows the evaluation board connected to a voltage supply and a current meter for ground current measurements. A resistor can be used as the load for the regulator. Ensure that the resistor has a power rating that is adequate to handle the power

expected to be dissipated across it. An electronic load can be used as an alternative. Ensure that the voltage source used can supply enough current for the expected load levels.

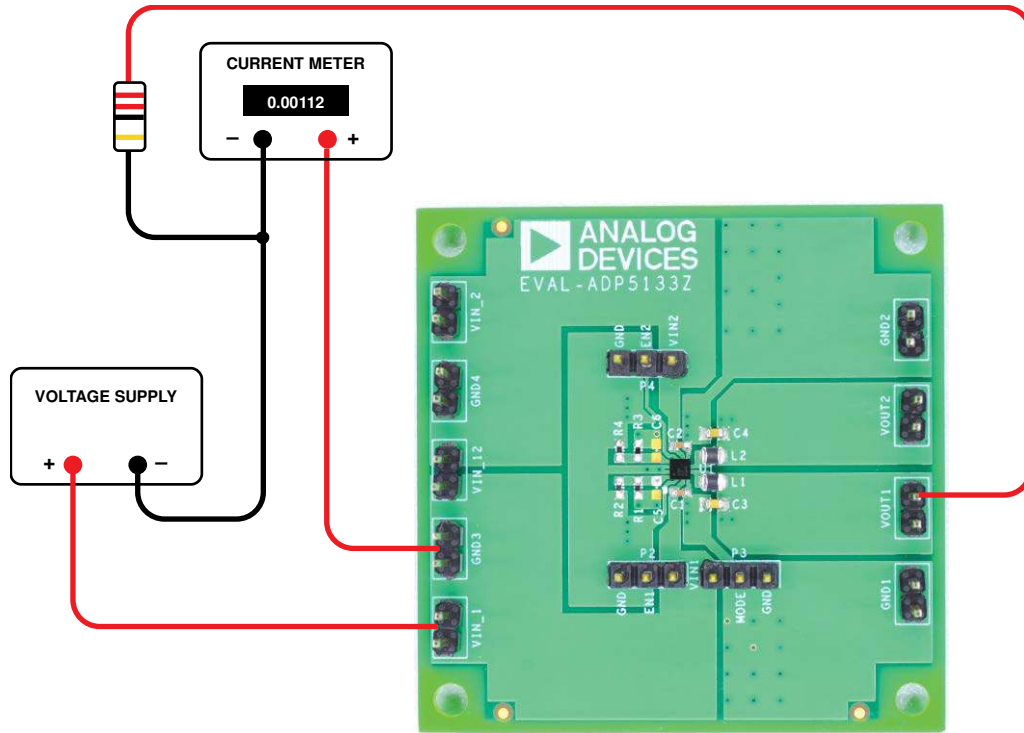

Figure 7. Ground Current Measurement

11897-007

EVALUATION BOARD SCHEMATICS AND ARTWORK

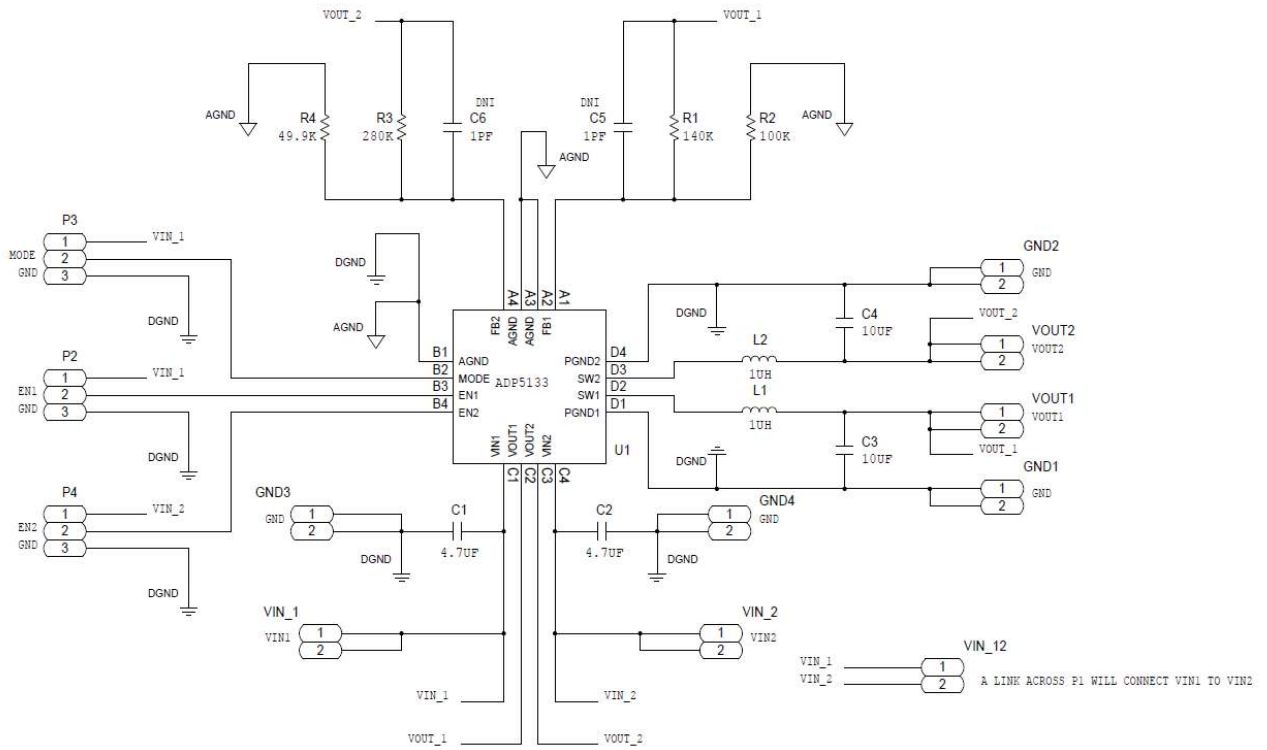

Figure 8. ADP5133 Evaluation Board Schematic

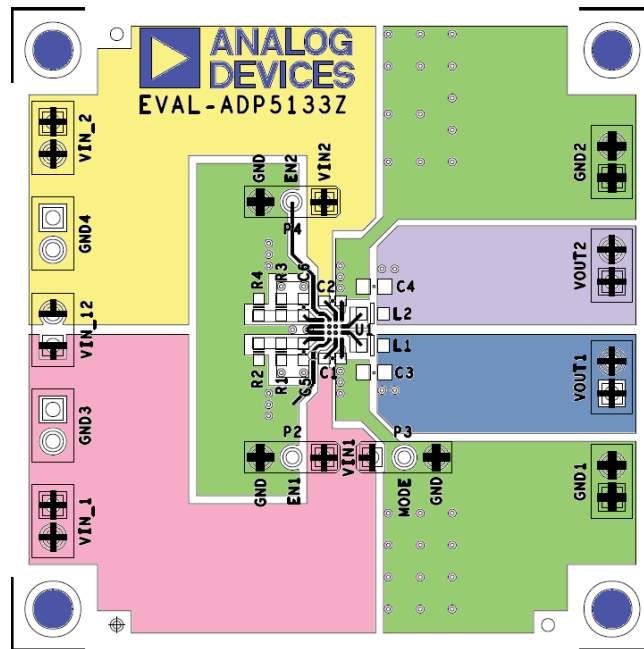
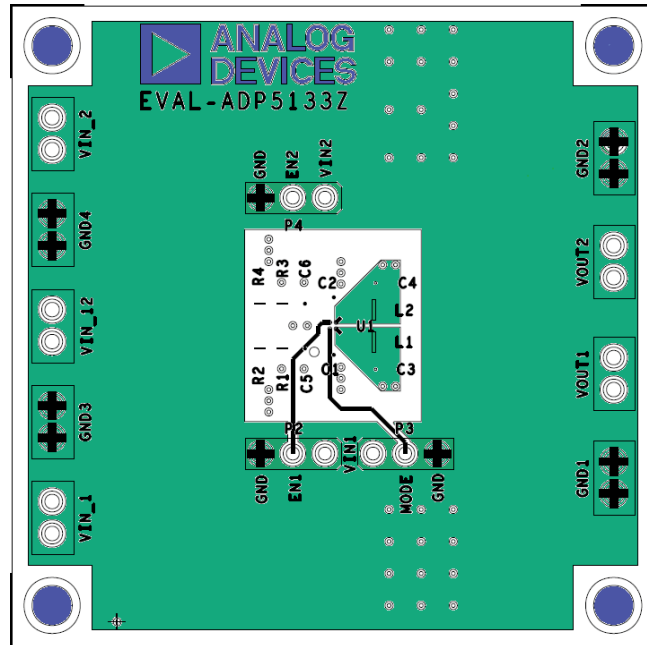
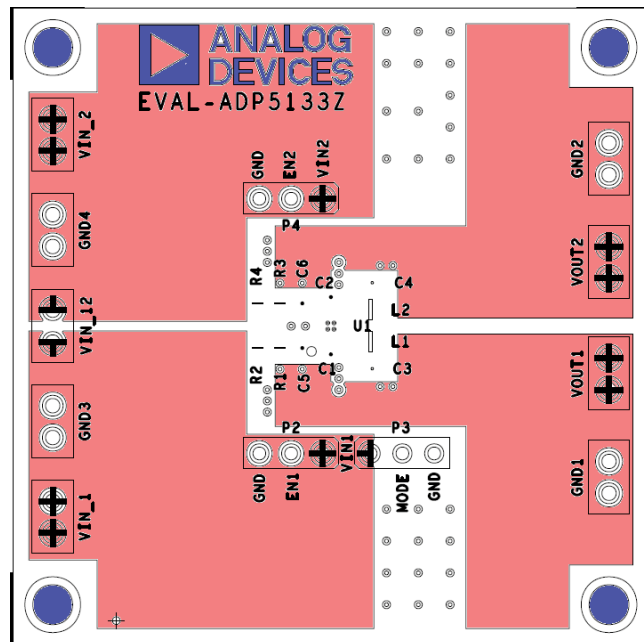

Figure 9. Top Layer, Recommended Layout



11997-010

Figure 10. Second Layer, Recommended Layout



11997-011

Figure 11. Third Layer, Recommended Layout

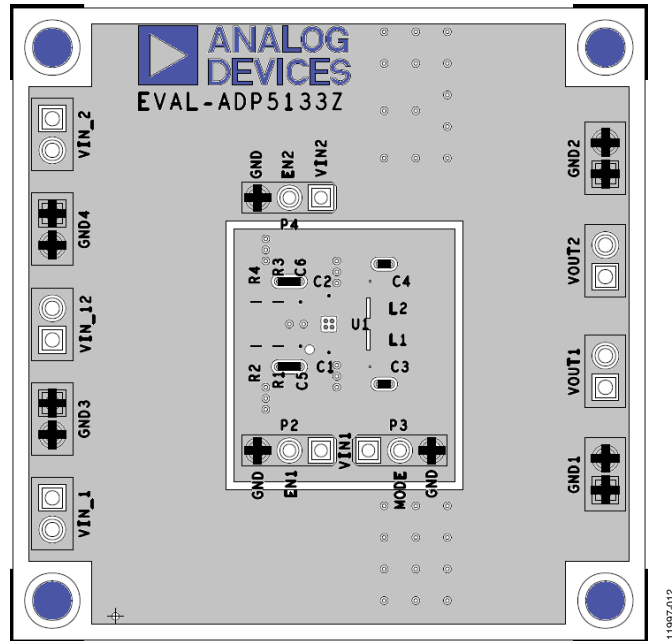

Figure 12. Bottom Layer, Recommended Layout

ORDERING INFORMATION**BILL OF MATERIALS**

Table 2.

Qty	Reference Designator	Description	Manufacturer	Part Number
1	U1	ADP5133 micro PMU, 2 regulators	Analog Devices	ADP5133
2	C1, C2	Capacitor, MLCC, 4.7 μ F, 6.3 V, 0402, X5R	Murata	GRM155R60J475ME87D
2	C3, C4	Capacitor, MLCC, 10.0 μ F, 6.3 V, 0603, X5R	Murata	GRM188R60J106ME47D
2	L1, L2	Inductor, 1.0 μ H, 1.4 A, 85 m Ω	Murata	LQM2MPN1R0NG0
1	R1	Resistor, 0402, 140 k Ω	Panasonic	ERJ-2RKF1403X
1	R2	Resistor, 0402, 100 k Ω	Panasonic	ERJ-2RKF1003X
1	R3	Resistor, 0402, 280 k Ω	Vishay	CRCW0402280KFKED
1	R4	Resistor, 0402, 49.9 k Ω	Panasonic	ERJ-2RKF4992X

NOTES

NOTES

**ESD Caution**

ESD (electrostatic discharge) sensitive device. Charged devices and circuit boards can discharge without detection. Although this product features patented or proprietary protection circuitry, damage may occur on devices subjected to high energy ESD. Therefore, proper ESD precautions should be taken to avoid performance degradation or loss of functionality.

Legal Terms and Conditions

By using the evaluation board discussed herein (together with any tools, components documentation or support materials, the "Evaluation Board"), you are agreeing to be bound by the terms and conditions set forth below ("Agreement") unless you have purchased the Evaluation Board, in which case the Analog Devices Standard Terms and Conditions of Sale shall govern. Do not use the Evaluation Board until you have read and agreed to the Agreement. Your use of the Evaluation Board shall signify your acceptance of the Agreement. This Agreement is made by and between you ("Customer") and Analog Devices, Inc. ("ADI"), with its principal place of business at One Technology Way, Norwood, MA 02062, USA. Subject to the terms and conditions of the Agreement, ADI hereby grants to Customer a free, limited, personal, temporary, non-exclusive, non-sublicensable, non-transferable license to use the Evaluation Board FOR EVALUATION PURPOSES ONLY. Customer understands and agrees that the Evaluation Board is provided for the sole and exclusive purpose referenced above, and agrees not to use the Evaluation Board for any other purpose. Furthermore, the license granted is expressly made subject to the following additional limitations: Customer shall not (i) rent, lease, display, sell, transfer, assign, sublicense, or distribute the Evaluation Board; and (ii) permit any Third Party to access the Evaluation Board. As used herein, the term "Third Party" includes any entity other than ADI, Customer, their employees, affiliates and in-house consultants. The Evaluation Board is NOT sold to Customer; all rights not expressly granted herein, including ownership of the Evaluation Board, are reserved by ADI. CONFIDENTIALITY. This Agreement and the Evaluation Board shall all be considered the confidential and proprietary information of ADI. Customer may not disclose or transfer any portion of the Evaluation Board to any other party for any reason. Upon discontinuation of use of the Evaluation Board or termination of this Agreement, Customer agrees to promptly return the Evaluation Board to ADI. ADDITIONAL RESTRICTIONS. Customer may not disassemble, decompile or reverse engineer chips on the Evaluation Board. Customer shall inform ADI of any occurred damages or any modifications or alterations it makes to the Evaluation Board, including but not limited to soldering or any other activity that affects the material content of the Evaluation Board. Modifications to the Evaluation Board must comply with applicable law, including but not limited to the RoHS Directive. TERMINATION. ADI may terminate this Agreement at any time upon giving written notice to Customer. Customer agrees to return to ADI the Evaluation Board at that time. LIMITATION OF LIABILITY. THE EVALUATION BOARD PROVIDED HEREUNDER IS PROVIDED "AS IS" AND ADI MAKES NO WARRANTIES OR REPRESENTATIONS OF ANY KIND WITH RESPECT TO IT. ADI SPECIFICALLY DISCLAIMS ANY REPRESENTATIONS, ENDORSEMENTS, GUARANTEES, OR WARRANTIES, EXPRESS OR IMPLIED, RELATED TO THE EVALUATION BOARD INCLUDING, BUT NOT LIMITED TO, THE IMPLIED WARRANTY OF MERCHANTABILITY, TITLE, FITNESS FOR A PARTICULAR PURPOSE OR NON-INFRINGEMENT OF INTELLECTUAL PROPERTY RIGHTS. IN NO EVENT WILL ADI AND ITS LICENSORS BE LIABLE FOR ANY INCIDENTAL, SPECIAL, INDIRECT, OR CONSEQUENTIAL DAMAGES RESULTING FROM CUSTOMER'S POSSESSION OR USE OF THE EVALUATION BOARD, INCLUDING BUT NOT LIMITED TO LOST PROFITS, DELAY COSTS, LABOR COSTS OR LOSS OF GOODWILL. ADI'S TOTAL LIABILITY FROM ANY AND ALL CAUSES SHALL BE LIMITED TO THE AMOUNT OF ONE HUNDRED US DOLLARS (\$100.00). EXPORT. Customer agrees that it will not directly or indirectly export the Evaluation Board to another country, and that it will comply with all applicable United States federal laws and regulations relating to exports. GOVERNING LAW. This Agreement shall be governed by and construed in accordance with the substantive laws of the Commonwealth of Massachusetts (excluding conflict of law rules). Any legal action regarding this Agreement will be heard in the state or federal courts having jurisdiction in Suffolk County, Massachusetts, and Customer hereby submits to the personal jurisdiction and venue of such courts. The United Nations Convention on Contracts for the International Sale of Goods shall not apply to this Agreement and is expressly disclaimed.