

Series 90 Connectors

Insert Arrangements

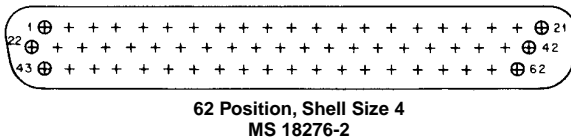
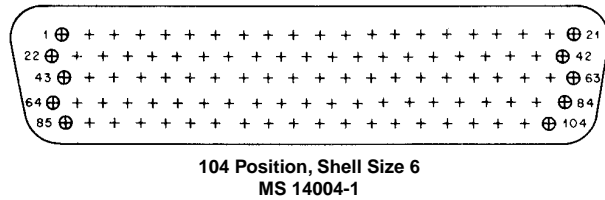
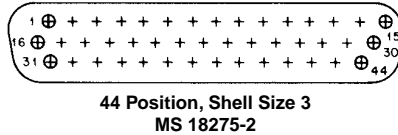
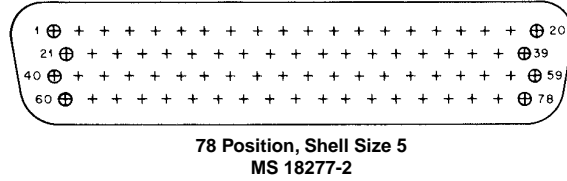
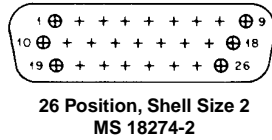
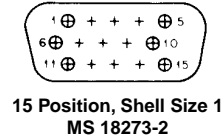

Note: Mating face of plug shown: receptacle is mirror image.

Performance Specifications

All Series 90 AMPLIMITE military connectors conform to the latest amendments of military specification MIL-DTL-24308. For more detailed information, refer to MIL-DTL-24308.

All Series 90 connectors are designed for a -67°F to 257°F [-55°C to +125°C] temperature range.

Technical Documents List

The following is a list of technical documents that cover the application and performance of AMPLIMITE Series 90 military connectors, contacts, tooling and accessories.

Military Specifications

- MIL-DTL-24308 Connectors, Electric, Rectangular, Miniature Polarized Shell, Rack and Panel, General Specifications for
- MIL-C-39029 Contacts, Electrical Connector, General Specification for

NASA Specification

- GSFC-S-311-P-4 Non-Magnetic Connectors, General Specification for

AMP Instruction Sheets

- 408-7516 AMP Application Tooling for MIL-C-39029 Contacts
- 408-7610 Application and Maintenance for AMP Hand Crimping Tool 90294-1
- 408-7508 AMP Insertion/Extraction Tools 91067-1, 91067-2 and 91067-3
- 408-7837 AMP Female Screwlock Kit 205817-8 and AMP Male Screw/Retainer Kit 211883-5

Size 22 Crimp Contacts for Series 90 Connectors (MIL-C-39029)

Size 22 Crimp, Snap-In  
Contacts .030 [0.76]  
Pin Diameter

Material and Finish

**Pin, Socket Body** — Copper alloy, plated gold over nickel underplate  
**Socket Hood** — Passivated stainless steel

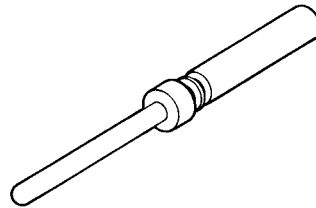

**Pin**  
**M39029/58-360**  
(Supersedes M24308/13-1)

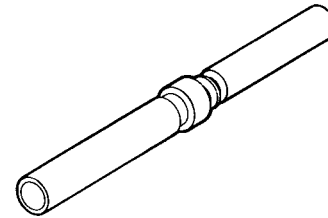

**Socket**  
**M39029/57-354**  
(Supersedes M24308/12-1)

Wire Size Range		Ins. Dia. (Max.)	Contact Configuration	Tape Mounted Contacts <sup>1</sup>		Loose Piece Contacts		Hand Tool		Contact Color Bands
AWG	[mm <sup>2</sup> ]			AMP Part No.	Military Part No. (M39029/)	AMP Part No.	Tool No. (M22520/)	Positioner No. (M22520/)		
22-28	0.4-0.8	.054 1.38	Pin	204370-5	58-360	204370-2	02-01	02-09	orange, blue, black	
			Socket	204351-2	57-354	204351-1	02-01	02-06	orange, green, yellow	

<sup>1</sup>Tape mounted contacts are used in the AMP-TAPEMATIC Stripper/Crimper Machine Part Number **599406-7** (page 5142).

- Notes:**
1. These contacts are used in Series 90 military connectors.
  2. Insertion/Extraction Tool Part Number **91067-1** (Military Part Number **M81969/1-04**) is used to install and remove pin and socket contacts.
  3. See AMP Instruction Sheet 408-7516 for wire length, tool and selector settings.
  4. Color bands are read in the direction of terminal (wire barrel) end to mating end.

Size 22 Crimp Contacts for Series 90 Connectors (Industrial Grade)

Size 22 Crimp, Snap-In  
Contacts .030 [0.76]  
Pin Diameter

Material and Finish

**Pin Body** — Copper alloy with .000050-.000100 [0.00127-0.00254] gold plate over .000050-.000150 [0.00127-0.00381] nickel underplate

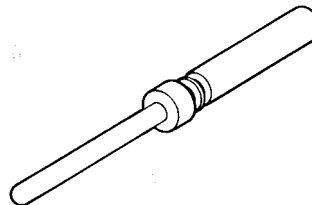

**Pin**

Wire Size Range		Ins. Dia. (Max.)	Contact Configuration	Tape Mounted Contacts <sup>1</sup> Part No.	Loose Piece Contacts Part No.	Hand Tool	
AWG	[mm <sup>2</sup> ]					Tool No. (M22520/)	Positioner No. (M22520/)
22-28	0.4-0.8	.054 1.38	Pin	1218699-2	1218699-1	02-01	02-09
			Socket	—	—	—	—

<sup>1</sup>Tape mounted contacts are used in the AMP-TAPEMATIC Stripper/Crimper Machine Part Number **599406-7** (page 5142).

- Notes:**
1. These contacts are used in Series 90 connectors.
  2. Insertion/Extraction Tool Part Number **91067-1** (Military Part Number **M81969/1-04**) is used to install and remove pin and socket contacts.
  3. See AMP Instruction Sheet 408-7516 for wire length, tool and selector settings.

Size 22 Posted Contacts for Series 90 Connectors

Size 22 Posted Contacts

Material and Finish

**Pin and Socket Body** — Leaded nickel copper or beryllium copper

**Socket Hood** — See chart below



Pin and Socket Insertion/Extraction Tool

AMP Part Number 91067-1 or MIL Part Number M81969/1-04  
 Insertion tip, for replacement Part Number 126237-1  
 Extraction tip, for replacement Part Number 126195-2

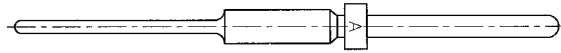

Pin  
 (See drawing No. 207683 for latest configurations)

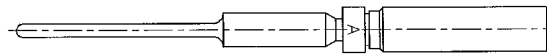

Socket  
 (See drawing No. 207684 for latest configurations)

Notes:

1. Contacts on this page can be used with connectors on pages 5130-5134, 5140. See page 5145 for PCB layouts.
2. Mating End of pin and socket complies with MIL-C-39029.

Post Diameter ± .002 [± .050]	Post Extension C ± .025 [± 0.63]	Part Nos.		Contact Plating	Socket Hood Material and Finish	
		Pin	Socket			
.018 0.46	.175 4.45	207683-6	207684-3	Pin .000050-.000100 [0.00127-0.00254] thick gold plate over	Socket .000050-.000100 [0.00127-0.00254] thick gold plate over	Brass or Beryllium copper with .000050-.000100 [0.00127-0.00254] thick gold plate over .000100-.000250 [0.00254-0.00635] thick copper underplate
	.275 6.99	207683-2	207684-1	.000100-.000150 [0.00254-0.00381] thick copper underplate	.000100-.000250 [0.00254-0.00635] thick copper underplate	
	.525 13.34	207683-4	207684-2			
.025 0.64	.275 6.99	207683-8	207684-4	.000050-.000100 [0.00127-0.00254] thick gold plate over .000050-.000150 [0.00127-0.00381] thick nickel underplate		Passivated Stainless Steel
	.275 6.99	—	207684-5	.000050-.000100 [0.00127-0.00254] thick gold plate over		
.018 0.46	.525 13.34	207683-9	—	.000050-.000150 [0.00127-0.00381] thick nickel underplate		Passivated Stainless Steel
	.175 4.45	1-207683-1	—	.000050-.000100 [0.00127-0.00254] thick gold plate over .000200-.000250 [0.00508-0.00635] thick nickel underplate		

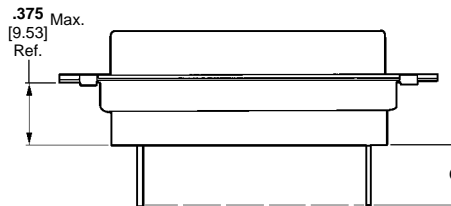

Post extension when used in a standard connector

**(MIL Qualified)**

**Material and Finish**

**Shell** — Steel, cadmium plated

**Insert** — Approved material per MIL-DTL-24308

**Retention Clips** — Stainless steel or copper alloy

**(Industrial Grade)**

**Material and Finish**

**Shell** — Steel, zinc plated

**Insert** — Polyphenylene Sulfide (PPS)

**Retention Clips** — Stainless steel or copper alloy

**Related Product Data**

**Cavity Identification** — page 5127

**Contacts** — pages 5128, 5129

**Mounting, Mating Dimensions** — page 5143

**Accessories** — pages 5148-5150

**Attention: MIL Qualified**

**Connector marking**

Connector marking may differ from package marking. All connectors marked per MIL-DTL-24308.

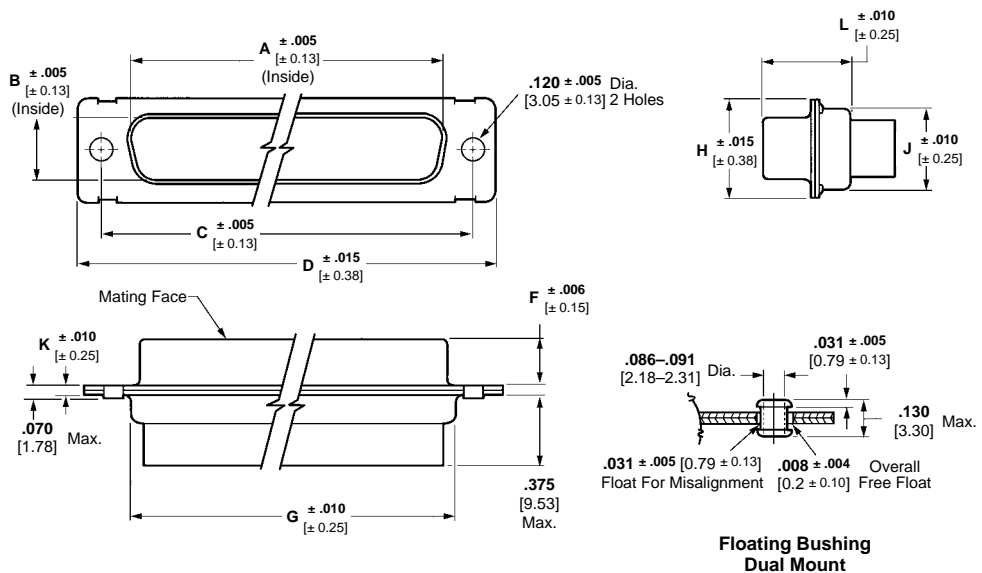

No. of Contact Pos. (Shell Size)	Dimensions											MIL Qualified				Description	Industrial Grade <sup>3</sup> Standard Mount Part No.
	A	B	C	D	F	G	H	J	K	L	Standard Mount		Floating Bushing Mount				
	Military Part No. <sup>2</sup> M24308/	AMP Part No.	Military Part No. M24308/	AMP Part No.													
15 (1)	.666	.329	.984	1.213	.235	.759	.494	.422	.030	.422	4-264F	204501-1	4-329F	204525-1	Plug only	1218746-1	
	16.92	8.36	24.99	30.81	5.97	19.28	12.55	10.72	0.76	10.72	4-11F	204513-2	4-307F	204537-2	Plug with pins <sup>1</sup>	—	
26 (2)	.994	.329	1.312	1.541	.235	1.083	.494	.422	.030	.422	4-265F	204503-1	4-330F	204527-1	Plug only	1218746-2	
	25.25	8.36	33.32	39.14	5.97	27.51	12.55	10.72	0.76	10.72	4-12F	204515-2	4-308F	204539-2	Plug with pins <sup>1</sup>	—	
44 (3)	1.534	.329	1.852	2.088	.230	1.625	.494	.422	.039	.426	4-266F	204505-1	4-331F	204529-1	Plug only	1218746-3	
	38.96	8.36	47.04	53.04	5.84	4.13	12.55	10.72	0.99	10.82	4-13F	204517-2	4-309F	204541-2	Plug with pins <sup>1</sup>	—	
62 (4)	2.182	.329	2.500	2.729	.230	2.272	.494	.422	.039	.426	4-267F	204507-1	4-332F	204531-1	Plug only	1218746-4	
	55.42	8.36	63.5	69.32	5.84	57.7	12.55	10.72	0.99	10.82	4-14F	204519-2	4-310F	204543-2	Plug with pins <sup>1</sup>	—	
78 (5)	2.079	.441	2.406	2.635	.230	2.178	.605	.534	.039	.426	4-268F	204509-1	4-333F	204533-1	Plug only	1218746-5	
	52.81	11.2	61.11	66.93	5.84	55.32	15.37	13.56	0.99	10.82	4-15F	204521-2	4-311F	204545-2	Plug with pins <sup>1</sup>	—	
104 (6)	2.212	.503	2.500	2.729	.230	2.302	.668	.596	.039	.426	4-269F	204511-1	4-334F	204535-1	Plug only	1218746-6	
	56.18	12.78	63.5	69.32	5.84	58.47	16.97	15.14	0.99	10.82	4-16F	204523-2	4-312F	204547-2	Plug with pins <sup>1</sup>	—	

**Notes:** See pages 5151 through 5155 (military to AMP Part Number cross reference) for additional part numbers.  
<sup>1</sup> Size 22 sockets supplied with receptacles are loose piece.  
<sup>2</sup> "F" is stamped on connectors following M24308 part number as required. "F" designates cadmium shell plating.  
<sup>3</sup> Meets requirements of MIL-DTL-24308.

Crimp Receptacles, Series 90, High Density Connectors

**(MIL Qualified)**

**Material and Finish**

**Shell** — Steel, cadmium plated

**Insert** — Approved material per MIL-DTL-24308

**Retention Clips** — Stainless steel or copper alloy

**(Industrial Grade)**

**Material and Finish**

**Shell** — Steel, zinc plated

**Insert** — Polyphenylene Sulfide (PPS)

**Retention Clips** — Stainless steel or copper alloy

**Related Product Data**

**Cavity Identification** — page 5127

**Contacts** — pages 5128, 5129

**Mounting, Mating Dimensions** — page 5143

**Accessories** — pages 5148-5150

**Attention: Connector marking**

Connector marking may differ from package marking. All connectors marked per MIL-DTL-24308.

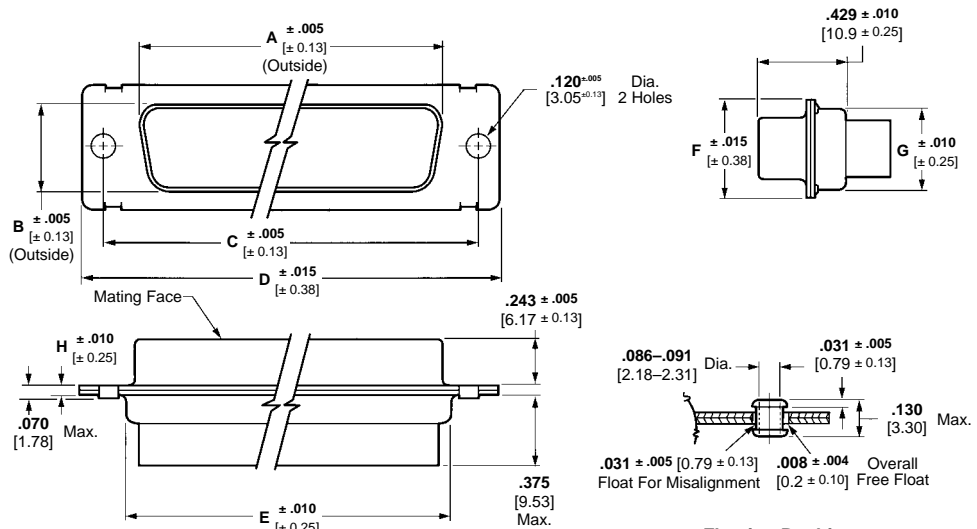

**Floating Bushing Dual Mount**



**Clinch Nut Mount**

No. of Contact Pos. (Shell Size)	Dimensions								MIL Qualified				Description	Industrial Grade <sup>3</sup> Clinch Nut Mount Part No.
	A	B	C	D	E	F	G	H	Standard Mount		Floating Bushing Mount			
	Military Part No. <sup>2</sup> M24308/	AMP Part No.	Military Part No. <sup>2</sup> M24308/	AMP Part No.	Military Part No. <sup>2</sup> M24308/	AMP Part No.	Military Part No. <sup>2</sup> M24308/	AMP Part No.	Military Part No. <sup>2</sup> M24308/	AMP Part No.	Military Part No. <sup>2</sup> M24308/	AMP Part No.		
15 (1)	.643 [16.33]	.311 [7.9]	.984 [24.99]	1.213 [30.81]	.759 [19.28]	.494 [12.55]	.422 [10.72]	.030 [0.76]	2-286F	204500-1	2-297F	204524-1	Recept. only	1218747-1
26 (2)	.971 [24.66]	.311 [7.9]	1.312 [33.32]	1.541 [39.14]	1.083 [27.51]	.494 [12.55]	.422 [10.72]	.030 [0.76]	2-287F	204502-1	2-298F	204526-1	Recept. only	1218747-2
44 (3)	1.511 [38.38]	.311 [7.9]	1.852 [47.04]	2.088 [53.04]	1.625 [41.3]	.494 [12.55]	.422 [10.72]	.039 [0.99]	2-288F	204504-1	2-299F	204528-1	Recept. only	1218747-3
62 (4)	2.159 [54.84]	.311 [7.9]	2.500 [63.5]	2.729 [69.32]	2.272 [57.7]	.494 [12.55]	.422 [10.72]	.039 [0.99]	2-289F	204506-1	2-300F	204530-1	Recept. only	1218747-4
78 (5)	2.064 [52.43]	.423 [10.74]	2.406 [61.11]	2.635 [66.93]	2.178 [55.32]	.605 [15.37]	.534 [13.56]	.039 [0.99]	2-290F	204508-1	2-301F	204532-1	Recept. only	1218747-5
104 (6)	2.189 [55.6]	.485 [12.32]	2.500 [63.5]	2.729 [69.32]	2.302 [58.47]	.668 [16.97]	.596 [15.14]	.039 [0.99]	2-291F	204510-1	2-302F	204534-1	Recept. only	1218747-6
									2-16F	204522-2	2-33F	204546-2	Recept. with sockets <sup>1</sup>	—

**Notes:** See pages 5151 through 5155 (military to AMP Part Number cross reference) for additional part numbers.

<sup>1</sup> Size 22 sockets supplied with receptacles are loose piece.

<sup>2</sup> "F" is stamped on connectors following M24308 part number as required. "F" designates cadmium shell plating.

<sup>3</sup> Meets requirements of MIL-DTL-24308.

**Non-Magnetic Crimp Plugs, Series 90, High Density Connectors (NASA Qualified)**

**Connector Material and Finish**

**Shell** — Brass, gold plated

**Insert** — Approved material per MIL-DTL-24308

**Retention Clips** — Copper alloy

**Related Product Data**

Cavity Identification — page 5127

**Mounting, Mating Specifications** — page 5143

**Accessories** — pages 5148-5150

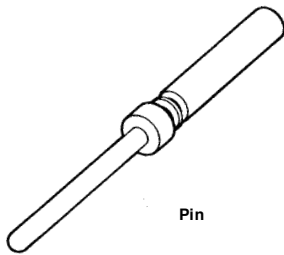
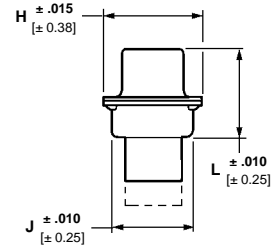
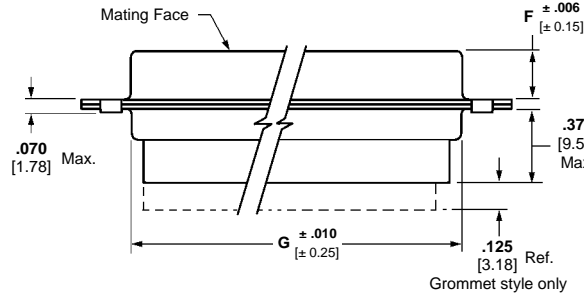
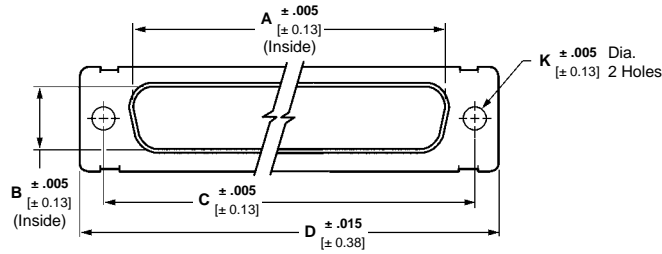

Pin

Wire Size Range	AMP Part No. / NASA No.
22-28 0.4-0.08	204370-8 G-08-P1
26-28 0.15-0.08	206495-3 —

Max. insulation diameter .054 [1.38]

Hand tool AMP Part Number 601966-1 or MIL Part Number M22520/2-01

Positioner AMP Part Number 601966-6 or MIL Part Number M22520/2-09

**Contact Material and Finish**

Copper alloy, .000050-.000100 [0.00127-0.0254] thick gold plate over .000100-.000150 [0.0254-0.00381] thick copper underplate

**Non-Magnetic Plugs per NASA Specification**

No. of Contact Pos. (Shell Size)	Dimensions										NASA No.	AMP Part No.	
	A	B	C	D	F	G	H	J	L	K			
15 (1)	.666 16.92	.329 8.36	.984 24.99	1.213 30.81	.235 5.97	.759 19.28	.494 12.55	.422 10.72	.422 10.72	.154 3.91	.120 3.05	311P407-1P-B-15	206498-1
26 (2)	.994 25.25	.329 8.36	1.312 33.32	1.541 39.14	.235 5.97	1.083 27.51	.494 12.55	.422 10.72	.422 10.72	.154 3.91	.120 3.05	311P407-2P-B-15 311P407-2P-B-12	206500-1 206500-4
44 (3)	1.534 38.96	.329 8.36	1.852 47.04	2.088 53.04	.230 5.84	1.625 41.3	.494 12.55	.422 10.72	.426 10.82	.154 3.91	.120 3.05	311P407-3P-B-15 311P407-3P-B-12	206063-2 206063-4
62 (4)	2.182 55.42	.329 8.36	2.500 63.5	2.729 69.32	.230 5.84	2.272 57.7	.494 12.55	.422 10.72	.426 10.82	.154 3.91	.120 3.05	311P407-4P-B-15 311P407-4P-B-12	206502-1 206502-4
78 (5)	2.079 52.81	.441 11.20	2.406 61.11	2.635 66.93	.230 5.84	2.178 57.7	.605 15.37	.534 13.56	.426 10.82	.154 3.91	.120 3.05	311P407-5P-B-15 311P407-5P-B-12	206504-1 206504-4
104 (6)	2.212 56.18	.503 12.78	2.500 63.5	2.729 69.32	.230 5.84	2.302 58.47	.668 16.97	.596 15.14	.426 10.82	.154 3.91	.120 3.05	311P407-6P-B-15 311P407-6P-B-12	206066-2 206066-4

**Non-Magnetic Plugs With Silicone Rubber Rear Grommet<sup>1</sup>**

No. of Contact Pos. (Shell Size)	Dimensions										AMP Part No.	
	A	B	C	D	F	G	H	J	K	L		
15 (1)	.666 16.92	.329 8.36	.984 24.99	1.213 30.81	.235 5.97	.759 19.28	.494 12.55	.422 10.72	.422 10.72	.120 3.05	.422 10.72	211673-4
26 (2)	.994 25.25	.329 8.36	1.312 33.32	1.541 39.14	.235 5.97	1.083 27.51	.494 12.55	.422 10.72	.422 10.72	.120 3.05	.422 10.72	211674-4
44 (3)	1.534 38.96	.329 8.36	1.852 47.04	2.088 53.04	.230 5.84	1.625 41.3	.494 12.55	.422 10.72	.426 10.82	.120 3.05	.426 10.82	211675-4
62 (4)	2.182 55.42	.329 8.36	2.500 63.5	2.729 69.32	.230 5.84	2.272 57.7	.494 12.55	.422 10.72	.426 10.82	.120 3.05	.426 10.82	211676-4
78 (5)	2.079 52.81	.441 11.20	2.406 61.11	2.635 66.93	.230 5.84	2.178 55.32	.605 15.37	.534 13.56	.426 10.82	.120 3.05	.426 10.82	211677-4
104 (6)	2.212 56.18	.503 12.78	2.500 63.5	2.729 69.32	.230 5.84	2.302 58.47	.668 16.97	.596 15.14	.426 10.82	.120 3.05	.426 10.82	211678-4

<sup>1</sup> Grommet provided for cable strain relief.



Pin and Socket Insertion/Extraction Tool

AMP Part Number 91067-1 or MIL Part Number M81969/1-04

Insertion tip, for replacement Part Number 126237-1

Extraction tip, for replacement Part Number 126195-2

**Non-Magnetic Crimp Receptacles, Series 90, High Density Connectors (NASA Qualified)**

**Connector Material and Finish**

**Shell** — Brass, gold plated

**Insert** — Approved material per MIL-DTL-24308

**Retention Clips** — Copper alloy

**Related Product Data**

**Cavity Identification** — page 5127

**Mounting, Mating Specifications** — page 5143

**Accessories** — pages 5148-5150

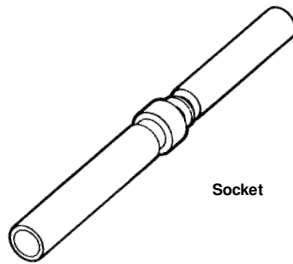
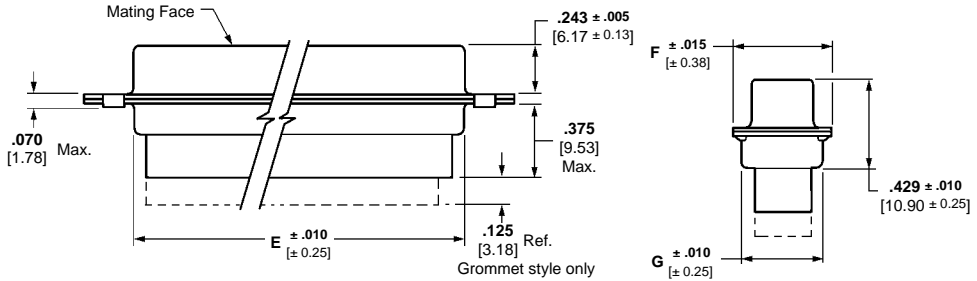
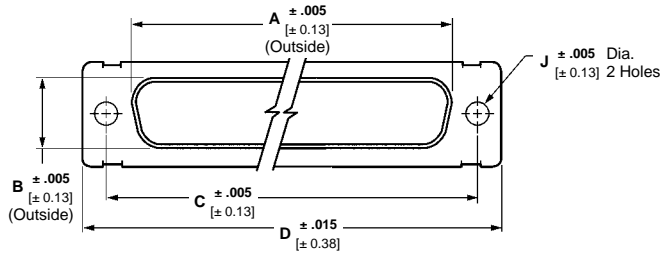

Socket

Wire Size Range	AMP Part No. / NASA No.
22-28 0.4-0.08	206071-1 G-08-S1
26-28 0.15-0.08	206496-1 —

Max. insulation diameter .054 [1.38]  
Hand tool AMP Part Number 601966-1 or MIL Part Number M22520/2-01  
Positioner AMP Part Number 601966-4 or MIL Part Number M22520/2-06

**Contact and Hood Material and Finish**

Copper alloy, .000050–.000100 [0.00127–0.0254] thick gold plate over .000100–.000150 [0.0254–0.00381] thick copper underplate

**Non-Magnetic Receptacles per NASA Specification**

No. of Contact Pos. (Shell Size)	Dimensions									NASA No.	AMP Part No.
	A	B	C	D	E	F	G	J			
15 (1)	.643	.311	.984	1.213	.759	.494	.422	.154	3.91	311P407-1S-B-15	206499-1
	16.33	7.9	24.99	30.81	19.28	12.55	10.72	.120	3.05		
26 (2)	.971	.311	1.312	1.541	1.083	.494	.422	.154	3.91	311P407-2S-B-15	206501-1
	24.66	7.9	33.32	39.14	27.51	12.55	10.72	.120	3.05		
44 (3)	1.511	.311	1.852	2.088	1.625	.494	.422	.154	3.91	311P407-3S-B-15	206064-2
	38.38	7.9	47.04	53.04	41.3	12.55	10.72	.120	3.05		
62 (4)	2.159	.311	2.500	2.729	2.272	.494	.422	.154	3.91	311P407-4S-B-15	206503-1
	54.84	7.9	63.5	69.32	57.7	12.55	10.72	.120	3.05		
78 (5)	2.064	.423	2.406	2.635	2.178	.605	.534	.154	3.91	311P407-5S-B-15	206505-1
	52.43	10.74	61.11	66.93	55.32	15.37	13.56	.120	3.05		
104 (6)	2.189	.485	2.500	2.729	2.302	.668	.596	.154	3.91	311P407-6S-B-15	206065-2
	55.6	12.32	63.5	69.32	58.47	16.97	15.14	.120	3.05		

**Non-Magnetic Receptacles With Silicone Rubber Rear Grommet<sup>1</sup>**



Pin and Socket Insertion/Extraction Tool

AMP Part Number 91067-1 or MIL Part Number M81969/1-04  
Insertion tip, for replacement Part Number 126237-1  
Extraction tip, for replacement Part Number 126195-2

No. of Contact Pos. (Shell Size)	Dimensions									AMP Part No.
	A	B	C	D	E	F	G	J		
15 (1)	.643	.311	.984	1.213	.759	.494	.422	.120	3.05	211667-4
16.33	7.9	24.99	30.81	19.28	12.55	10.72	3.05			
26 (2)	.971	.311	1.312	1.541	1.083	.494	.422	.120	3.05	211668-4
24.66	7.9	33.32	39.14	27.51	12.55	10.72	3.05			
44 (3)	1.511	.311	1.852	2.088	1.625	.494	.422	.120	3.05	211669-4
38.38	7.9	47.04	53.04	41.3	12.55	10.72	3.05			
62 (4)	2.159	.311	2.500	2.729	2.272	.494	.422	.120	3.05	211670-4
54.84	7.9	63.5	69.32	57.7	12.55	10.72	3.05			
78 (5)	2.064	.423	2.406	2.635	2.178	.605	.534	.120	3.05	211671-4
52.43	10.74	61.11	66.93	55.32	15.37	13.56	3.05			
104 (6)	2.189	.485	2.500	2.729	2.302	.668	.596	.120	3.05	211672-4
55.6	12.32	63.5	69.32	58.47	16.97	15.14	3.05			

<sup>1</sup> Grommet provided for cable strain relief.

Crimp Blindmate Plugs, Series 90, High Density Connectors

**Material and Finish**

**Shell, Front** — Aluminum alloy, cadmium plated with yellow chromate

**Shell, Rear** — Steel, cadmium plated with yellow chromate

**Insert Assembly** — Approved material per MIL-DTL-24308

**Retention Clips** — Stainless steel

**Related Product Data**

**Cavity Identification** — page 5127

**Contacts** — pages 5128, 5129

**Mounting Specifications** — page 5143

Flange to flange spacing can be a max. of .270 [6.86] for Blindmate connectors.

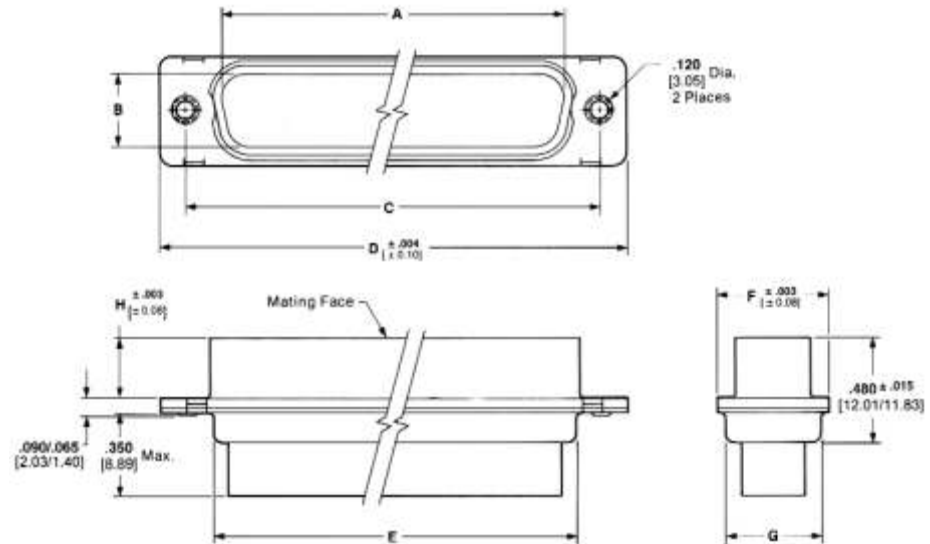

No. of Contact Pos. (Shell Size)	Dimensions								AMP Part No.
	A	B	C	D	E	F	G	H	
15 (1)	.656 16.66	.324 8.23	.984 24.99	1.224 31.09	.769/.750 19.53/19.05	.506 12.85	.432/.413 10.97/10.49	.257 6.53	213153-1
26 (2)	.984 25.0	.324 8.23	1.312 33.32	1.552 39.42	1.093/1.074 27.76/27.28	.506 12.85	.432/.413 10.97/10.49	.257 6.53	445010-1
44 (3)	1.524 38.71	.324 8.23	1.852 47.04	2.099 53.31	1.635/1.616 41.53/41.05	.506 12.85	.432/.413 10.97/10.49	.257 6.53	445011-1
62 (4)	2.172 55.17	.324 8.23	2.500 63.5	2.740 69.6	2.282/2.263 57.96/57.48	.506 12.85	.432/.413 10.97/10.49	.257 6.53	213118-1
78 (5)	2.082 52.88	.444 11.28	2.406 61.11	2.646 67.21	2.188/2.167 55.58/55.04	.617 15.67	.544/.525 13.82/13.34	.257 6.53	445012-1
104 (6)	2.212 56.18	.503 12.78	2.500 63.5	2.740 69.6	2.302 58.47	.680 17.27	.606/.587 15.39/14.91	.267 6.78	212933-3



Straight PCB, Series 90, High Density Connectors (Industrial Grade)

**Material and Finish**

- Shell — Steel, cadmium plated
- Insert — Polyphenylene Sulfide (PPS)
- Retention Clips — Stainless steel

**Related Product Data**

- Cavity Identification — page 5127
- Contacts — page 5129
- Mounting, Mating Dimensions — page 5143
- Accessories — pages 5148-5150
- PCB Layouts — See page 5145 or AMP customer drawing

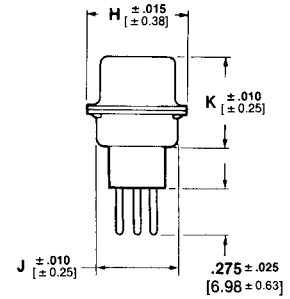
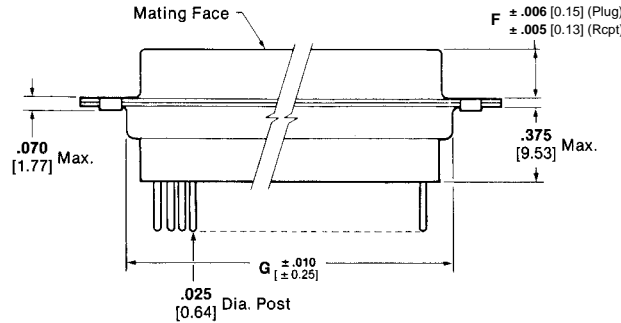
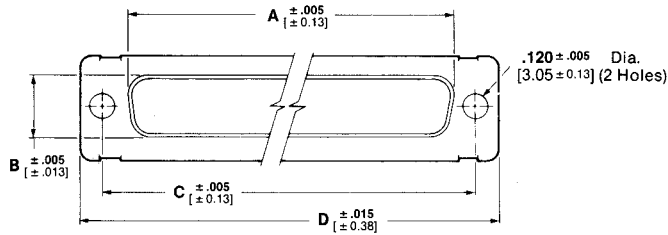

Replacement Pin Contact  
Part Number 207683-8

**Plugs**

No. of Contact Pos. (Shell Size)	Dimensions									AMP Part No.
	A (Inside)	B (Inside)	C	D	F	G	H	J	K	
15 (1)	.666 16.92	.329 8.36	.984 24.99	1.213 30.81	.235 5.97	.759 19.28	.494 12.55	.422 10.72	.422 10.72	208866-1
26 (2)	.994 25.25	.329 8.36	1.312 33.32	1.541 39.14	.235 5.97	1.083 27.51	.494 12.55	.422 10.72	.422 10.72	208867-1
44 (3)	1.534 38.96	.329 8.36	1.852 47.04	2.088 53.04	.230 5.84	1.625 41.3	.494 12.55	.422 10.72	.426 10.82	208868-1
62 (4)	2.182 55.42	.329 8.36	2.500 63.5	2.729 69.32	.230 5.84	2.272 57.7	.494 12.55	.422 10.72	.426 10.82	208869-1
78 (5)	2.079 52.81	.441 11.20	2.406 61.11	2.635 66.93	.230 5.84	2.178 55.32	.605 15.37	.534 13.56	.426 10.82	208870-1
104 (6)	2.212 56.18	.503 12.78	2.500 63.5	2.729 69.32	.230 5.84	2.302 58.47	.668 16.97	.596 15.14	.426 10.82	208871-1

Replacement Socket Contact  
Part Number 207684-4

**Receptacles**

No. of Contact Pos. (Shell Size)	Dimensions									AMP Part No.
	A (Outside)	B (Outside)	C	D	F	G	H	J	K	
15 (1)	.643 16.33	.311 7.9	.984 24.99	1.213 30.81	.243 6.17	.759 19.28	.494 12.55	.422 10.72	.429 10.9	208872-1
26 (2)	.971 24.66	.311 7.9	1.312 33.32	1.541 39.14	.243 6.17	1.083 27.51	.494 12.55	.422 10.72	.429 10.9	208873-1
44 (3)	1.511 38.38	.311 7.9	1.852 47.04	2.088 53.04	.243 6.17	1.625 41.3	.494 12.55	.422 10.72	.429 10.9	208874-1
62 (4)	2.159 54.84	.311 7.9	2.500 63.5	2.729 69.32	.243 6.17	2.272 57.7	.494 12.55	.422 10.72	.429 10.9	208875-1
78 (5)	2.064 52.43	.423 10.74	2.406 61.11	2.635 66.93	.243 6.17	2.178 55.32	.605 15.37	.534 13.56	.429 10.9	208876-1
104 (6)	2.189 55.6	.485 12.32	2.500 63.5	2.729 69.32	.243 6.17	2.302 58.47	.668 16.97	.596 15.14	.429 10.9	208877-1

Right-Angle PCB, Series 90, with Female Screwlocks

**Material and Finish**

**Shell** — Brass, gold over copper plated

**Insert** — Diallyl phthalate or polyester or Polyphenylene Sulfide (PPS)

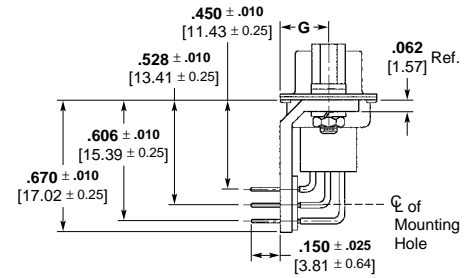
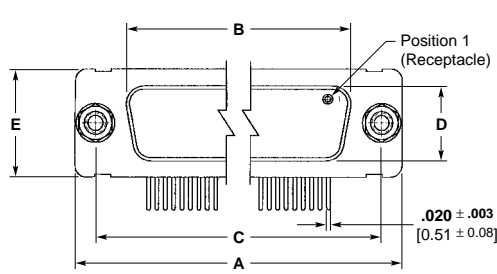

Shell Size 1 thru 4

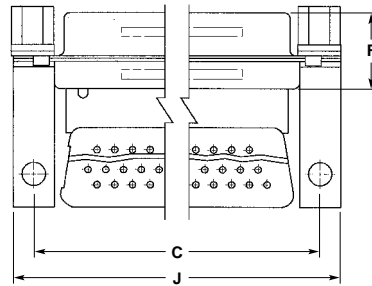

**Plugs**

No. of Contact Pos. (Shell Size)	Dimensions									AMP Part No.
	A	B	C	D	E	F	G	J		
15 (1)	1.213 30.81	.666 16.92	.984 24.99	.329 8.36	.494 12.55	.422 10.72	.246 ± .010 6.25 ± 0.25	1.204 30.58		1-593326-7
26 (2)	1.541 39.14	.994 25.25	1.312 33.32	.329 8.36	.494 12.55	.422 10.72	.246 ± .010 6.25 ± 0.25	1.532 38.91		1-593326-8
44 (3)	2.088 53.04	1.534 38.96	1.852 47.04	.329 8.36	.494 12.55	.426 10.82	.246 ± .010 6.25 ± 0.25	2.077 52.76		1-593326-9
62 (4)	2.729 69.32	2.182 55.42	2.500 63.50	.329 8.36	.494 12.55	.426 10.82	.246 ± .010 6.25 ± 0.25	2.720 69.09		2-593326-0
78 (5)	2.635 66.93	2.079 52.81	2.406 61.11	.441 11.20	.605 15.37	.426 10.82	.246 ± .010 6.25 ± 0.25	2.626 66.70		2-593326-1
104 (6)	2.729 69.32	2.213 56.21	2.500 63.50	.503 12.78	.668 16.97	.426 10.82	.246 ± .010 6.25 ± 0.25	2.720 69.09		2-593326-2

**Receptacles**

No. of Contact Pos. (Shell Size)	Dimensions									AMP Part No.
	A	B	C	D	E	F	G	J		
15 (1)	1.213 30.81	.643 16.33	.984 24.99	.311 7.90	.494 12.55	.422 10.72	.248 ± .010 6.30 ± 0.25	1.204 30.58		1-593327-7
26 (2)	1.541 39.14	.971 24.66	1.312 33.32	.311 7.90	.494 12.55	.422 10.72	.248 ± .010 6.30 ± 0.25	1.532 38.91		1-593327-8
44 (3)	2.088 53.04	1.511 38.38	1.852 47.04	.311 7.90	.494 12.55	.426 10.82	.248 ± .010 6.30 ± 0.25	2.077 52.76		1-593327-9
62 (4)	2.729 69.32	2.159 54.84	2.500 63.50	.311 7.90	.494 12.55	.426 10.82	.248 ± .010 6.30 ± 0.25	2.720 69.09		2-593327-0
78 (5)	2.635 66.93	2.064 52.43	2.406 61.11	.423 10.74	.605 15.37	.426 10.82	.248 ± .010 6.30 ± 0.25	2.626 66.70		2-593327-1
104 (6)	2.729 69.32	2.188 55.58	2.500 63.50	.485 12.32	.668 16.97	.426 10.82	.248 ± .010 6.30 ± 0.25	2.726 69.24		2-593327-2

Connector Savers, Series 90, High Density Connectors

Connector savers prolong the life of permanently installed connectors which would otherwise be subjected to repeated cycles of mating and unmating, in applications such as test interfaces or on testing devices.

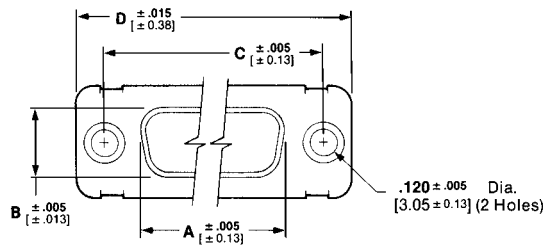

**Material and Finish**

**Standard**

- Shell** — Steel, cadmium plated
- Contact Body** — Beryllium copper, .000050 [0.00127] min. gold plate over .000050 [0.00127] min. nickel underplate
- Socket Hood** — Passivated stainless steel
- Insert** — Polyphenylene Sulfide (PPS)
- Spacer** — Black nylon

**Non Magnetic**

- Shell** — Brass, gold plated
- Contact Body** — Beryllium copper, .000050 [0.00127] min. gold plate over .000050 [0.00127] min. copper underplate
- Socket Hood** — Brass, .000050 [0.00127] min. gold plate over .000100 [0.00254] min. copper underplate
- Insert** — Polyphenylene Sulfide (PPS)
- Spacer** — Black nylon

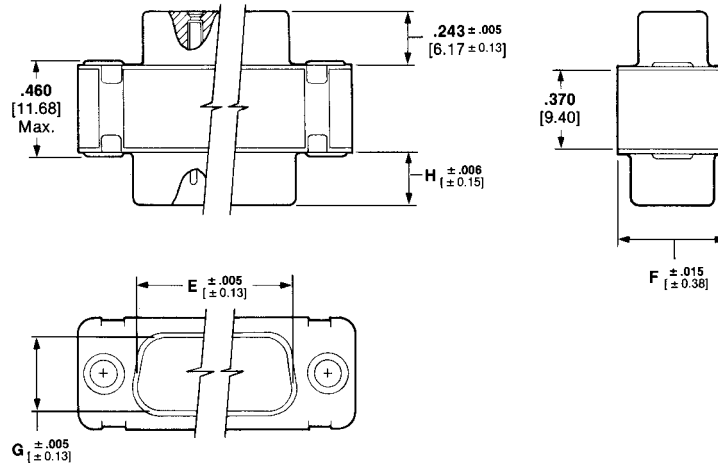

Dimensions							
A (Outside)	B (Outside)	C	D	E (Inside)	F	G (Inside)	H
.643 16.33	.311 7.9	.984 24.99	1.213 30.81	.666 16.92	.494 12.55	.329 8.36	.235 5.97
.971 24.66	.311 7.9	1.312 33.32	1.541 39.14	.994 25.25	.494 12.55	.329 8.36	.235 5.97
1.511 38.38	.311 7.9	1.852 47.04	2.088 53.04	1.534 38.96	.494 12.55	.329 8.36	.230 5.84
2.159 54.84	.311 7.9	2.500 63.5	2.729 69.32	2.182 55.42	.494 12.55	.329 8.36	.230 5.84
2.064 52.43	.423 10.74	2.406 61.11	2.635 66.93	2.079 52.81	.605 15.37	.441 11.20	.230 5.84
2.189 55.60	.485 12.32	2.500 63.5	2.729 69.32	2.212 56.18	.668 16.97	.503 12.78	.230 5.84

No. of Contact Pos. (Shell Size)	Standard (Cadmium Over Steel)	Non-Magnetic (Gold Over Brass)
15 (1)	211010-1	211010-4
26 (2)	211011-1	211011-4
44 (3)	211012-1	211012-4
62 (4)	211013-1	211013-4
78 (5)	211014-1	211014-4
104 (6)	211015-1	211015-4