

THIS DRAWING IS UNPUBLISHED. RELEASED FOR PUBLICATION
 © COPYRIGHT - By - ALL RIGHTS RESERVED.

LOC	DIST	REVISIONS					
		P	LTR	DESCRIPTION	DATE	DWN	APVD
G	14		L1	REVISED PER ECO-11-004917	11MAR11	RK	HMR

AMP WIRE RANGE	Listed FILE E13288	LR7189 Certified
16-14 TO 22-18 AWG STRANDED	16-14 TO 22-18 AWG STRANDED	16-14 TO 22-18 AWG STRANDED

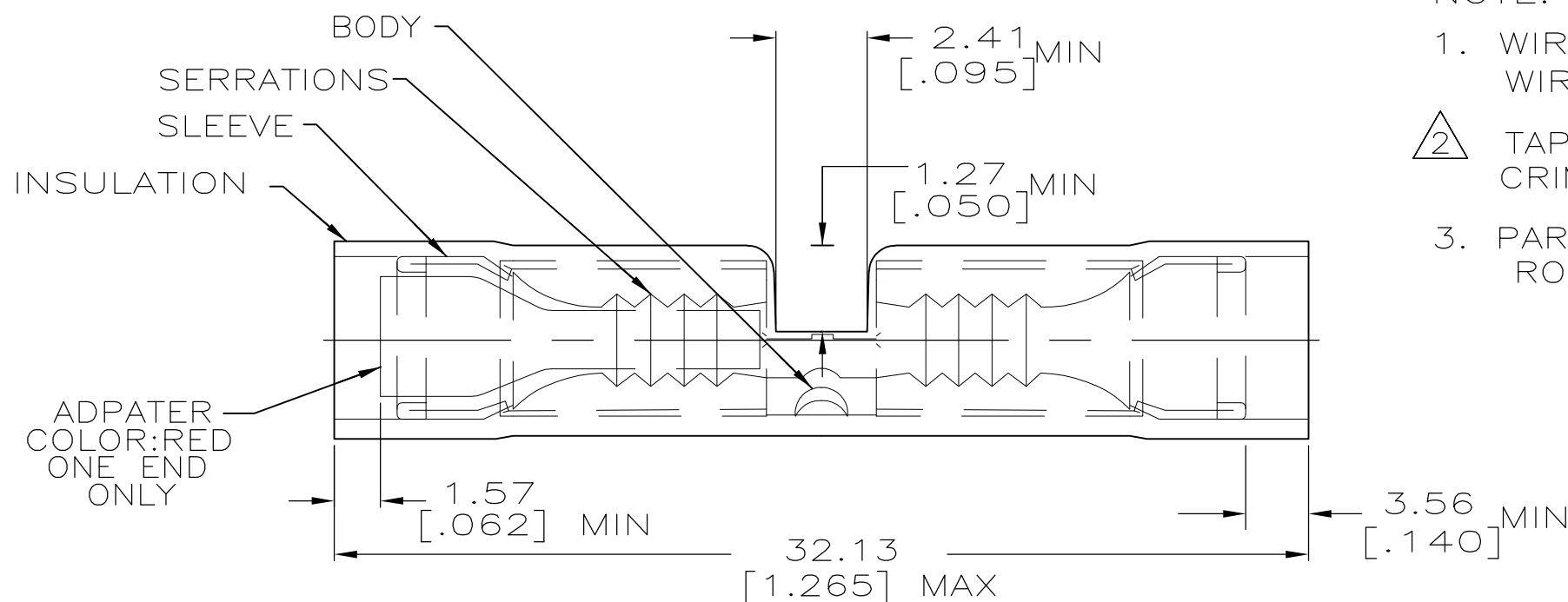

- NOTE:
1. WIRE INSULATION DIA 2.67[.105] TO 3.81[.150]
WIRE INSULATION DIA 1.27[.050] TO 2.92[.115]
 2. TAPE APPLIED TO PART SUCH THAT ADAPTER END IS CRIMPED IN APPLICATOR
 3. PARTS MANUFACTURED AFTER MAY 2005 ARE ROHS COMPLIANT.

2500	ON TAPE	2-327583-1
50	LOOSE PIECE	327583
QTY	PACKAGE TYPE	PART NUMBER

AMP INCORPORATED CUSTOMER SERVICE SYSTEMS		MAX RECOMMENDED OPERATING TEMPERATURE: 105° C	THIS DRAWING IS A CONTROLLED DOCUMENT.		DWN S.S. GOULDEN 9-28-93	TE Connectivity			
FOR ADDITIONAL PRODUCT INFORMATION OR COPIES OF DRAWINGS AND TECHNICAL DOCUMENTS	PRODUCT INFORMATION CENTER 1-800-522-6752	VOLTAGE RATING: 300V MAX	DIMENSIONS: INCHES	TOLERANCES UNLESS OTHERWISE SPECIFIED:	CHK R. HERSEY 9-28-93				NAME SPLICE, BUTT, P.I.D.G., WIRE SIZE: 16-14 TO 22-18 AWG
FOR APPLICATION TOOLING INFORMATION	TOOLING ASSISTANCE CENTER 1-800-722-1111	CIRCULAR MIL AREA: 1.04-2.62mm ² [2,050-5,180] 0.26-0.96mm ² [509-1,900] STRANDED		0 PLC ± - 1 PLC ± - 2 PLC ± 0.20[.008] 3 PLC ± - 4 PLC ± - ANGLES ± -	APVD T. MICHELUTTI 9-28-93	APPLICATION SPEC			
FOR ORDER ENTRY	1-800-526-5142	THIS DRAWING IS A CONTROLLED DOCUMENT FOR AMP INCORPORATED. IT IS SUBJECT TO CHANGE AND THE CONTROLLING ENGINEERING ORGANIZATION SHOULD BE CONTACTED FOR THE LATEST REVISION.	MATERIAL COPPER ASTM B-152	FINISH TIN PLATE	PRODUCT SPEC	SIZE	CAGE CODE	DRAWING NO	RESTRICTED TO
			CUSTOMER DRAWING		WEIGHT	A3	00779	C-327583	
					SCALE		1:1	SHEET	1 OF 1
								REV	L1