

Verpackt im Gurt in Anlehnung an DIN IEC 60286-3  
 tape on reel packaging according to DIN IEC 60286-3  
 Verpackungseinheit: 250 Stück  
 packaging unit: 250 pcs

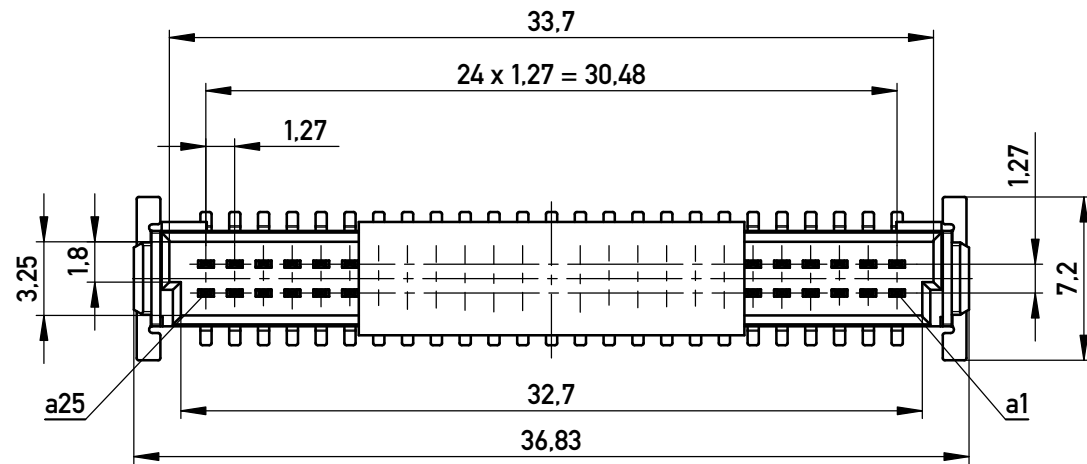
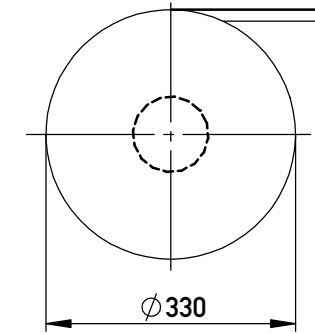

Anforderungsstufe 1  
 performance level 1

Kontaktbereich vergoldet  
 mating area gold plating

Anschlussbereich verzinkt 4-6 µm  
 terminal area 4-6 µm tin plating

Koplanarität der Anschlüsse ≤ 0,1 mm  
 coplanarity area of termination ≤ 0,1 mm

Abspulrichtung - Reel off Direction

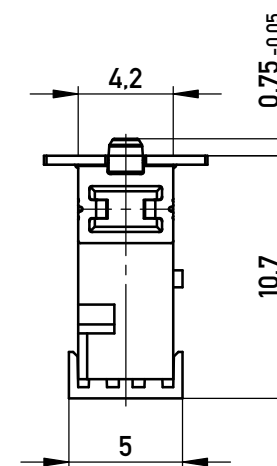
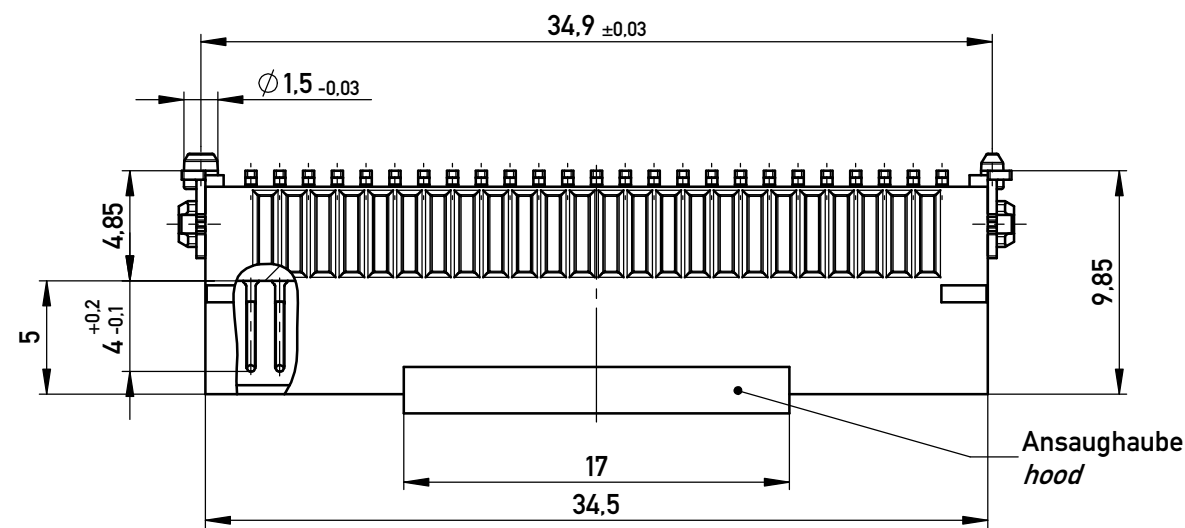
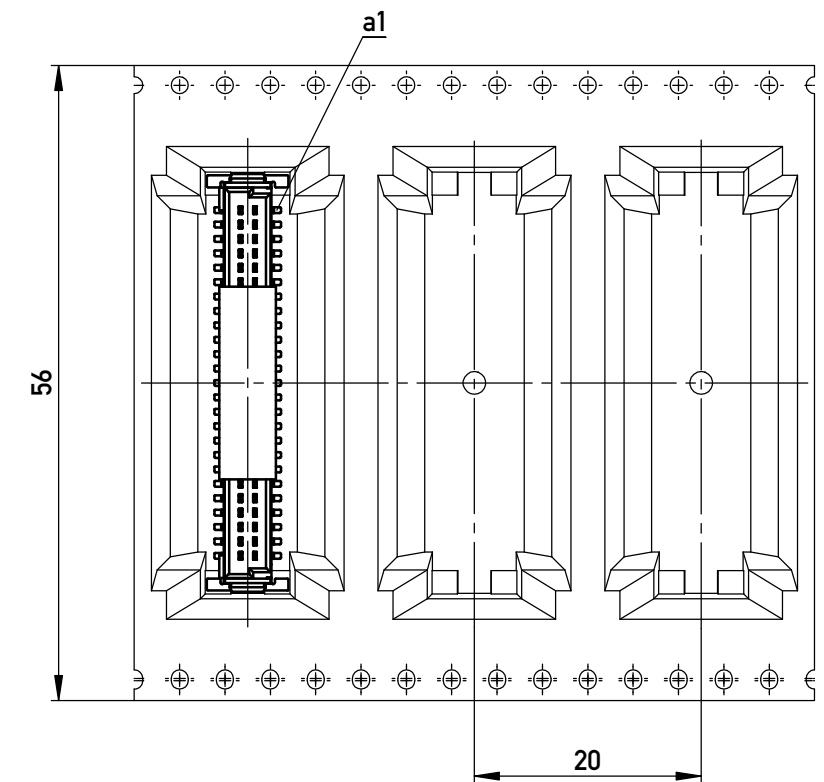

Leiterplatten-Layout Vorschlag für SMT  
 PCB-Layout Proposal for SMT

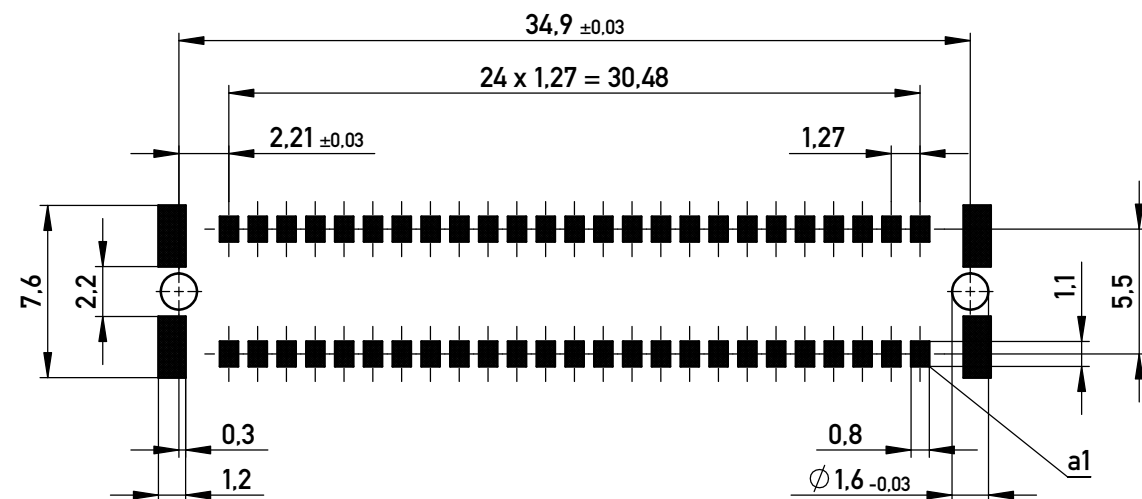

BA 8-23 - hohe Bauhöhe  
 type 8-23 - High Profile

Information:		Tolerances	Scale 3:1	BA 8-23 - hohe Bauhöhe	
All rights reserved. Only for Information. To ensure that this is the latest version of this drawing, please contact one of the ERNI companies before using.		All Dimensions in mm	Designation	type 8-23 - High Profile	
Subject to modification without prior notice. Drawing will not be updated.		www.ERNI.com	Messerrl. SMC-Q 50-SMD-BA8-23	Male SMC-Q 50-SMD-type8-23	
ERNI		234208	1		
f	07.09.2018	Class SMCQ		A3	
Index	Date				

Copyright by ERNI Production GmbH & Co. KG  
 Proprietary notice pursuant to ISO 16016 to be observed.