

THIS DRAWING IS UNPUBLISHED. RELEASED FOR PUBLICATION
 © COPYRIGHT BY TYCO ELECTRONICS CORPORATION. ALL RIGHTS RESERVED.

LOC	DIST	REVISIONS			
P	LTR	DESCRIPTION	DATE	DWN	APVD
AG	53	01	REVISED PER ECO-08-021128	02SEP08	DH DB

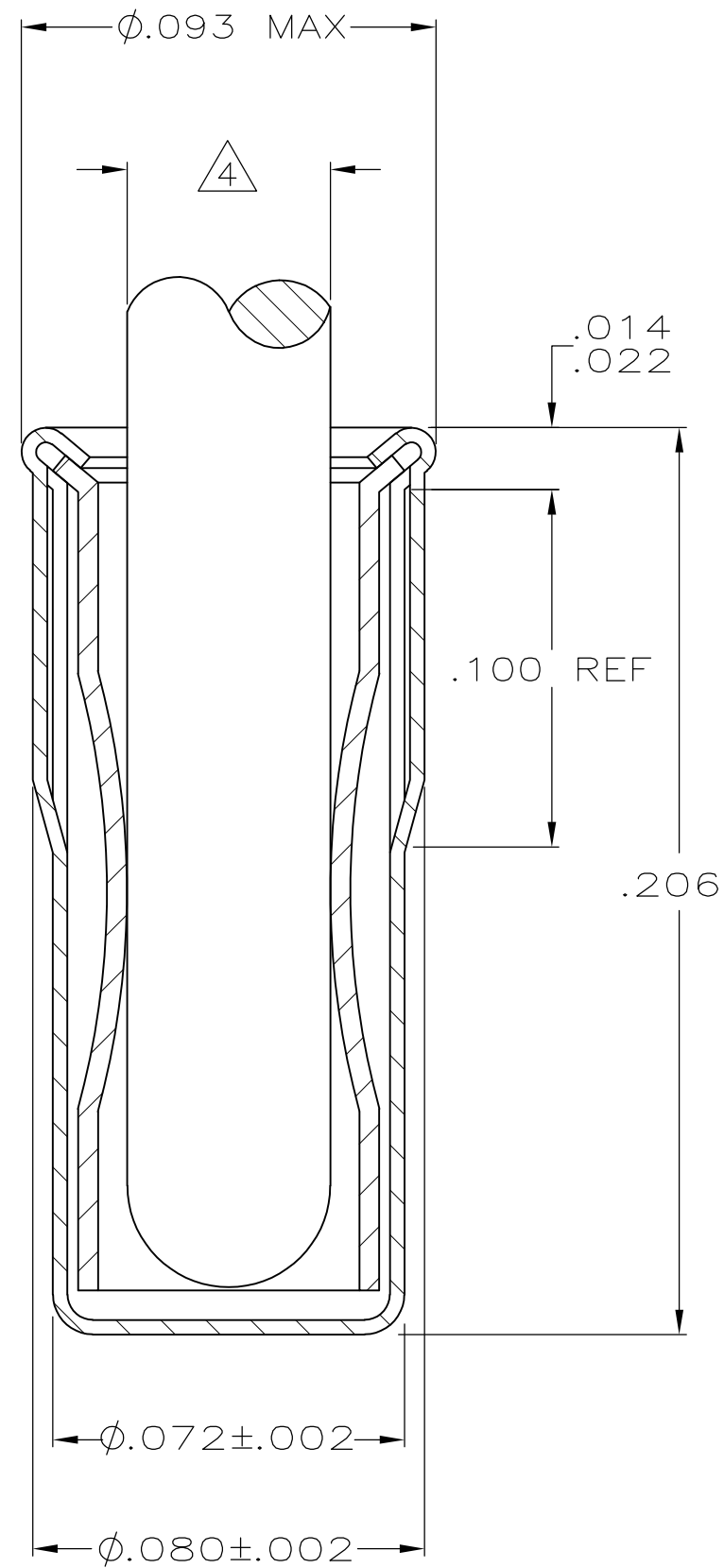
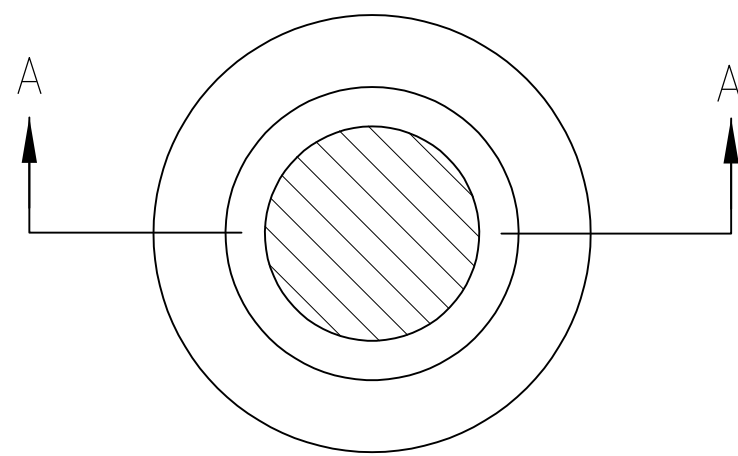

SECTION A-A

- ① PLATING:
 SPRING:
 NICKEL UNDERPLATING ALL OVER, MATING SURFACES PLATED TO MEET PERFORMANCE REQUIREMENTS OF TYCO ELECTRONICS PRODUCT SPECIFICATION 108-14008.
 EYELET:
 TIN PLATE PER ASTM B 545 .000100 MIN THICK
- 2. RECOMMENDED HOLE SIZES PLATED OR UNPLATED:
 HAND OR MACHINE INSERTION; .075-.078.
- 3. TO INSURE PROPER SPRING TENSION DO NOT EXCEED A .002 DIFFERENCE IN PIN DIA WHEN CHANGING TO A SMALLER PIN.

④ RECOMMENDED PIN DIA .040.

⑤ MATERIAL:
 SPRING: BERYLLIUM COPPER PER ASTM B 194
 EYELET: COPPER PER ASTM B 152

5645508-1
 PART NO

THIS DRAWING IS A CONTROLLED DOCUMENT.		DWN G. ATTADIA 20APR2005	Tyco Electronics Corporation Harrisburg, PA 17105-3608	
DIMENSIONS: INCHES		CHK J. HAVENER 20APR2005	NAME ASSEMBLY, SOCKET, SPRING, MINIATURE SERIES 4	
TOLERANCES UNLESS OTHERWISE SPECIFIED:		APVD J. HAVENER 20APR2005	PRODUCT SPEC 108-14008	RESTRICTED TO -
0 PLC ± - 1 PLC ± - 2 PLC ± - 3 PLC ± .008 4 PLC ± - ANGLES ± -		APPLICATION SPEC 114-13152	SIZE A2	CAGE CODE 00779
MATERIAL ⑤	FINISH ①	WEIGHT -	DRAWING NO C=5645508	SCALE NTS
CUSTOMER DRAWING			SHEET 1 of 1	REV 01