

# PRODUCT DATA DRAWING

REVISION HISTORY			
REV	DESCRIPTION	DATE	APPROVED
-	DCN 37963	01/11	STW

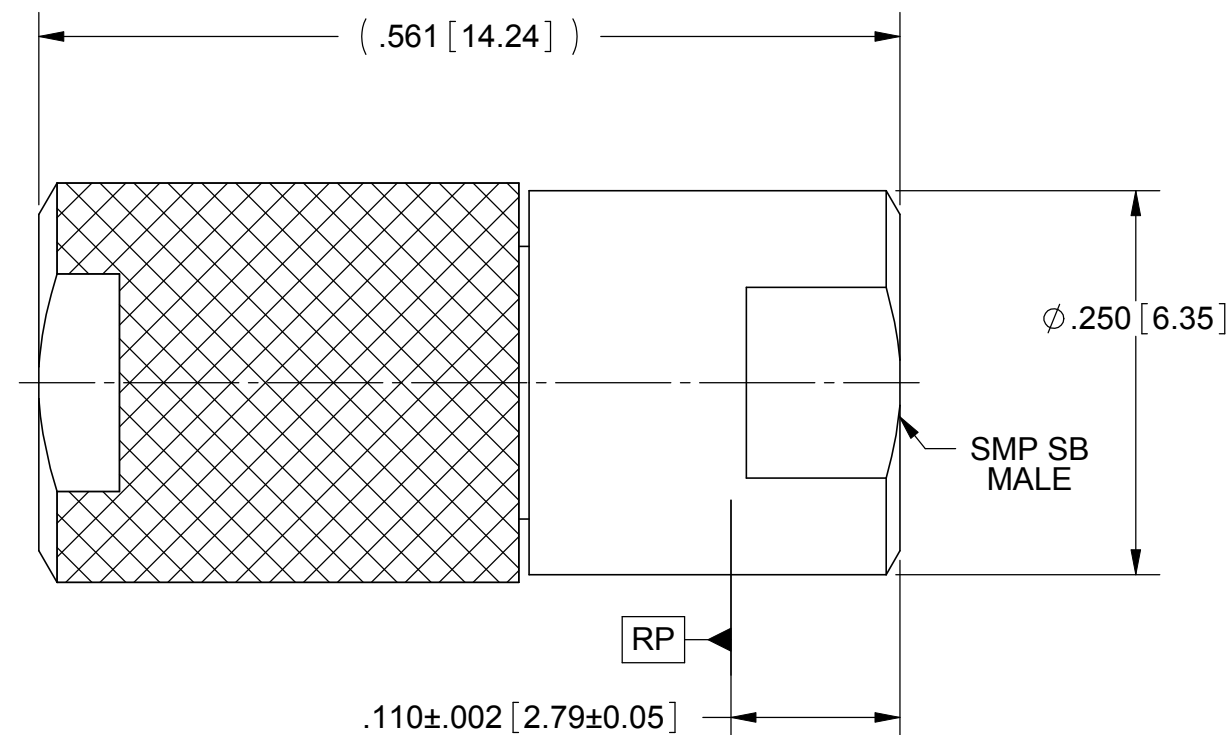
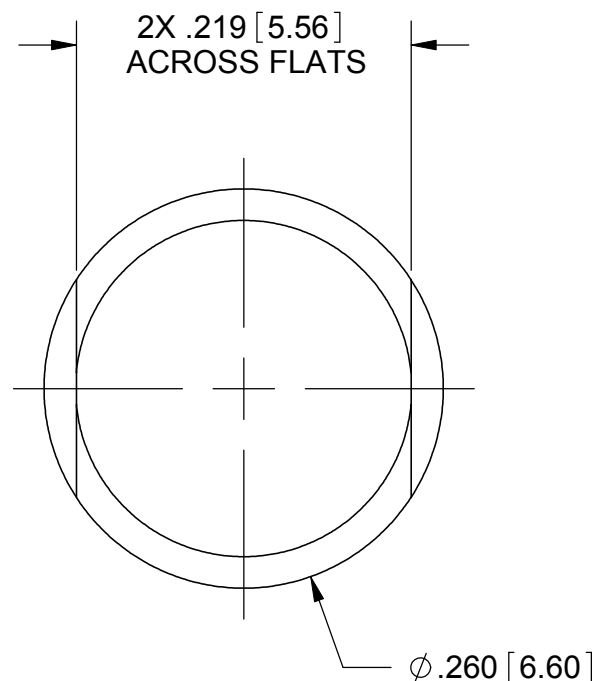
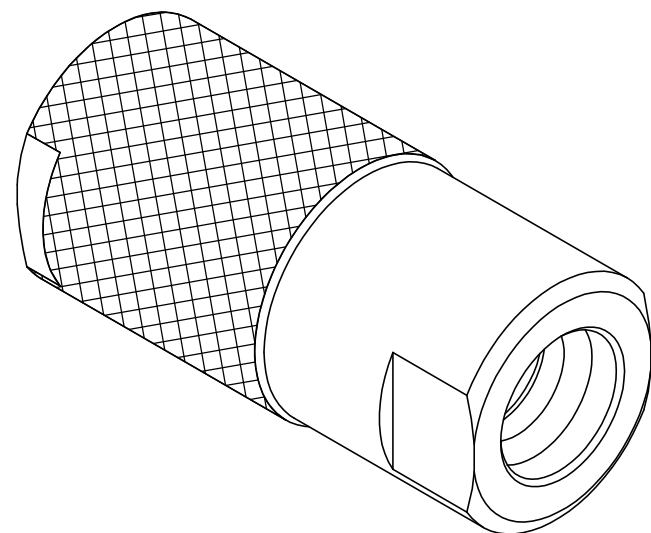

**MATERIAL:**

- BODIES, & INSERT: STAINLESS STEEL PER AMS-5640, ALLOY UNS S30300, TYPE 1
- CONTACT: BERYLLIUM COPPER PER ASTM B196, ALLOY No. UNS C17300, TD04
- SLEEVE: BRASS PER ASTM B16, ALLOY UNS No. C36000
- INSULATOR: PTFE PER ASTM D1710, TYPE I, GRADE 1, CLASS B
- RESISTOR ELEMENT: ALUMINUM NITRIDE SUBSTRATE WITH TANTILUM NITRIDE RESISTOR

**FINISH:**

- BODIES & INSERT: PASSIVATED PER AMS-2700, TYPE 2
- CONTACT: GOLD PER ASTM B488, TYPE II, CODE C, CLASS 1.27; OVER NICKEL PER AMS-QQ-N-290, CLASS 1, .00005" MIN.

**PERFORMANCE:**

- IMPEDANCE: 50 OHMS
- FREQ. RANGE: DC TO 18.0 GHZ
- VSWR: 1.20:1 DC TO 15 GHZ  
1.25:1 15 TO 18 GHZ
- OPERATING TEMP.: -55°C TO +125°C
- AVG. POWER: 0.5 WATT (POWER INPUT DERATED LINEARLY FROM 25°C TO .05 WATTS AT 125°C)
- PEAK POWER: 100 WATTS (PEAK POWER FOR A DUTY CYCLE OF 5X10<sup>-4</sup> MAXIMUM PULSE DURATION OF 5 MICROSECONDS)

MATERIAL: SEE NOTES	DIMENSIONS ARE IN INCHES TOLERANCES: FRACTIONAL: ±1/64 ANGULAR: X° ±1'0" X"X' ±15"	UNLESS OTHERWISE SPECIFIED 1) ALL DIMENSIONS ARE IN INCHES (MILLIMETERS) 2) ALL DIMENSIONS ARE AFTER PLATING 3) BREAK CORNERS & EDGES .005 R. MAX. 4) CHAM. 1ST & LAST THREADS. 5) SURFACE ROUGHNESS 63-MIL-STD-10. 6) DIA. 'S ON COMMON CENTERS TO BE CONCENTRIC WITHIN .005 T.I.R. 7) REMOVE ALL BURRS	<b>SV Microwave, Inc.</b> 2400 Centrepark West Drive, Suite 100 West Palm Beach, FL 33409
FINISH: SEE NOTES	DECIMAL: X ±.030 .XX ±.010 .XXX ±.005	INTERPRET DIMENSIONS AND TOLERANCES PER ASME Y14.5M - 1994	TITLE: SMP MALE SB TERMINATION
SURFACE AREA: N/A	THIRD ANGLE PROJECTION	DRAWN: FED 01/19/11	SIZE: B CAGE CODE: 95077 DWG. NO.: SF8012-6102
PROPRIETARY THE INFORMATION CONTAINED IN THIS DRAWING IS THE SOLE PROPERTY OF SV MICROWAVE, INC. ANY REPRODUCTION IN PART OR AS A WHOLE WITHOUT THE WRITTEN PERMISSION OF SV MICROWAVE, INC IS PROHIBITED.		CHECKED: STW 01/19/11	SCALE: 8:1 SHEET 1 OF 1
		APPROVED: STW 01/19/11	