

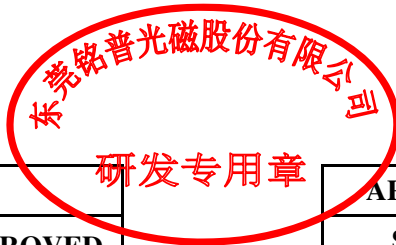

## Product Specification for Approval

WE ARE PLEASED IN SUBMITTING OUR SAMPLES WITH SPECIFICATION TO YOU FOR APPROVAL.

<b>CUSTOMER</b>	:	_____	
<b>DESCRIPTION</b>	:	<b>100/1000 BASE-T QUAD PORT THROUGH HOLE MAGNETICS</b>	
<b>MNC P/N</b>	:	<b>G3601DG</b>	
<b>VERSION</b>	:	<b>A0</b>	
<b>CUSTOMER P/N</b>	:	_____	
<b>ISSUED DATE</b>	:	<b>2020/04/27</b>	
<b>PHOTO OF PRODUCT</b>	:		
<b>WEIGHT</b>	:		<b>4.48g</b>
<b>MADE IN</b>	:		<b>CHINA</b>



APPROVED BY MNC			APPROVED BY CUSTOMER
PREPARED BY	CHECKED BY	APPROVED BY	SIGNATURE OR STAMP
			

1. PLEASE SEND BACK US A COPY OF THE SPECIFICATION WITH YOUR STAMP OR SIGNATURE ONCE THE SAMPLES APPROVED.
2. IT WILL BE DEEMED THE SAMPLES TO BE APPROVED IF NO FEEDBACK.

东莞铭普光磁股份有限公司  
 Add: Shipai Town, Dongguan City, Guangdong Province, China

TEL: +86-769-86921000  
 FAX: +86-769-81701563



**HISTORY FOR REVISED SPECIFICATION**

**Part No. G3601DG**

**INDEX**

1. INDEX-----1  
2. CHANGE RECORD-----1  
3. MECHANICAL-----2  
4. SCHEMATIC-----3  
5. PACKING-----4  
6. MATERIAL LIST-----5  
7. RECOMMENDED SOLDERING PROFILE-----6

**CHANGE RECORD**

<b>REV.</b>	<b>DESCRIPTION (Content or Reason For Change)</b>	<b>DATE</b>	<b>REVISOR</b>
A0	INITIAL RELEASE	2020-04-27	Jingjing Fu

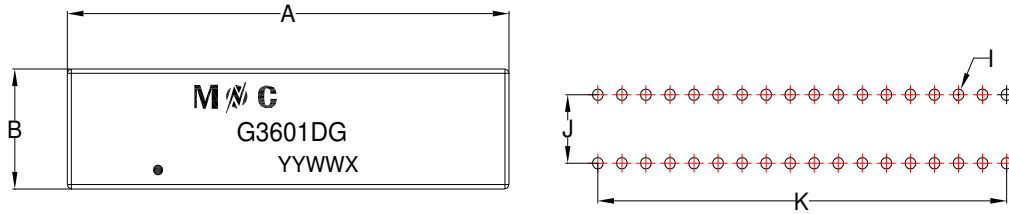
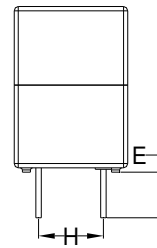
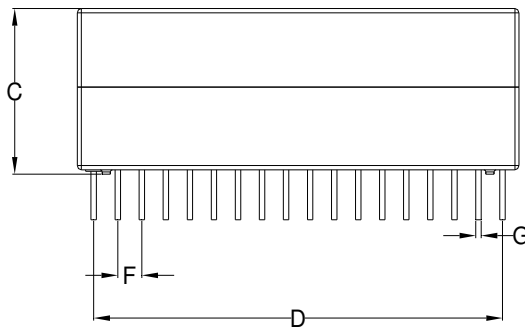
**SPECIFICATION**
**Part No. G3601DG**
**A. MECHANICAL :**

**SUGGESTED PAD LAYOUT**

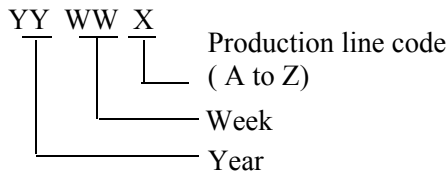
Note: White ink marking

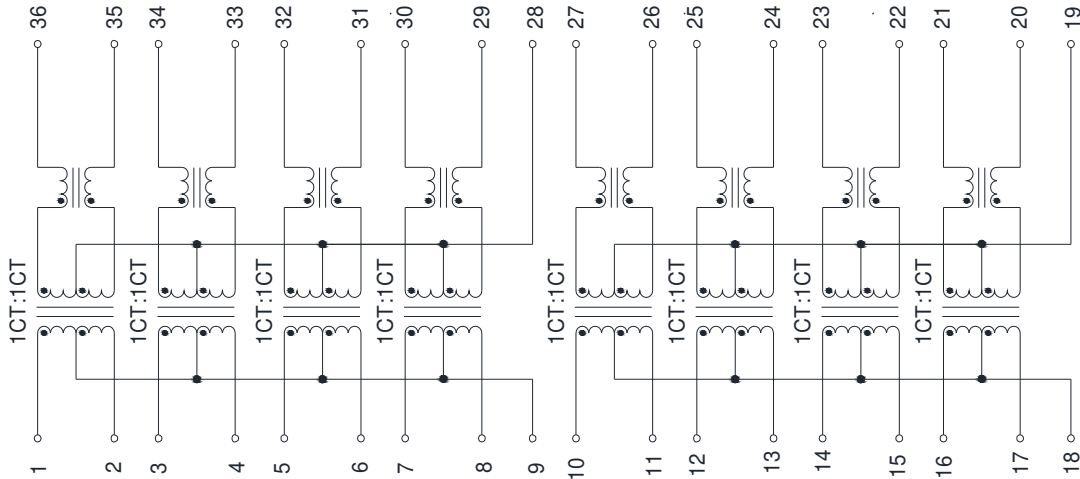

1. UNITS: mm/inch.
2. UNLESS OTHERWISE SPECIFIED ALL TOLERANCES ARE: TYPICAL
3. PIN LENGTH DON'T INCLUDE SOLDER POINT

DIM	MILLIMETERS			INCHES		
	MIN	NOM	MAX	MIN	NOM	MAX
A	32.20	32.70	33.20	1.268	1.287	1.307
B	7.90	8.40	8.90	0.311	0.331	0.350
C	/	/	12.00	/	/	0.472
D	29.76	30.26	30.76	1.172	1.191	1.211
E	2.90	3.20	3.50	0.114	0.126	0.138
F	/	1.78	/	/	0.070	/
G	/	0.40	/	/	0.016	/
H	4.30	4.80	5.30	0.169	0.189	0.209
I	/	0.80	/	/	0.031	/
J	/	4.80	/	/	0.189	/
K	/	30.26	/	/	1.191	/

**SPECIFICATION**
**Part No. G3601DG**
**B. SCHEMATIC :**

**C. ELECTRICAL SPECIFICATION @25°C**

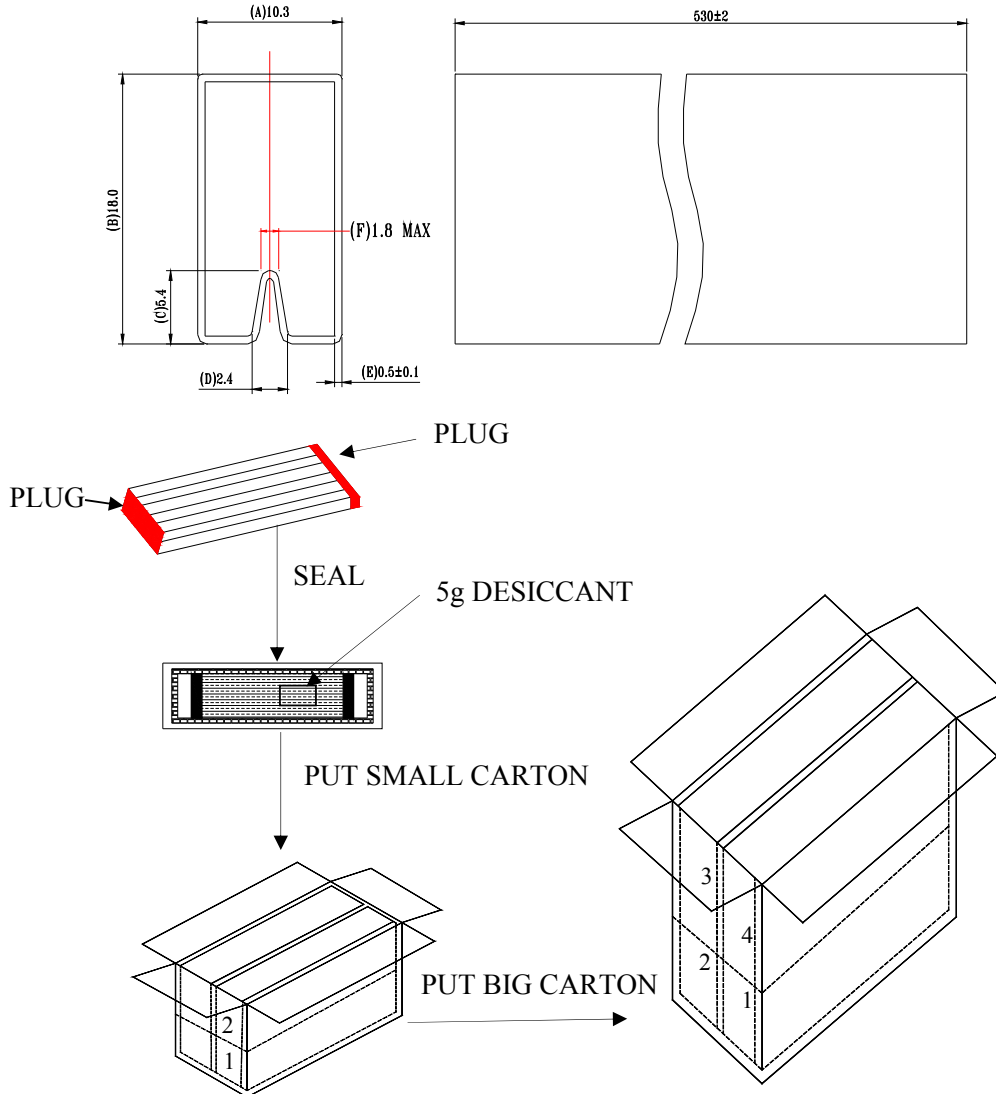
ITEM	SPECIFICATION	TEST CONDITION	TEST EQUIPMENT
INDUCTANCE :	350uH MIN.	100KHz 0.2V 8mA DC Bias	TH2819XB OR EQU.
LEAKAGE INDUCTANCE :	0.50uH MAX.	100KHz,0.2V	TH2819XB OR EQU.
INTERWINDING CAPACITANCE :	100pF TYP.	100KHz,0.2V	TH2819XB OR EQU.
DC RESISTANCE :	1.2Ω MAX.	AT 25 °C	TOS 8020 OR EQU.
TURNS RATIO :	1CT:1CT±5%		TH2819XB OR EQU.
POLARITY :	1-36,3-34,5-32,7-30,10-27,12-25,14-23,16-21 IN-PHASE		
INSERTION LOSS :	-1.1dB MAX.	0.5-100 MHz	E5061A OR EQU.
RETURN LOSS :	-18dB MIN.	0.5-40 MHz	E5061A OR EQU.
	-12+20log(f/80)dB MIN.	40.1-100 MHz	
CROSS TALK :	-35dB MIN.	0.5-40 MHz	E5061A OR EQU.
	-33+20*log(f/50)dB MIN.	40.1-100 MHz	
CMRR :	-30dB MIN.	0.5-100 MHz	E5061A OR EQU.
ISOLATION HI-POT :PRI TO SEC	1500VAC	1mA,60S	7152AB OR EQU.
	1650VAC	1mA,6S	
OPERATING TEMPERATURE	0°C TO 70°C		

**PACKAGE**
**Part No. G3601DG**
**D. PACKING:**
**a. PACKAGING AS BELOW (ONLY FOR A REFERENCE):**

**b. Q'TY:**

- 15 PCS PER TUBE
- 4 TUBES PER BUNDLE (60 PCS)
- 12 BUNDLES +2 TUBES PER BAG (750 PCS)
- 1 BAG PER SMALL CARTON
- 4 SMALL CARTON PER BIG(3000PCS)

**c. LABEL:**

**REMARK:**

ABOVE PACKING IS FOR YOUR REFERENCE ONLY, WHICH MIGHT BE CHANGED WITHOUT NOTICE.

**MATERIAL LIST**
**Part No. G3601DG**
**E.BOM**

<b>MATERIAL LIST</b>					
<b>NO.</b>	<b>ITEM</b>	<b>MATERIAL</b>	<b>RATING</b>	<b>SUPPLIER OF MATERIAL</b>	<b>UL</b>
<b>1</b>	<b>CORE</b>	<b>Mn-Zn</b>	-----	<b>YEAN SHING</b>	<b>N/A</b>
			-----	<b>ZHONGSHAN CRC ELECTRONICS FACTORY</b>	<b>N/A</b>
		<b>Ni-Zn</b>	-----	<b>YEAN SHING</b>	<b>N/A</b>
			-----	<b>ZHONGSHAN CRC ELECTRONICS FACTORY</b>	<b>N/A</b>
<b>2</b>	<b>COPPER WIRE</b>	<b>QPN180</b>	<b>180℃</b>	<b>ZHUHAI SUNTEK WIRE CO.,LTD</b>	<b>E234867</b>
		<b>Polysol 180</b>	<b>180℃</b>	<b>ELEKTRISOLA(MALAYSIA) SDN.BHD.</b>	<b>E258243</b>
<b>3</b>	<b>CASE</b>	<b>PF2A5-151J(b)</b>	<b>V-0</b>	<b>CHANGSHU SOUTH-EAST PLASTIC CO.,LTD</b>	<b>E136137</b>
		<b>T378J</b>	<b>V-0</b>	<b>CHANG CHUN CHEMICAL(ZHANGZHOU) CO.,LTD.</b>	<b>E59481</b>
<b>4</b>	<b>PIN</b>	<b>CP WIRE</b>	-----	<b>HIFAM</b>	<b>N/A</b>
<b>5</b>	<b>EPOXY</b>	<b>3300A/B</b>	-----	<b>DONGGUAN EATTO ELECTRONIC MATERIAL CO.,LTD</b>	<b>E218090</b>

**RECOMMENDED WAVE SOLDERING PROFILE****Part No. G3601DG****a. RECOMMENDED WAVE SOLDERING PROFILE:****CONDITION:**

- a.1. AVAILABLE FOR ALL THE THROUGH HOLE PARTS
- a.2. SOLDERING METHOD: WAVE SOLDERING
- a.3. SOLDER: Sn-0.7Cu
- a.4. THE RECOMMENDED WAVE SOLDERING CURVE IS AS BELOW

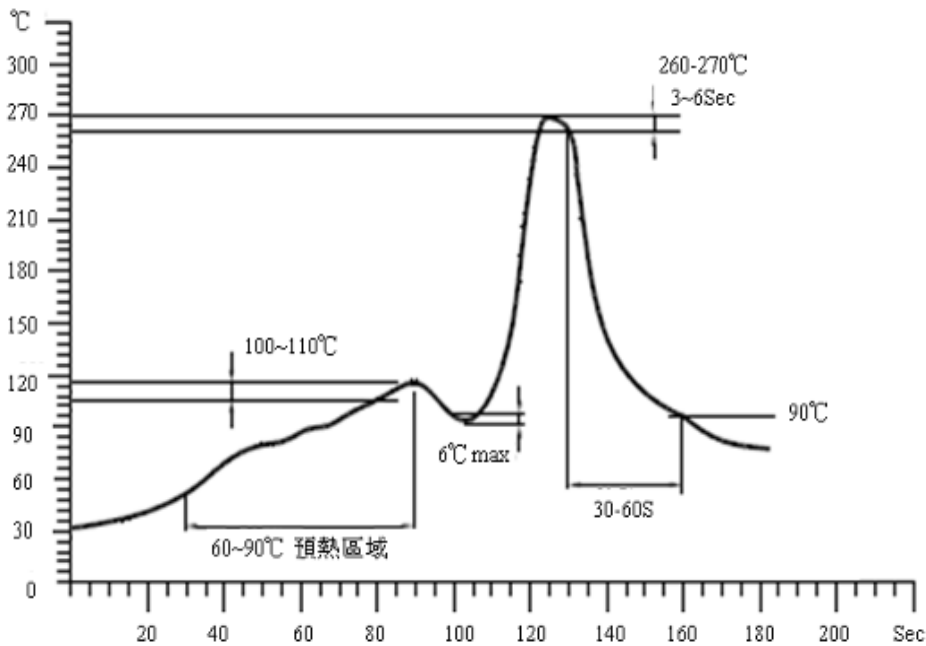
**b. MOISTURE SENSITIVE LEVEL:**

- b.1. LEVEL: 1
- b.2. SHELF LIFE: UNLIMITED
- b.3. STORAGE CONDITION:  $\leq 30^{\circ}\text{C}/85\% \text{RH}$