

Customer Information Sheet

DRAWING No.: W2334-00

IF IN DOUBT - ASK

©

NOT TO SCALE

THIRD ANGLE PROJECTION

ALL DIMENSIONS IN mm

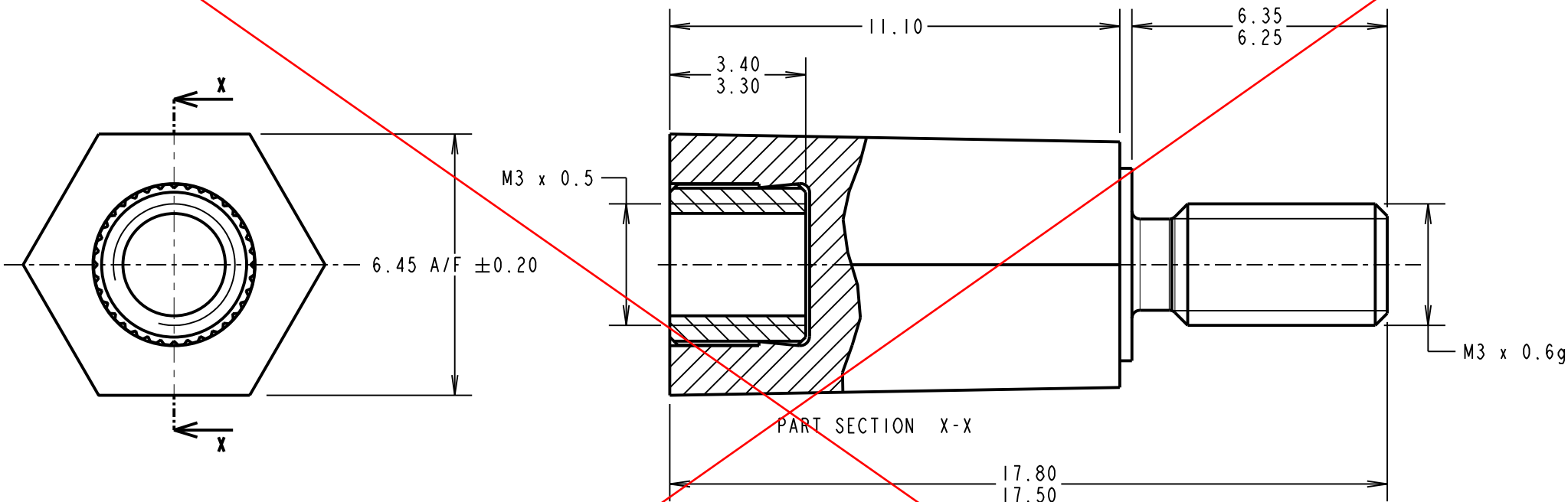

SPECIFICATIONS:

MATERIAL:

INSULATOR = POLYAMIDE 46, BLACK

INSERTS = BRASS

FINISH:

THREAD INSERT = 1.25µ NICKEL

STUD INSERT = 1.25µ NICKEL

ELECTRICAL:

CURRENT RATING = 10A MAX

VOLTAGE PROOF = 10kV MIN

ENVIRONMENTAL:

OPERATING TEMPERATURE = -55°C TO +125°C

OBSOLETE

SM	7	08.02.11	11115
NAME	ISS.	DATE	C/NOTE
APPROVED: S. MCCULLAGH			
CHECKED: M. G. PLESTED			
DRAWN: K. SHIER			
CUSTOMER REF.:			
ASSEMBLY DRG:			

HARWIN

HARWIN USA
TEL: 603 893 5376
FAX: 603 893 5396
mis@harwin.com

HARWIN Europe (UK)
TEL: 023 9231 4545
FAX: 023 9231 4590
mis@harwin.co.uk

HARWIN Asia
TEL: +65 6 779 4909
FAX: +65 6 779 3868
mis@harwin.com.sg

THIS DRAWING AND ANY INFORMATION OR DESCRIPTIVE MATTER SET OUT HEREON ARE CONFIDENTIAL AND COPYRIGHT PROPERTY OF THE HARWIN GROUP AND MUST NOT BE DISCLOSED, LOANED, COPIED OR USED FOR MANUFACTURING, TENDERING OR FOR ANY OTHER PURPOSE WITHOUT THEIR WRITTEN PERMISSION.

TOLERANCES
X. = ±1mm
X.X = ±0.25mm
X.XX = ±0.10mm
X.XXX = ±0.01mm
ANGLES = ±5°
UNLESS STATED

MATERIAL:
SEE ABOVE
FINISH: SEE ABOVE
S/AREA: mm²

TITLE:
INSULATED TERMINAL SINGLE TURRET
DRAWING NUMBER:
W2334-00
SHT
2 OF 2