

REVISIONS					
P	LTR	DESCRIPTION	DATE	DWN	APVD
Y		REV PER ECO 19-019228	4-17-20	CT	DM

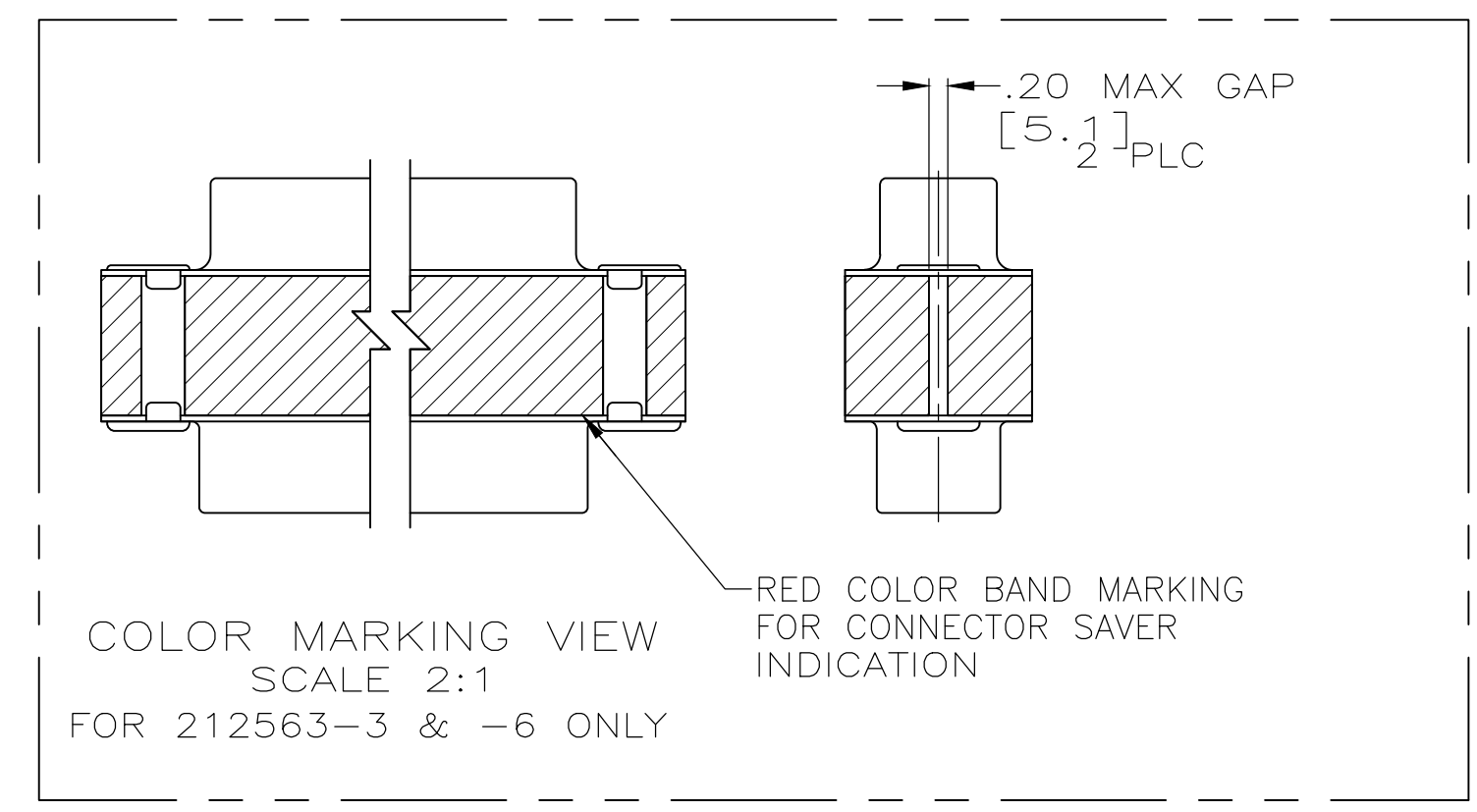
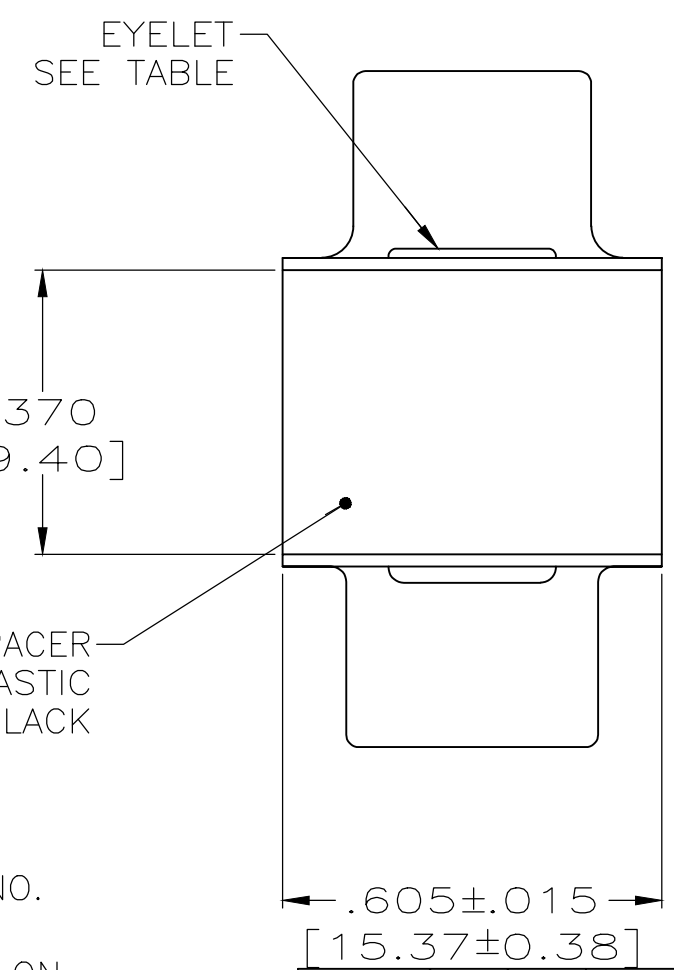
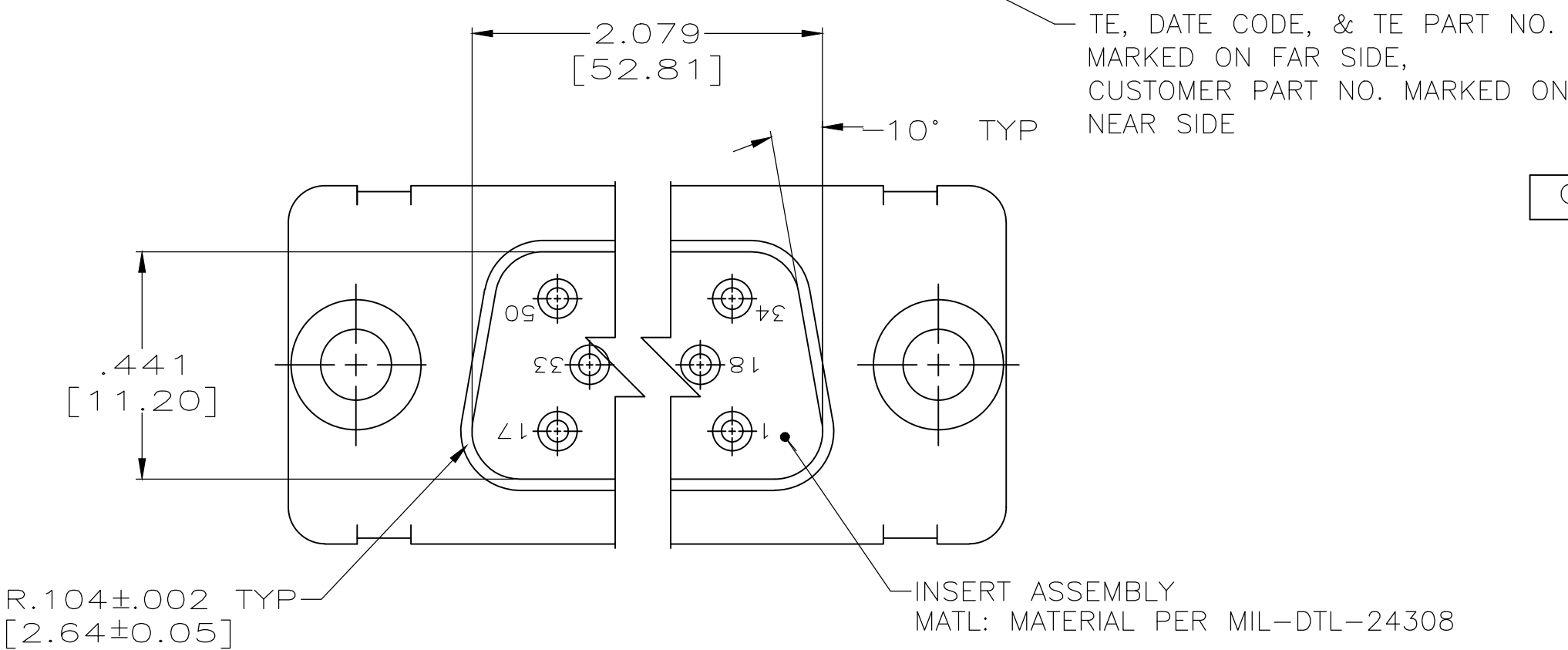
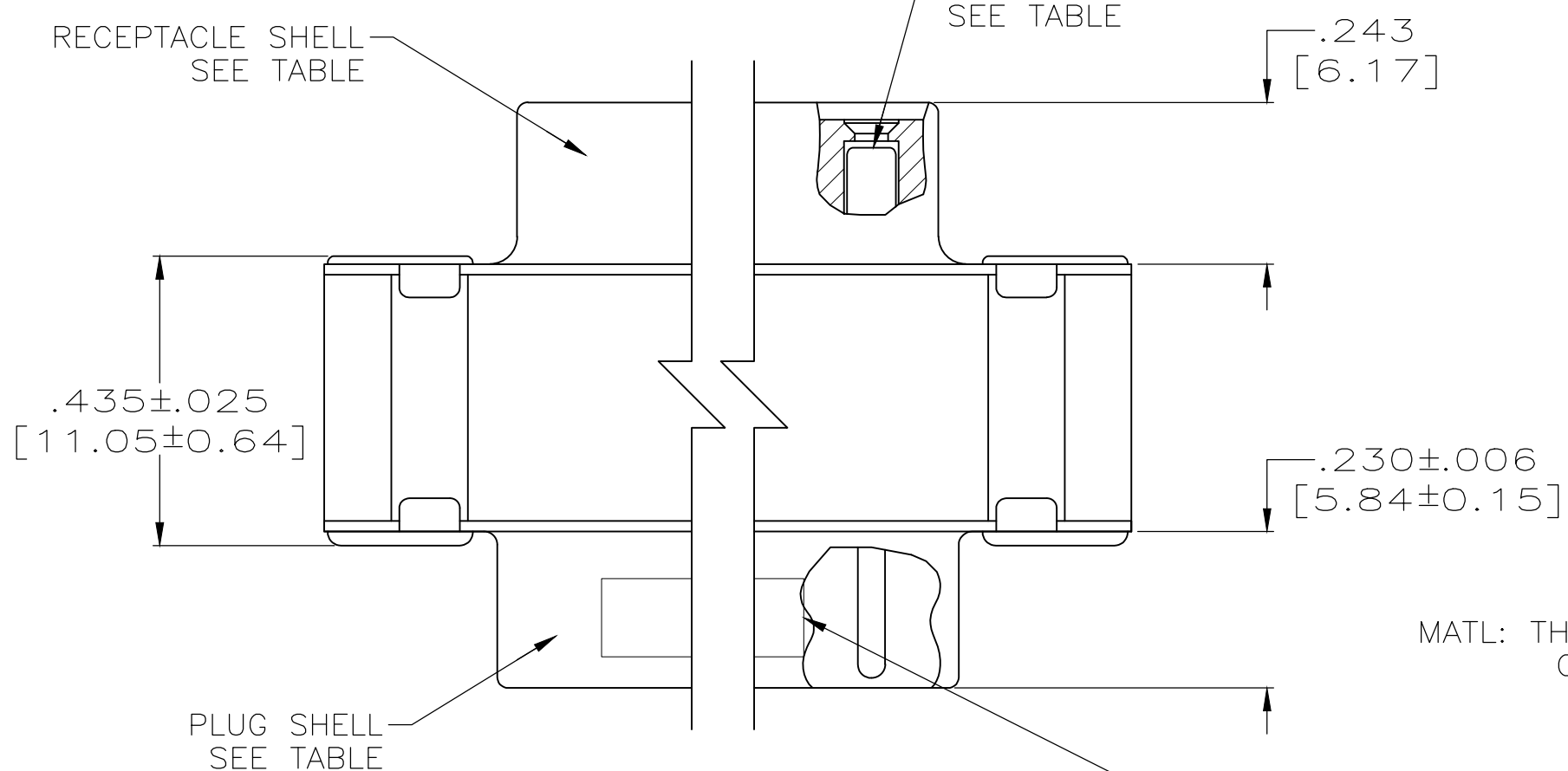
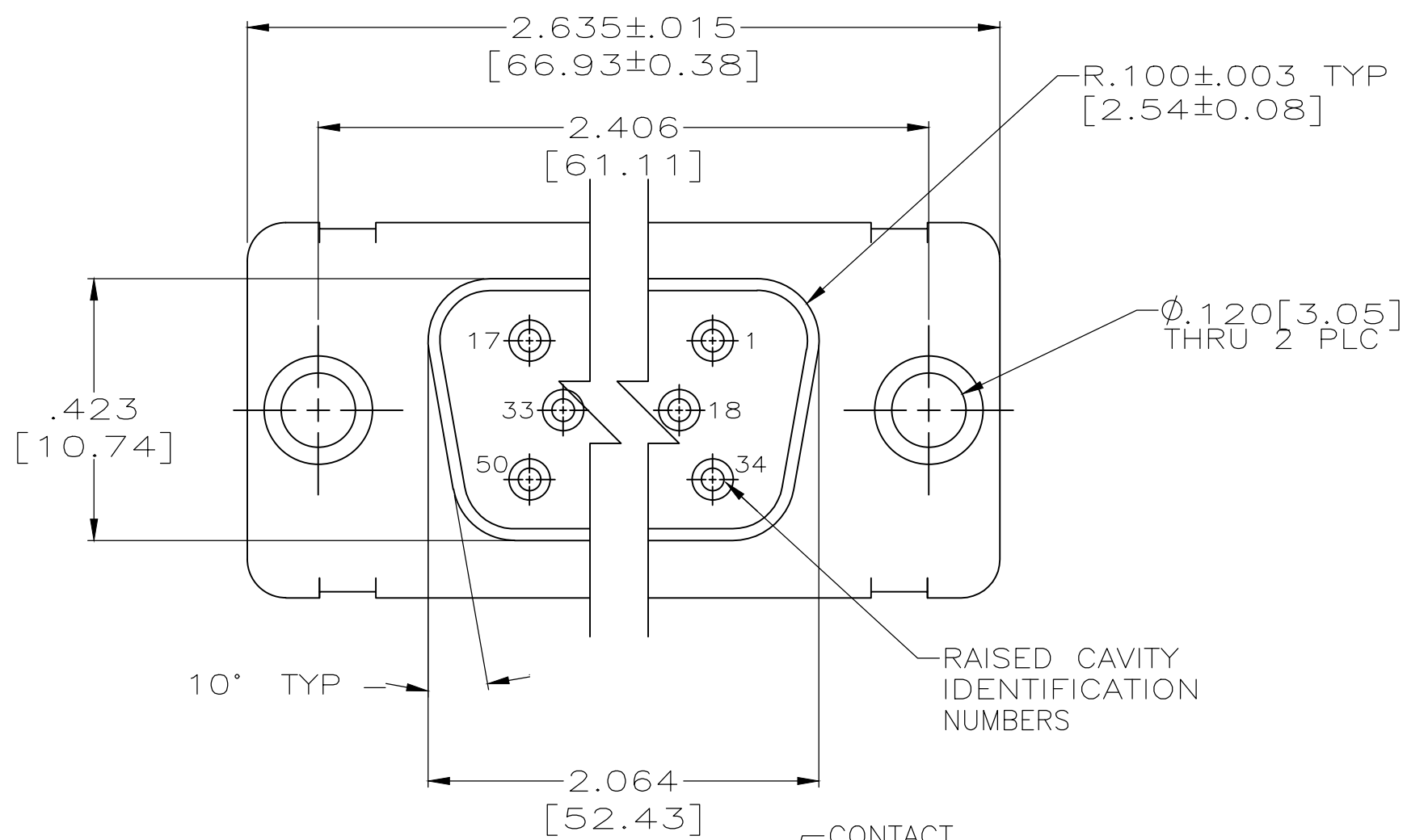

- CONTACTS INCLUDED IN ASSEMBLY.
 - △ MATL: STEEL, PER ASTM-A-109.
 - △ FINISH: CADMIUM PER QQ-P-416.
 - △ CONTACT
 - BODY MATL: BERYLLIUM COPPER PER ASTM-B-197.
 - BODY FINISH: PLATED GOLD, .000050 MIN THK PER MIL-G-45204 OVER NICKEL, .000050 MIN THK PER QQ-N-290.
 - △ HOOD MATL: STAINLESS STEEL PER ASTM-A-167.
 - △ HOOD FINISH: PASSIVATED PER ASTM-A-380.
 - △ FINISH: PLATED ZINC .00020 MIN THK PER ASTM-B-633. YELLOW CHROMATE FINISH.
 - △ MATL: BRASS PER ASTM-B-36.
 - △ FINISH: PLATED GOLD, .000050 MIN THK PER MIL-G-45204 OVER COPPER, .000100 MIN THK PER MIL-C-14550.
 - △ CONTACT
 - BODY MATL: BERYLLIUM COPPER PER ASTM-B-197.
 - BODY AND HOOD FINISH: PLATED GOLD, .000050 MIN THK PER MIL-G-45204 OVER COPPER, .000100 MIN THK PER MIL-C-14550.
 - HOOD MATL: BRASS PER ASTM-B-36

OBSOLETE	△ △	△ △	△	4U884 SOCN R10002677-0105	212563-6
	△ △	△ △	△	PT2-111-11	212563-5
	△ △	△ △	△	-	212563-4
	△ △	△ △	△	(1J02-105)	212563-3
	△ △	△ △	△	-	212563-2
	△ △	△ △	△	-	212563-1
EYELET	SHELLS	CONTACT	CUSTOMER P/N	PART NO.	

THIS DRAWING IS A CONTROLLED DOCUMENT.		DWN 27-May-15 MANJUNATH G M		TE Connectivity	
DIMENSIONS: INCHES		CHK 27-May-15 CHARLES THOMAS		CONNECTOR SAVER, AMPLIMITE 50 POSITION, SIZE 5, SERIES 109	
TOLERANCES UNLESS OTHERWISE SPECIFIED:		APVD 27-May-15 CHARLES THOMAS	NAME	SIZE	CAGE CODE
0 PLC ± -	1 PLC ± -	PRODUCT SPEC	NAME	DRAWING NO	RESTRICTED TO
2 PLC ± -	3 PLC ± .005 [0.13]	APPLICATION SPEC	SIZE	CAGE CODE	DRAWING NO
4 PLC ± -	ANGLES ± -	FINISH	WEIGHT	0.000000	A2 00779 C=212563
MATERIAL	FINISH	WEIGHT	0.000000	A2 00779 C=212563	RESTRICTED TO
CUSTOMER DRAWING			SCALE	4:1	SHEET 1 of 1

212563 212563