

THIS DRAWING IS UNPUBLISHED. RELEASED FOR PUBLICATION
 © COPYRIGHT BY TYCO ELECTRONICS CORPORATION. ALL RIGHTS RESERVED.

LOC	DIST	REVISIONS					
GP	00	P	LTR	DESCRIPTION	DATE	DWN	APVD
		W		REVISED PER ECO-09-001588	25JUN2009	CJV	CWR
		W1		REVISED PER ECO-09-021826	01SEP09	KK	AEG

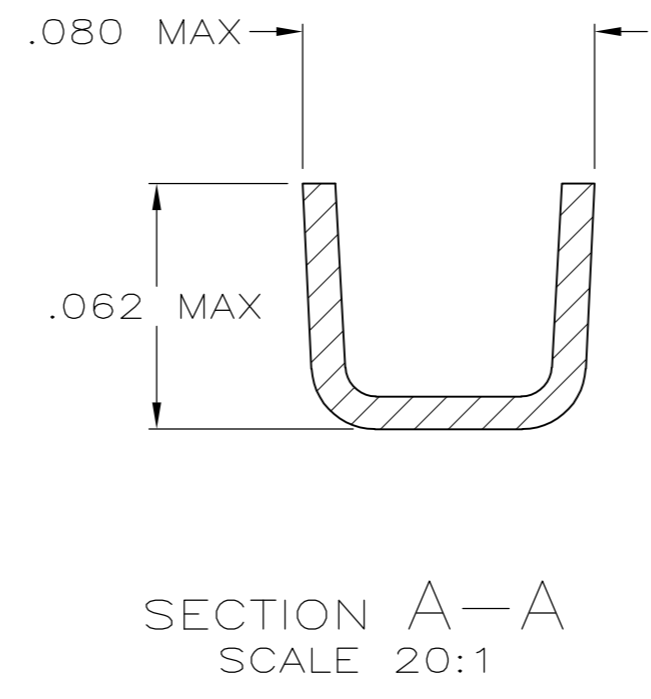
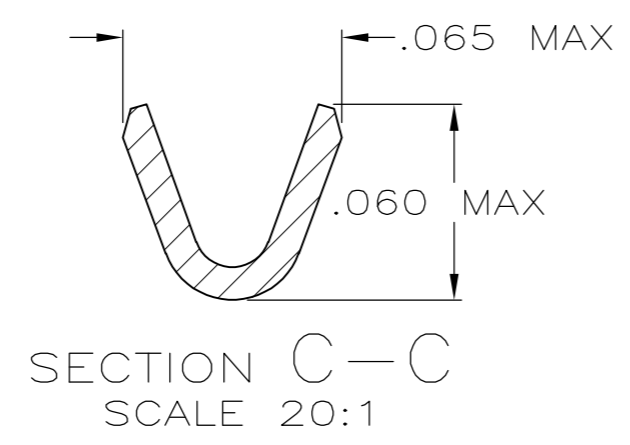
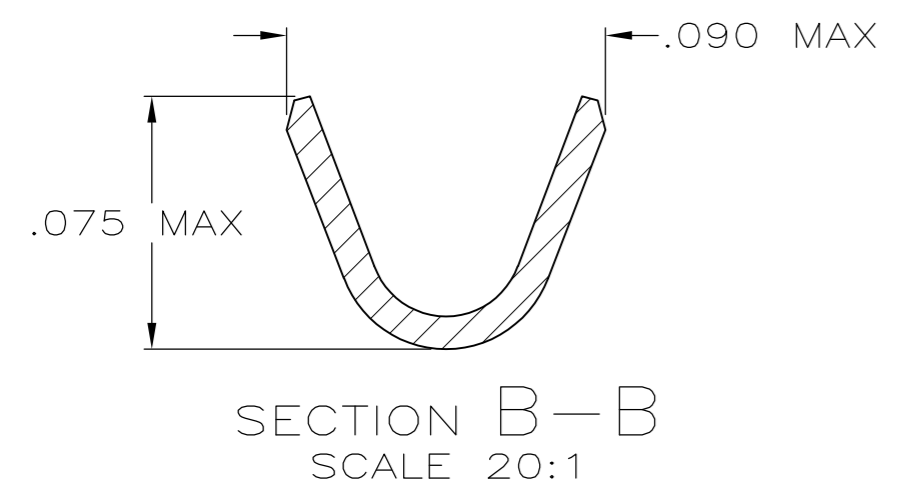
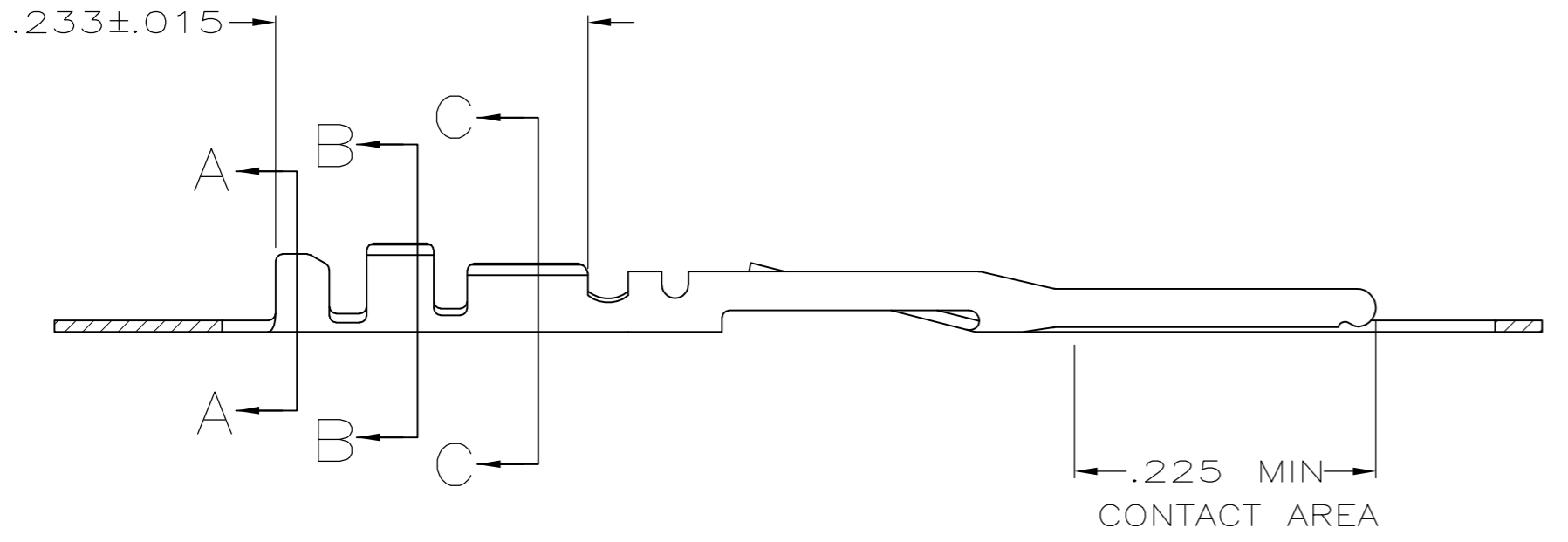
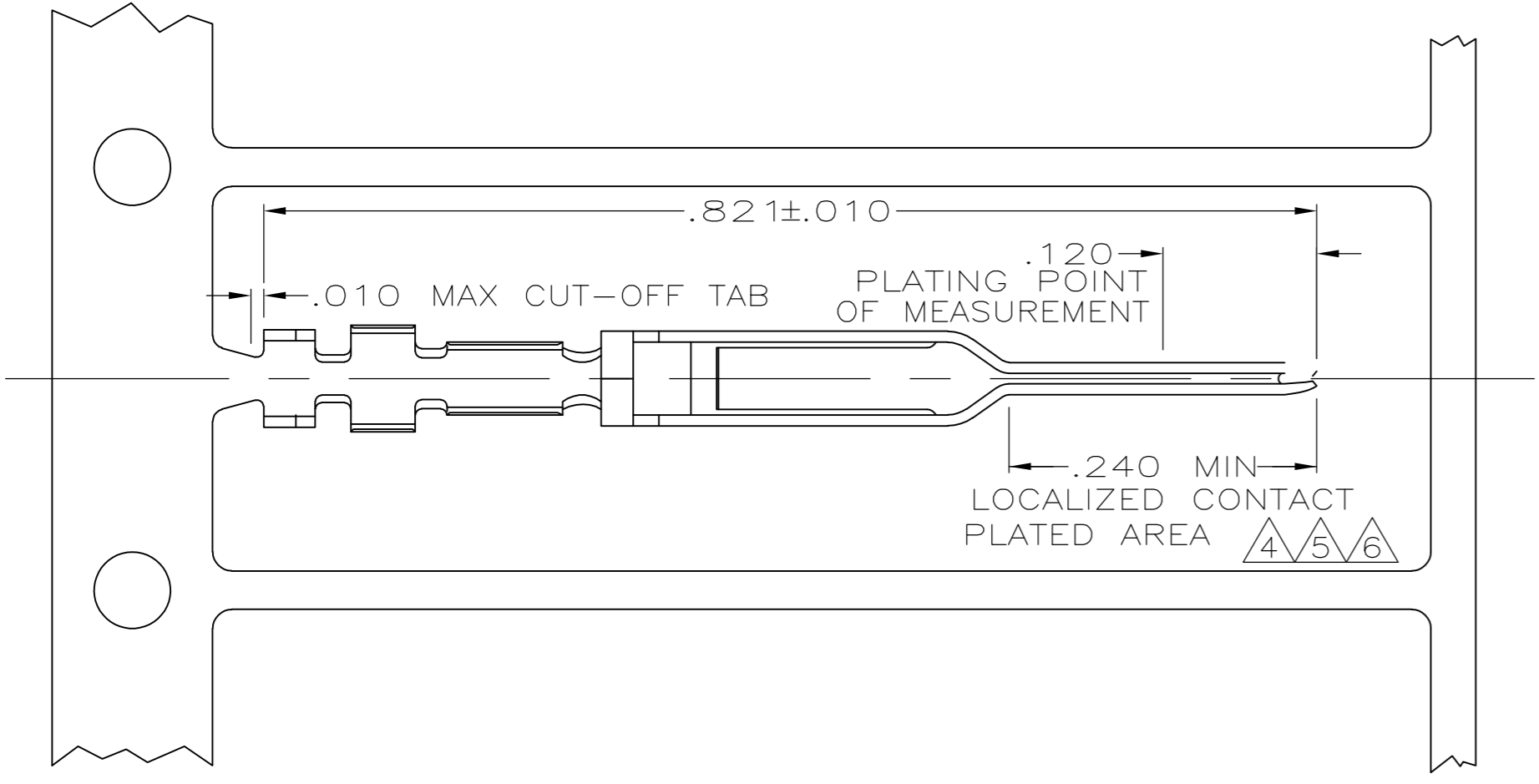

- 1 FOR STD APPLICATOR.
- 2 FOR MINI APPLICATOR.
- 3 FINISH: .000100 MIN THK BRIGHT-TIN LEAD OVER .000050 MIN THK NICKEL ON ENTIRE CONTACT.
- 4 FINISH: GOLD FLASH ALL OVER, .000015 THK GOLD IN LOCALIZED CONTACT PLATING AREA OVER .000050 MIN THK NICKEL ON ENTIRE CONTACT,
-OR-
GOLD FLASH OVER PALLADIUM-NICKEL, .000015 MIN TOTAL THK IN LOCALIZED CONTACT PLATING AREA AND GOLD FLASH ON REMAINDER OVER .000050 MIN NICKEL ON ENTIRE CONTACT.
- 5 FINISH: GOLD FLASH ALL OVER, .000030 THK GOLD IN LOCALIZED CONTACT PLATING AREA OVER .000050 MIN THK NICKEL ON ENTIRE CONTACT.
- 6 FINISH: GOLD FLASH ALL OVER, .000050 THK GOLD IN LOCALIZED CONTACT PLATING AREA OVER .000050 MIN THK NICKEL ON ENTIRE CONTACT.
- 7. FOR 26-32 AWG WIRE WITH AN INSULATION RANGE OF .025-.048 DIA.
- 8 OBSOLETE PART NO.
- 9 FINISH: .000100 MIN THK MATTE TIN OVER .000050 MIN THK NICKEL ON ENTIRE CONTACT.
- 10 OBSOLETE PARTS: OBSOLETE CIS STREAMLINING PER D.RENAUD/D.SINISI

10 OBSOLETE		2	9	
-	-	2	6	1-88048-4
-	LOOSE PIECE	6	8	1-88048-3
-	-	2	6	1-88048-2
-	-	1	6	1-88048-1
-	LOOSE PIECE	5	8	1-88048-0
-	-	1	5	88048-9
-	-	2	5	88048-8
-	-	1	3	88048-7
-	-	1	4	88048-6
88048-4	LOOSE PIECE	4		88048-5
-	-	2	4	88048-4
88048-2	LOOSE PIECE	3		88048-3
-	-	2	3	88048-2
SUPERSEDED BY	REMARKS	FINISH	PART NO.	

THIS DRAWING IS A CONTROLLED DOCUMENT.		DWN J. GALLUCCI 6-27-89	Tyco Electronics Corporation Harrisburg, PA 17105-3608	
DIMENSIONS: INCHES		CHK D.L. ROCKER 6-28-89	NAME	
TOLERANCES UNLESS OTHERWISE SPECIFIED: 0 PLC ± - 1 PLC ± - 2 PLC ± - 3 PLC ± .005 4 PLC ± - ANGLES ± -		APVD -	PRODUCT SPEC 108-9024	
MATERIAL PHOS. BRONZE		FINISH SEE TABLE	APPLICATION SPEC 114-16003	RESTRICTED TO -
		WEIGHT -	SIZE A2	CAGE CODE 00779
		CUSTOMER DRAWING	DRAWING NO C=88048	SCALE 8:1
			SHEET 1 OF 1	REV W1