

### SMD ■ A EASZ2025GA1



#### Features

- Package in 12mm tape on 7" diameter reel.
- Compatible with automatic placement equipment.
- EIA Std. package.
- Mono-color type.
- Pb-free.
- The product itself will remain within RoHS compliant version.
- Compliance with EU REACH
- Compliance Halogen Free .(Br <900 ppm ,Cl <900 ppm , Br+Cl < 1500 ppm)

#### Description

- The EASZ2025 SMD LED is much smaller than leaded components . Thus enable smaller board size. Higher packing density. Reduced storage space and finally smaller equipment to be obtained.
- Besides, light weight makes them ideal for miniature applications.
- Furthermore by automation assembly machines the accuracy is anticipated.

#### Applications

- Small indicator for indoor applications.
- Flat back-light for LCD, switches and symbols.
- Indicator and back-light in office equipment.
- Indicator and back-light for battery driven equipment.
- Indicator and back-light for audio and video equipment.
- Backlighting in dashboards and switches.
- Telecommunication : indicator and back-lighting in telephone and fax.

## Device Selection Guide

Chip Materials	Emitted Color	Resin Color
AlGaInP	Brilliant Yellow Green	Water Clear

## Absolute Maximum Ratings (Ta=25°C)

Parameter	Symbol	Rating	Unit
Reverse Voltage	$V_R$	5	V
Forward Current	$I_F$	25	mA
Peak Forward Current (Duty 1/10 @1KHz)	$I_{FP}$	60	mA
Power Dissipation	$P_d$	60	mW
Operating Temperature	$T_{opr}$	-40 ~ +85	°C
Storage Temperature	$T_{stg}$	-40 ~ +100	°C
Electrostatic Discharge	$ESD_{HBM}$	2000	V
Soldering Temperature	$T_{sol}$	Reflow Soldering : 260 °C for 5 sec. Hand Soldering : 350 °C for 3 sec.	

## Electro-Optical Characteristics (Ta=25°C)

Parameter	Symbol	Bank	Min.	Typ.	Max.	Unit	Condition
Luminous Intensity	$I_v$	E2	264	330	-----	mcd	$I_F=20mA$
		E3	396	462	-----		
		E4	528	594	-----		
Viewing Angle	$2\theta_{1/2}$		-----	25	-----	deg	$I_F=20mA$
Peak Wavelength	$\lambda_p$		-----	575	-----	nm	$I_F=20mA$
Dominant Wavelength	$\lambda_d$		-----	573	-----	nm	$I_F=20mA$
Spectrum Radiation Bandwidth	$\Delta \lambda$		-----	20	-----	nm	$I_F=20mA$
Forward Voltage	$V_F$		-----	2.0	2.4	V	$I_F=20mA$
Reverse Current	$I_R$		-----	-----	10	µA	$V_R=5V$

- Notes: 1. Tolerance of Luminous Intensity: ±11%  
 2. Tolerance of Dominant Wavelength: ±1nm  
 3. Tolerance of Forward Voltage: ±0.1V

**Typical Electro-Optical Characteristics Curves**

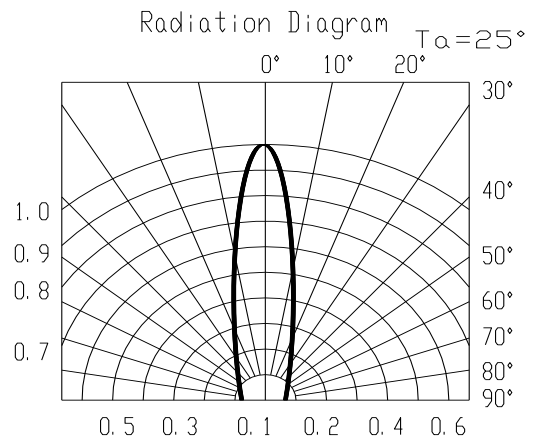
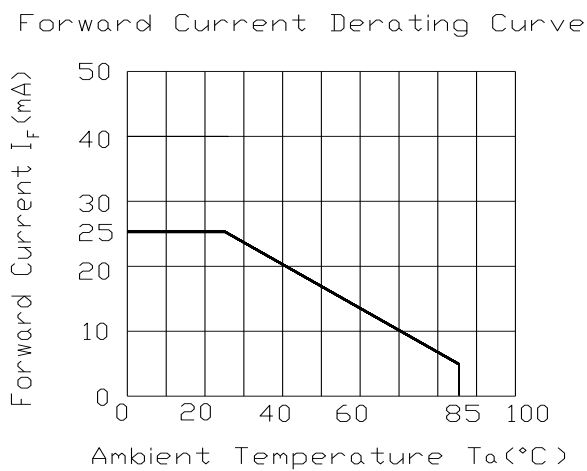
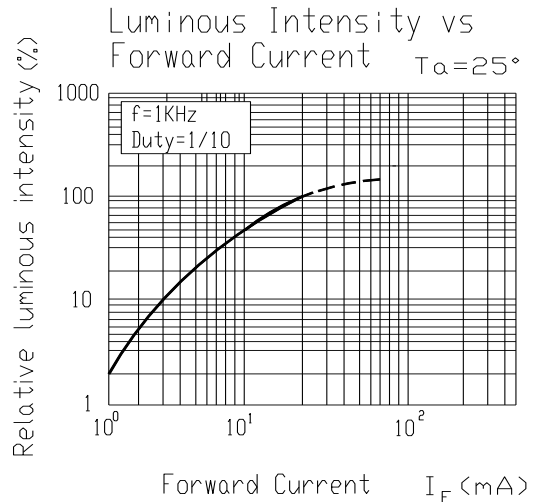
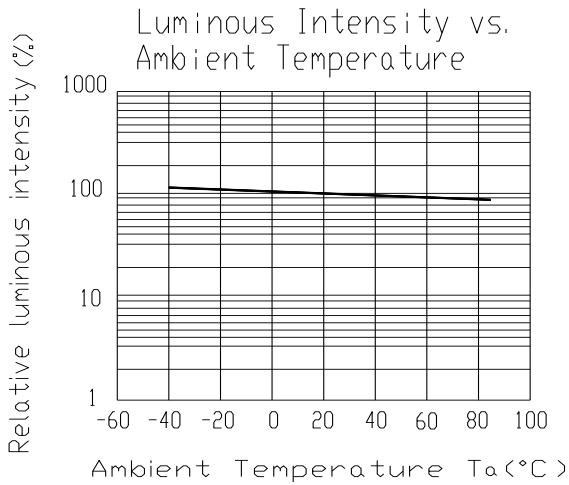
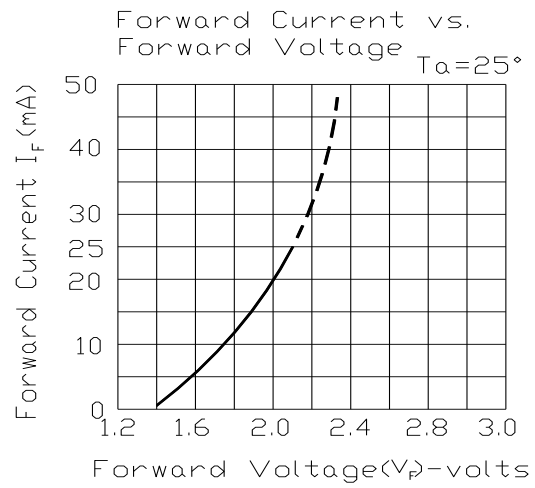
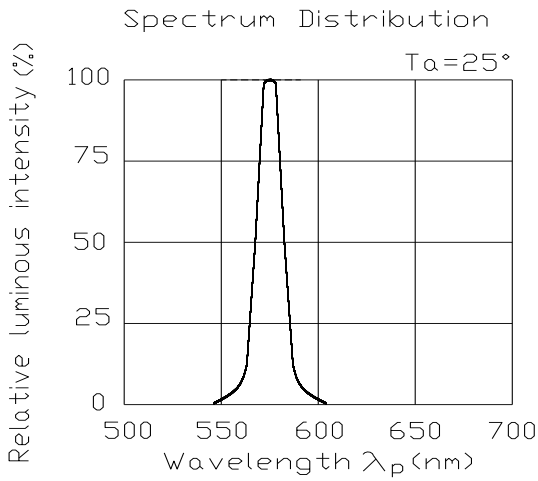

### Package Outline Dimensions

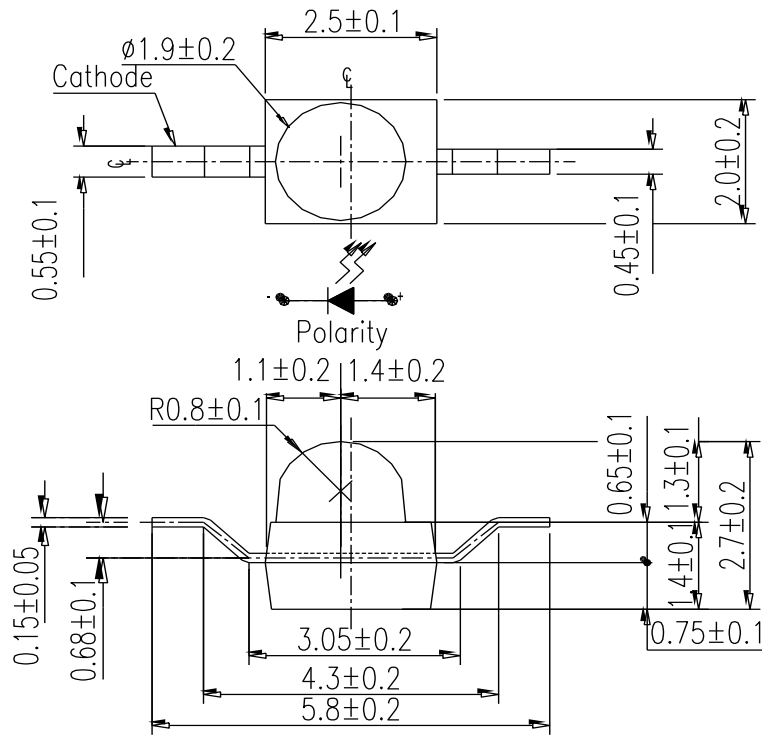

91-21F10/TR10

Note:Unit=mm

Note: The tolerances unless mentioned are  $\pm 0.1$ , unit=mm

## Moisture Resistant Packing Materials

### Label Explanation



**EVERLIGHT**
5

CPN: XXXXXXXXXXXXXXXXXXXXXXXX  
 XXXXXXXXXXXX-XXXXXXXXXX-XXXXXXXXXX-XXXXXXXXXX-XXXXXX  
 P/N: XXXXXXXXXXXX  
 XXXXXXXXXXXX-XXXXXXXXXX-XXXXXXXXXX-XXXXXXXXXX-XXXXXX  
 LOT NO: Y150716XXX-XXXXXXXXXX-XXXXXXXXXX  
 QTY: 0123456789 HUE: XXXXXXXXXXXX  
 CAT: XXXXXXXXXXXX REF: XXXXXXXXXXXX  
 REFERENCE: BTPYYMDDXXXXX  
 MSL-X                      MADE IN XXXXXX

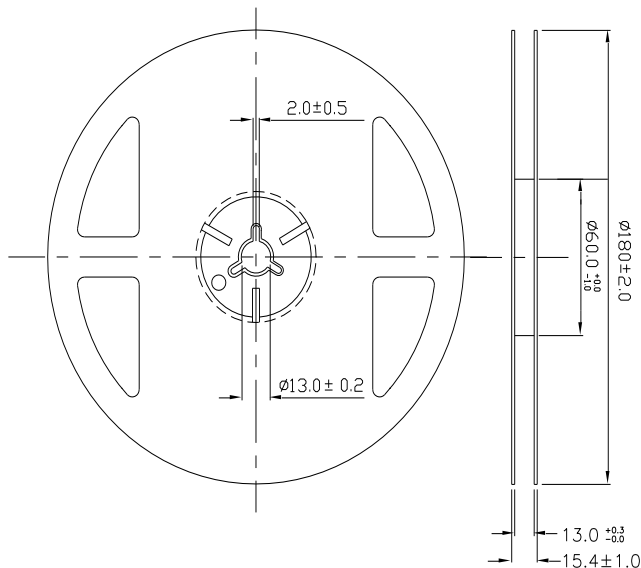

- CPN: Customer's Product Number
- P/N: Product Number
- LOT No: Lot Number
- QTY: Packing Quantity
- CAT: Luminous Intensity Rank
- HUE: Dom. Wavelength Rank
- REF: Forward Voltage Rank

## Reel & Carrier Tape Dimensions



Note: The tolerances unless mentioned are  $\pm 0.1$ , unit=mm

Loaded quantity 1000 PCS per reel

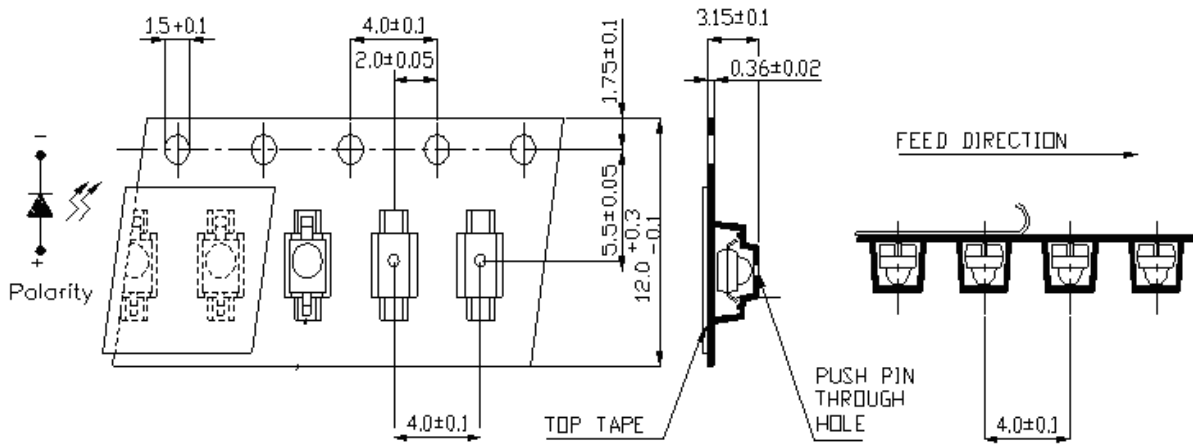

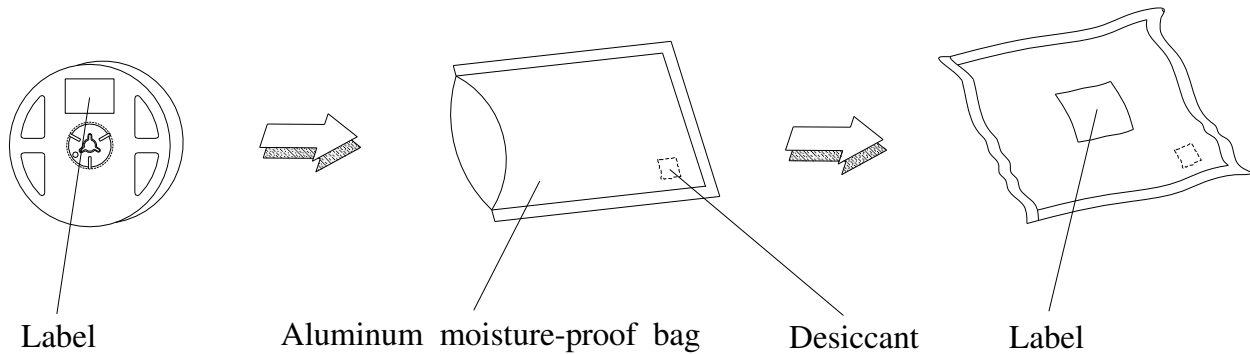

## Precautions For Use

### 1. Over-current-proof

Customer must apply resistors for protection, otherwise slight voltage shift will cause big current change ( Burn out will happen ).

### 2. Storage

2.1 Do not open moisture proof bag before the products are ready to use.

2.2 Before opening the package: The LEDs should be kept at 30°C or less and 90%RH or less.

2.3 After opening the package: The LED's floor life is 72 hours under 30°C or less and 60% RH or less.

If unused LEDs remain, it should be stored in moisture proof packages.

2.4 If the moisture absorbent material (silica gel) has faded away or the LEDs have exceeded the storage time, baking treatment should be performed using the following conditions.

Baking treatment : 60±5°C for 24 hours.

### 3. Soldering Condition

#### 3.1 Pb-free solder temperature profile

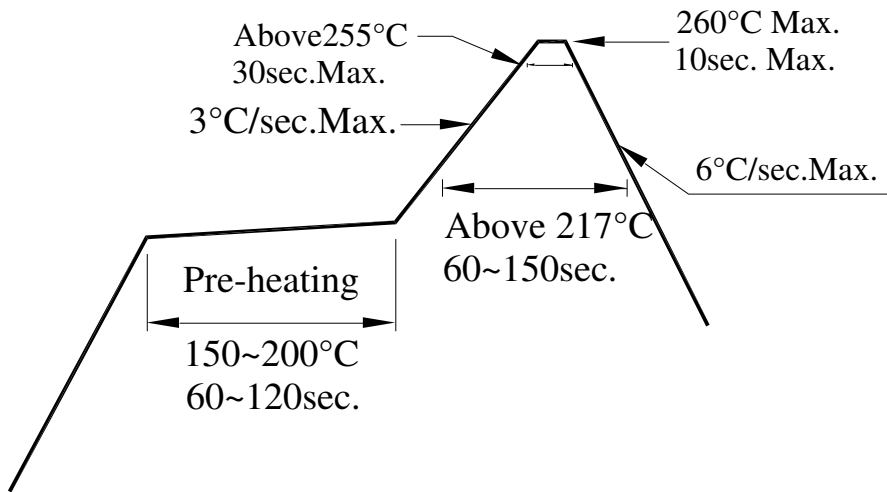

3.2 Reflow soldering should not be done more than two times.

3.3 When soldering, do not put stress on the LEDs during heating.

3.4 After soldering, do not warp the circuit board.

#### 4. Soldering Iron

Each terminal is to go to the tip of soldering iron temperature less than 350°C for 3 seconds within once in less than the soldering iron capacity 25W. Leave two seconds and more intervals, and do soldering of each terminal. Be careful because the damage of the product is often started at the time of the hand solder.

#### 5. Repairing

Repair should not be done after the LEDs have been soldered. When repairing is unavoidable, a double-head soldering iron should be used (as below figure). It should be confirmed beforehand whether the characteristics of the LEDs will or will not be damaged.

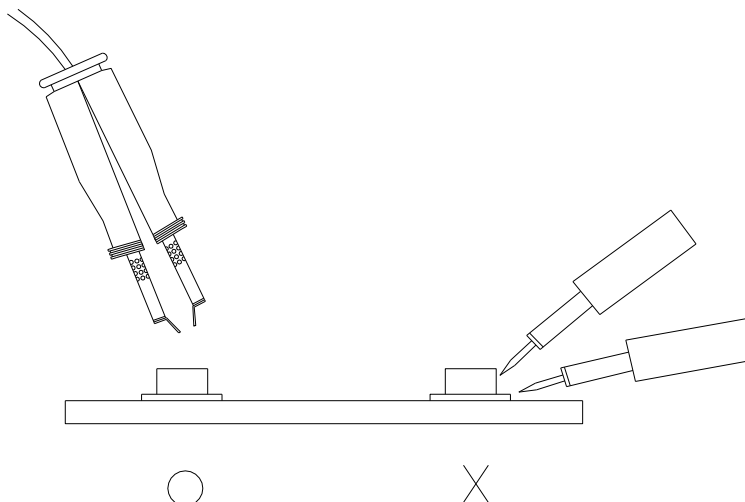



## DISCLAIMER

1. EVERLIGHT reserves the right(s) on the adjustment of product material mix for the specification.
2. The product meets EVERLIGHT published specification for a period of twelve (12) months from date of shipment.
3. The graphs shown in this datasheet are representing typical data only and do not show guaranteed values.
4. When using this product, please observe the absolute maximum ratings and the instructions for using outlined in these specification sheets. EVERLIGHT assumes no responsibility for any damage resulting from the use of the product which does not comply with the absolute maximum ratings and the instructions included in these specification sheets.
5. These specification sheets include materials protected under copyright of EVERLIGHT. Reproduction in any form is prohibited without obtaining EVERLIGHT's prior consent.
6. This product is not intended to be used for military, aircraft, automotive, medical, life sustaining or life saving applications or any other application which can result in human injury or death. Please contact authorized Everlight sales agent for special application request.