

SERIES: PRQ100W-D | **DESCRIPTION:** DC-DC CONVERTER

FEATURES

- 100W isolated output
- ¼-Brick package with industry standard pin-out
- ultra-wide input voltage range
- single regulated output
- high efficiency up to 94%
- output short circuit, over current, over voltage, & over temperature protection
- 2250 Vdc isolation
- EN 62368 approved
- available with heat sink or base plate
- CTRL pin



MODEL	input voltage		output voltage	output current	output power	ripple & noise ¹ Vo1/Vo2	efficiency ²
	max (Vdc)	range (Vdc)	(Vdc)	max (A)	max (W)	max (mVp-p)	min/typ (%)
PRQ100W-Q24-S5 ³	40	9~36	5	20	100	250	87/89
PRQ100W-Q24-S12 ³	40	9~36	12	8.3	100	200	88/90
PRQ100W-Q24-S15 ³	40	9~36	15	6.7	100	200	88/90
PRQ100W-Q24-S24 ³	40	9~36	24	4.2	100	250	88/90
PRQ100W-Q24-S48 ³	40	9~36	48	2.1	100	250	88/90
PRQ100W-Q48-S5	80	18~75	5	20	100	250	91/93
PRQ100W-Q48-S12	80	18~75	12	8.3	100	200	91/93
PRQ100W-Q48-S15	80	18~75	15	6.7	100	200	92/94
PRQ100W-Q48-S24	80	18~75	24	4.2	100	250	91/93
PRQ100W-Q48-S48	80	18~75	48	2.1	100	250	91/93

Notes:
 1. 20MHz bandwidth, nominal input, full load
 2. Efficiency is measured with 24 V input voltage and rated output load.
 3. Model is not CE certified.

PART NUMBER KEY

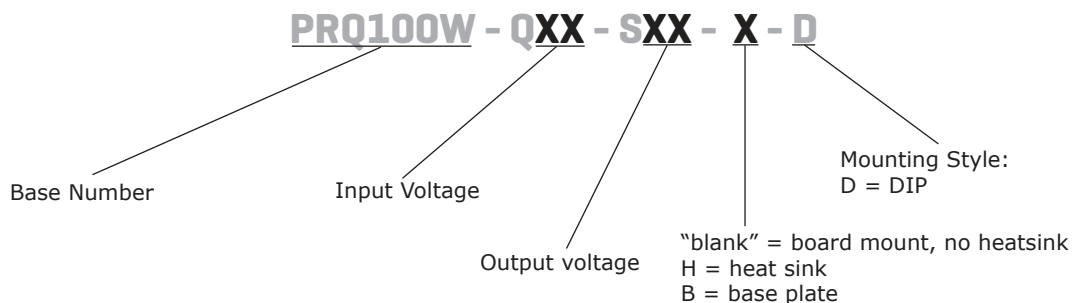

INPUT

parameter	conditions/description	min	typ	max	units
operating input voltage		9	24	40	Vdc
start-up voltage				9	Vdc
surge voltage	for maximum of 1 second	-0.7		50	Vdc
current	full load / no load				
	24 Vdc input models		4.68/0.12	4.79/0.16	A
	48 Vdc input models		2.26/0.05	2.34/0.08	A
filter	Pi filter				
CTRL	module on: CTRL open or pulled high (3.5~12 V) module off: CTRL pulled low to GND (0~1.2 V)				

OUTPUT

parameter	conditions/description	min	typ	max	units
maximum capacitive load	output voltage				
	5 Vdc			6,000	μF
	12 Vdc & 15 Vdc			2,000	μF
	24 Vdc			1,000	μF
	48 Vdc			470	μF
voltage accuracy	0% to full load			±3	%
line regulation	from low line to high line, full load			±0.5	%
load regulation	5% to full load			±0.75	%
switching frequency	PWM mode		250		kHz
transient recovery time	25% load step change, nominal input voltage		200	500	μs
transient response deviation	25% load step change, nominal input voltage		±3	±5	%
temperature coefficient	at full load			±0.03	%/°C
adjustability	see trim resistor connection			±10	%
remote sense	see remote sense application circuit			110	%Vo

PROTECTIONS

parameter	conditions/description	min	typ	max	units
over voltage protection		110		160	%
over current protection		110		150	%
short circuit protection	continuous, auto recovery, hiccup				

SAFETY AND COMPLIANCE

parameter	conditions/description	min	typ	max	units
isolation voltage	input to output	2,250			Vdc
	input to case	1,600			Vdc
	output to case	500			Vdc
isolation resistance	input to output at 500 Vdc	100			MΩ
isolation capacitance	input to output, 100 kHz / 0.1 V		2,200		pF
safety approvals	certified to	62368-1: EN, BS EN			
	designed to meet	62368-1: UL (Q24 models only)			
	designed to meet	50155: EN (Q24 models only)			
EMI/EMC	CISPR 32/EN 55032 Class A & Class B (see the recommended circuit)				
conducted emissions	EN50121-3-2 150kHz-500kHz 99dBuV, EN55016-2-1 500kHz-30MHz 93dBuV				
radiated emissions	EEN50121-3-2 30MHz-230MHz 40dBuV/m at 10m, EN55016-2-1 230MHz-1GHz 47dBuV/m at 10m				
ESD	IEC/EN 61000-4-2 Contact ±6KV/Air ±8KV, perf. Criteria B				
	EN 50121-3-2 Contact ±6KV/Air ±8KV				
radiated immunity	IEC/EN 61000-4-3 20 V/m, perf. Criteria A, EN50121-3-2 80MHz-800MHz 20V/m(rms)				
EFT/burst	IEC/EN 61000-4-4 ±2KV (see the recommended circuit), perf. Criteria A EN 50121-3-2 ±2kV 5/50ns 5kHz				
surge	EN 50121-3-2 line to line ±1KV (42Ω 0.5uF see the recommended circuit)				
conducted immunity	IEC/EN 61000-4-6 10 Vr.m.s, perf. Criteria A, EN50121-3-2 0.15MHz-80MHz 10Vr.m.s				
MTBF	as per MIL-HDBK-217F, 25°C	500			K hours
RoHS	yes				

ENVIRONMENTAL

parameter	conditions/description	min	typ	max	units
operating temperature	see derating curve	-40		85	°C
storage temperature		-55		125	°C
storage humidity	non-condensing	5		95	%

MECHANICAL

parameter	conditions/description	min	typ	max	units
dimensions	61.8 × 40.2 × 12.7 [2.43 × 1.58 × 12.5 inch]				mm
	with base plate 62.0 × 56.0 × 14.6 [2.44 × 2.2 × 0.57 inch]				mm
	with heat sink 61.8 × 40.2 × 27.7 [2.43 × 1.58 × 1.09 inch]				mm
case material	aluminum alloy				
weight			86		g
	with base plate		106		g
	with heat sink		117		g

MECHANICAL DRAWING

units: mm [inch]

pin 1, 2, 3, 5, 6, 7's diameter: 1.00 [0.039]

pin 4, 8's diameter: 1.50 [0.059]

pin diameter tolerance: ±0.10 [±0.004]

general tolerance: ±0.50[±0.020]

mounting hole screwing torque: Max 0.4 N·m

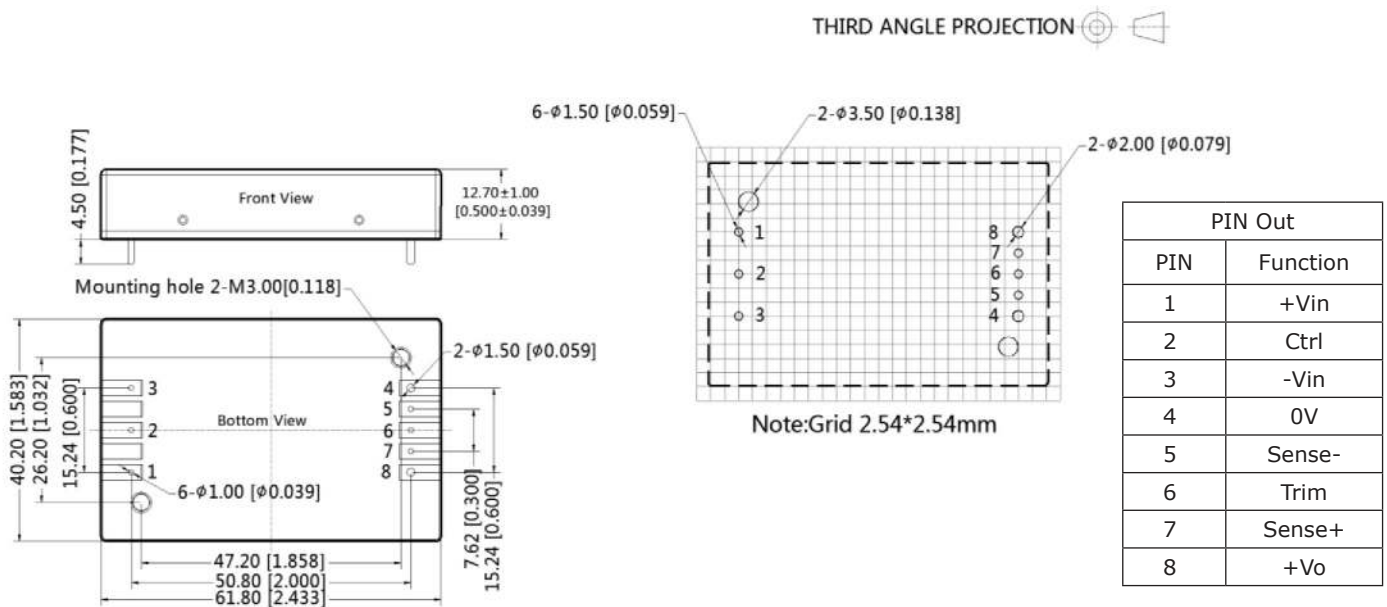

MECHANICAL DRAWING

units: mm [inch]

pin 1, 2, 3, 5, 6, 7's diameter: 1.00 [0.039]

pin 4, 8's diameter: 1.50 [0.059]

pin diameter tolerance: ± 0.10 [± 0.004]

general tolerance: ± 0.50 [± 0.020]

mounting hole screwing torque: Max 0.4 N·m

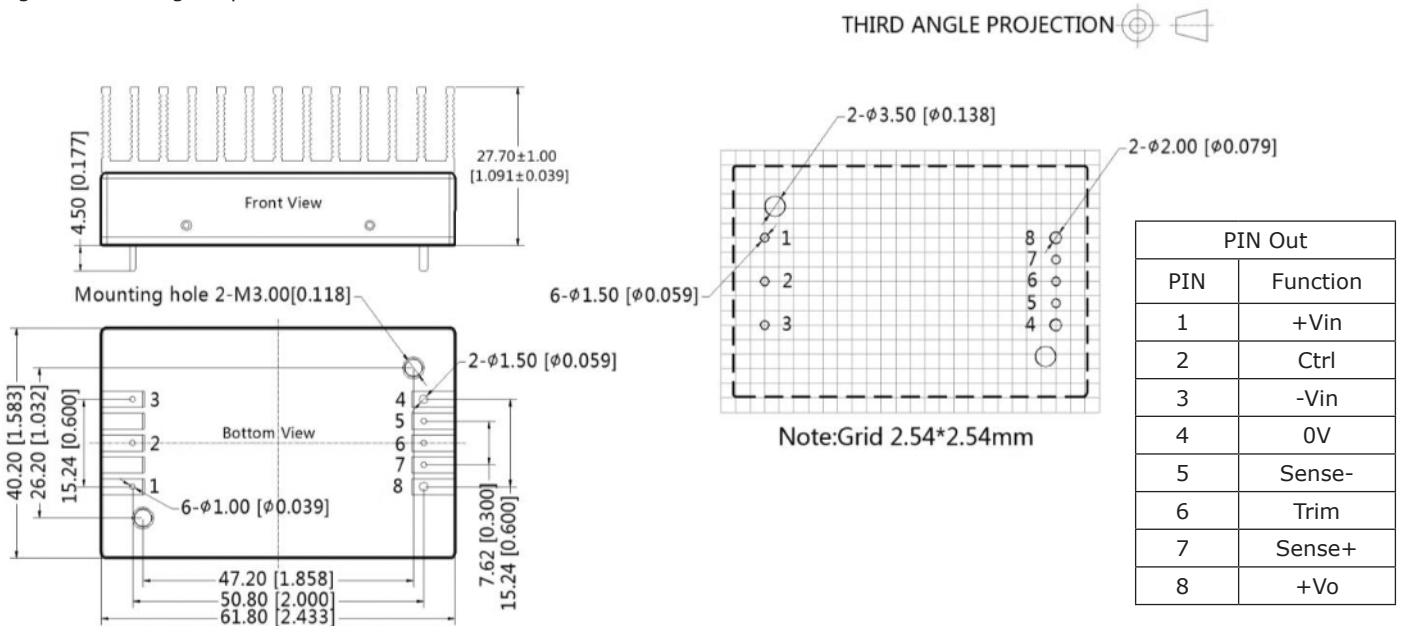

units: mm [inch]

pin 1, 2, 3, 5, 6, 7's diameter: 1.00 [0.039]

pin 4, 8's diameter: 1.50 [0.059]

pin diameter tolerance: ± 0.10 [± 0.004]

general tolerance: ± 0.50 [± 0.020]

mounting hole screwing torque: Max 0.4 N·m

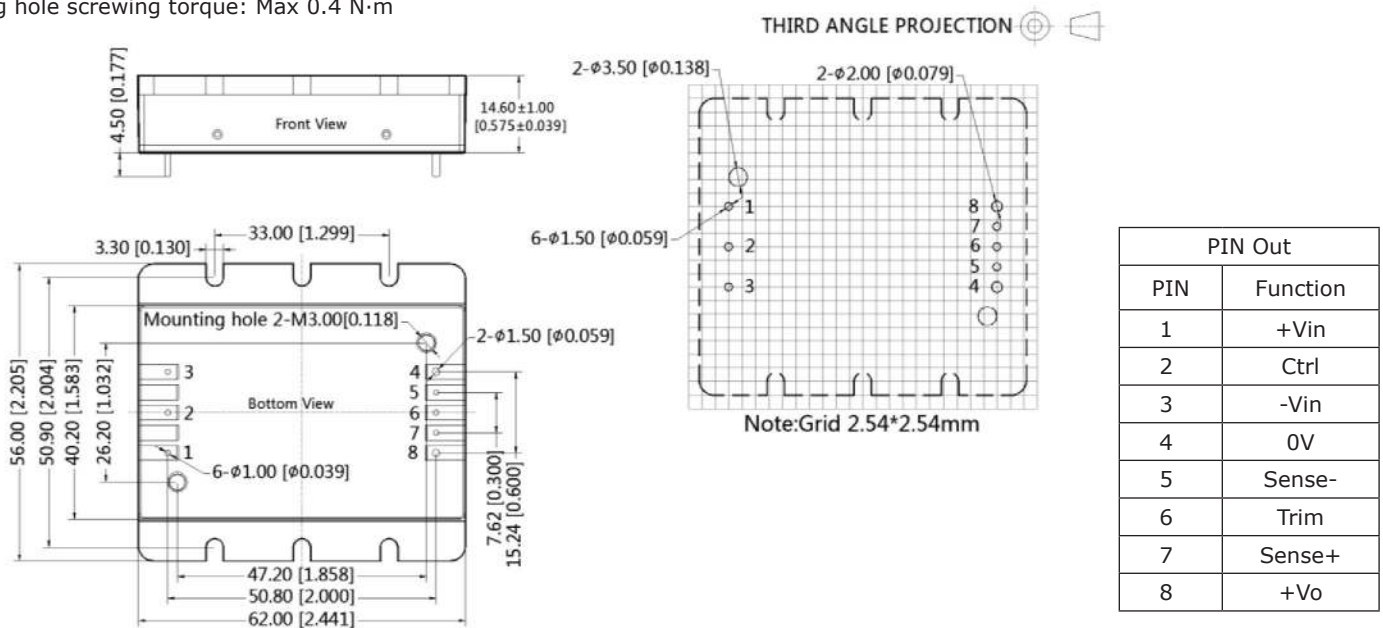

DERATING CURVES

**TEMPERATURE DERATING CURVE ($V_{in} = 24\text{ V}$)
PRQ100W-Q24-D**

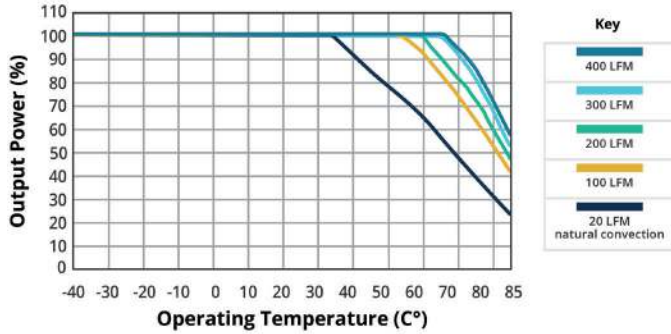

**TEMPERATURE DERATING CURVE ($V_{in} = 24\text{ V}$)
PRQ100W-Q24-B-D (Base plate version)**

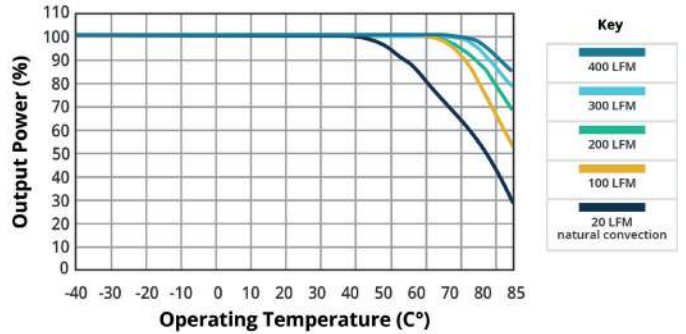

**TEMPERATURE DERATING CURVE ($V_{in} = 24\text{ V}$)
PRQ100W-Q24-H-D (Heatsink version)**

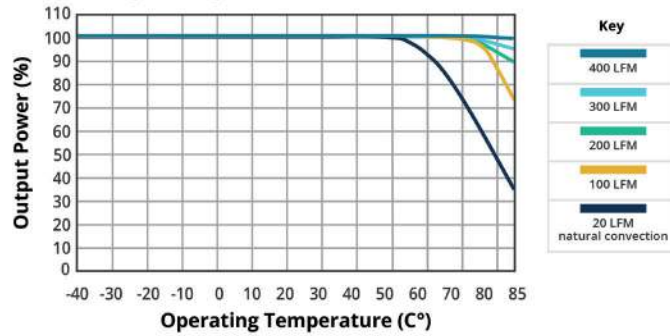

APPLICATION CIRCUIT

Figure 1

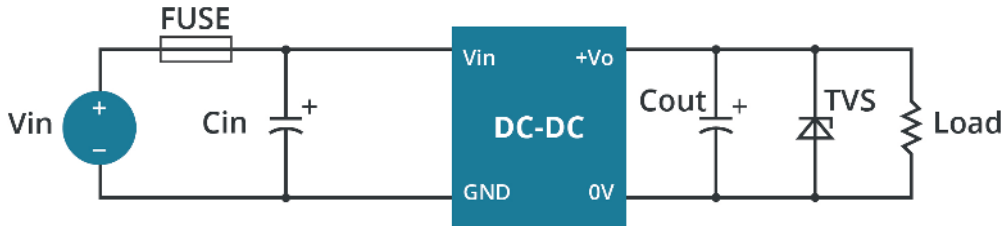

Table 1

Vout (Vdc)	Fuse	Cin	Cout	TVS
24	20A slow blow	220 μ F	100 μ F	SMDJ30A
48				SMDJ64A

EMC RECOMMENDED CIRCUIT

Figure 2

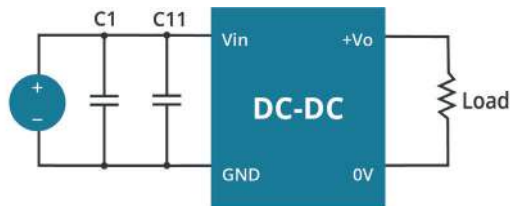

Table 2

Capacitor	Recommended value	Function
C1	150 μ F electrolytic capacitor	Meets EFT and surge
C11	47 μ F electrolytic capacitor	

Figure 3

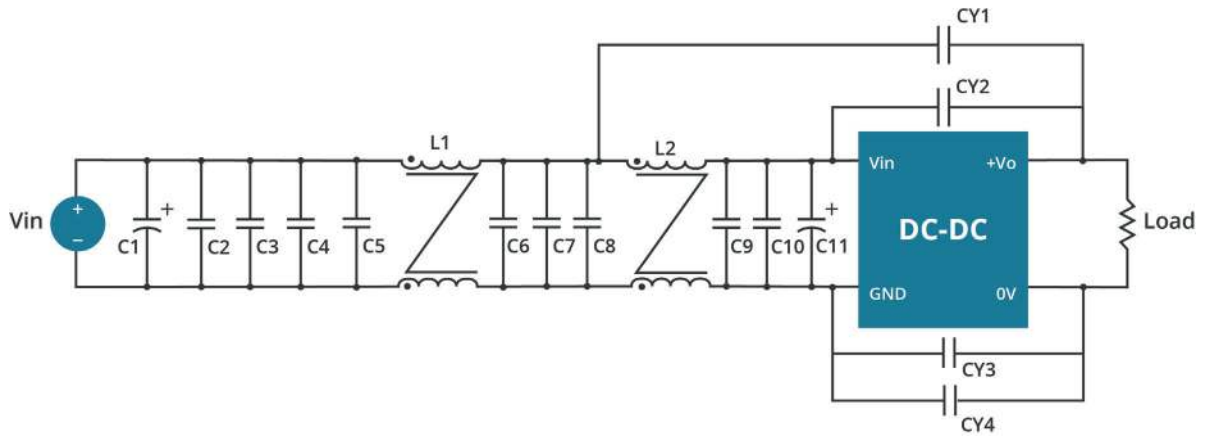

Table 3

Class A components	Class B components	Recommended component value	Function
	C1	150 μ F electrolytic capacitor	Meets conducted emission and radiated emission
	C11	47 μ F electrolytic capacitor	
	C2, C3, C4, C5, C6, C7, C8, C9, C10	10 μ F ceramic capacitor	
	L1, L2	1.6mH common mode inductor	
CY3	CY1, CY2	2.2nF Y1 safety capacitor	
	CY3, CY4	1nF Y1 safety capacitor	

TRIM RESISTOR CONNECTION

Figure 4

Trim up

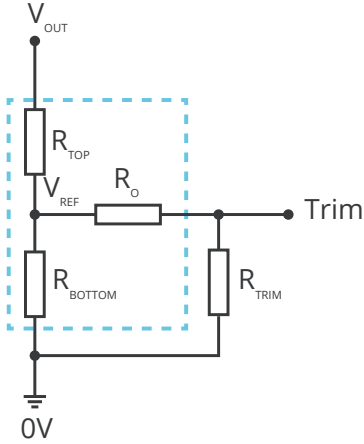

Trim down

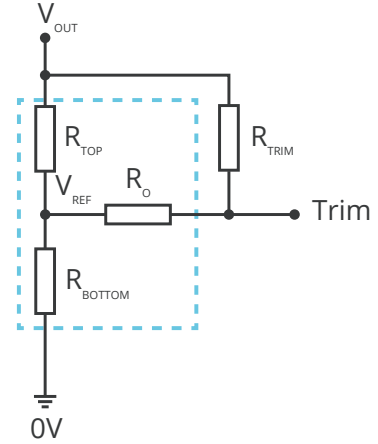

$$R_{TRIM} = \frac{a \cdot R_{BOTTOM}}{R_{BOTTOM} - a} - R_O \quad a = \frac{V_{REF}}{V_{OUT} - V_{REF}} \cdot R_{TOP}$$

Formula for Trim up

$$R_{TRIM} = \frac{a \cdot R_{TOP}}{R_{TOP} - a} - R_O \quad a = \frac{V_{OUT} - V_{REF}}{V_{REF}} \cdot R_{BOTTOM}$$

Formula for Trim down

Table 4

V_{NOM}	R_{TOP}	R_{BOTTOM}	R_O	V_{REF}
(Vdc)	(kΩ)	(kΩ)	(kΩ)	(V)
24	24.872	2.87	15	2.5
48	53.017	2.894	15	2.5

Note: Value for R_{TOP} , R_{BOTTOM} , R_O , and V_{REF} refer to Table 4 (fixed internal values).

R_{TRIM} : Trim resistance

a: User-defined parameter, no actual meanings

V_{NOM} : Nominal output voltage

V_{OUT} : Target output voltage

REMOTE SENSE APPLICATION

Figure 5

**REMOTE SENSE CONNECTION
IF NOT USED**

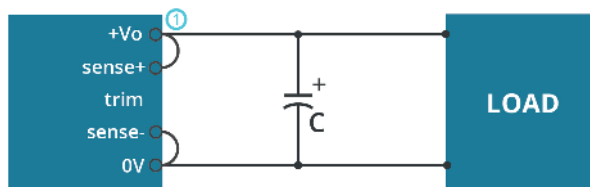

- Note:
1. Lines must be kept as short as possible.
 2. If the sense function is not used for remote regulation the user must connect the +Sense to +Vo and -Sense to 0V at the dc-dc converter pins and will compensate for voltage drop across pins only.
 3. The connections between Sense lines and their respective power lines must be kept as short as possible, otherwise they may be picking up noise, interference and /or causing unstable operation of the power module.

Figure 6

**REMOTE SENSE CONNECTION
USED FOR COMPENSATION**

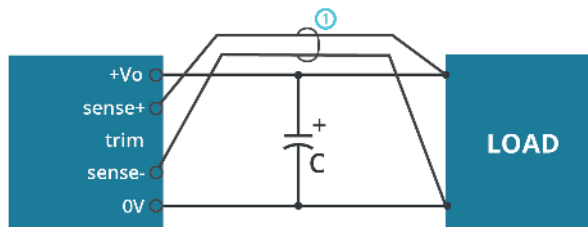

- Note:
1. In cables and discrete wiring applications, twisted pair or other techniques should be implemented.
 2. Using remote sense with long wires may cause unstable operation. Note that large wire impedance may cause oscillation of the output voltage and/or increased ripple. Consult technical support or factory for further advice of sense operation.
 3. We recommend using adequate cross section for PCB-track layout and/or cables to connect the power supply module to the load in order to keep the voltage drop below 0.3V and to make sure the power supply's output voltage remains within the specified range.

REVISION HISTORY

rev.	description	date
1.0	initial release	09/03/2020
1.01	derating curves and circuit figures updated	09/06/2021
1.02	input current updated	02/15/2022
1.03	CE certification for 24V model updated, UKCA mark added	10/25/2022
1.04	output voltage trimming updated	05/30/2023

The revision history provided is for informational purposes only and is believed to be accurate.



Headquarters
20050 SW 112th Ave.
Tualatin, OR 97062
800.275.4899

Fax 503.612.2383
cui.com
techsupport@cui.com

CUI offers a two (2) year limited warranty. Complete warranty information is listed on our website.

CUI reserves the right to make changes to the product at any time without notice. Information provided by CUI is believed to be accurate and reliable. However, no responsibility is assumed by CUI for its use, nor for any infringements of patents or other rights of third parties which may result from its use.

CUI products are not authorized or warranted for use as critical components in equipment that requires an extremely high level of reliability. A critical component is any component of a life support device or system whose failure to perform can be reasonably expected to cause the failure of the life support device or system, or to affect its safety or effectiveness.