

Customer Information Sheet

DRAWING No.: S1001-46R

IF IN DOUBT - ASK

©

NOT TO SCALE

THIRD ANGLE PROJECTION

ALL DIMENSIONS IN mm

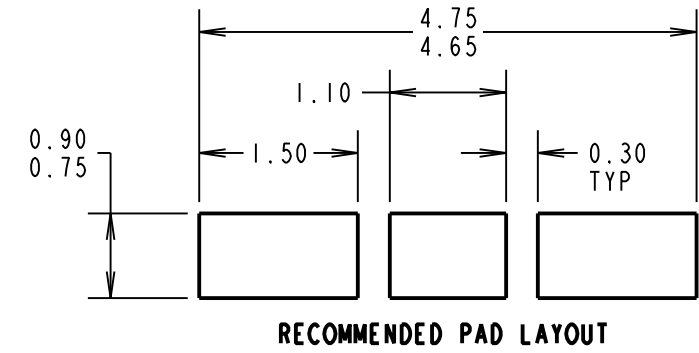
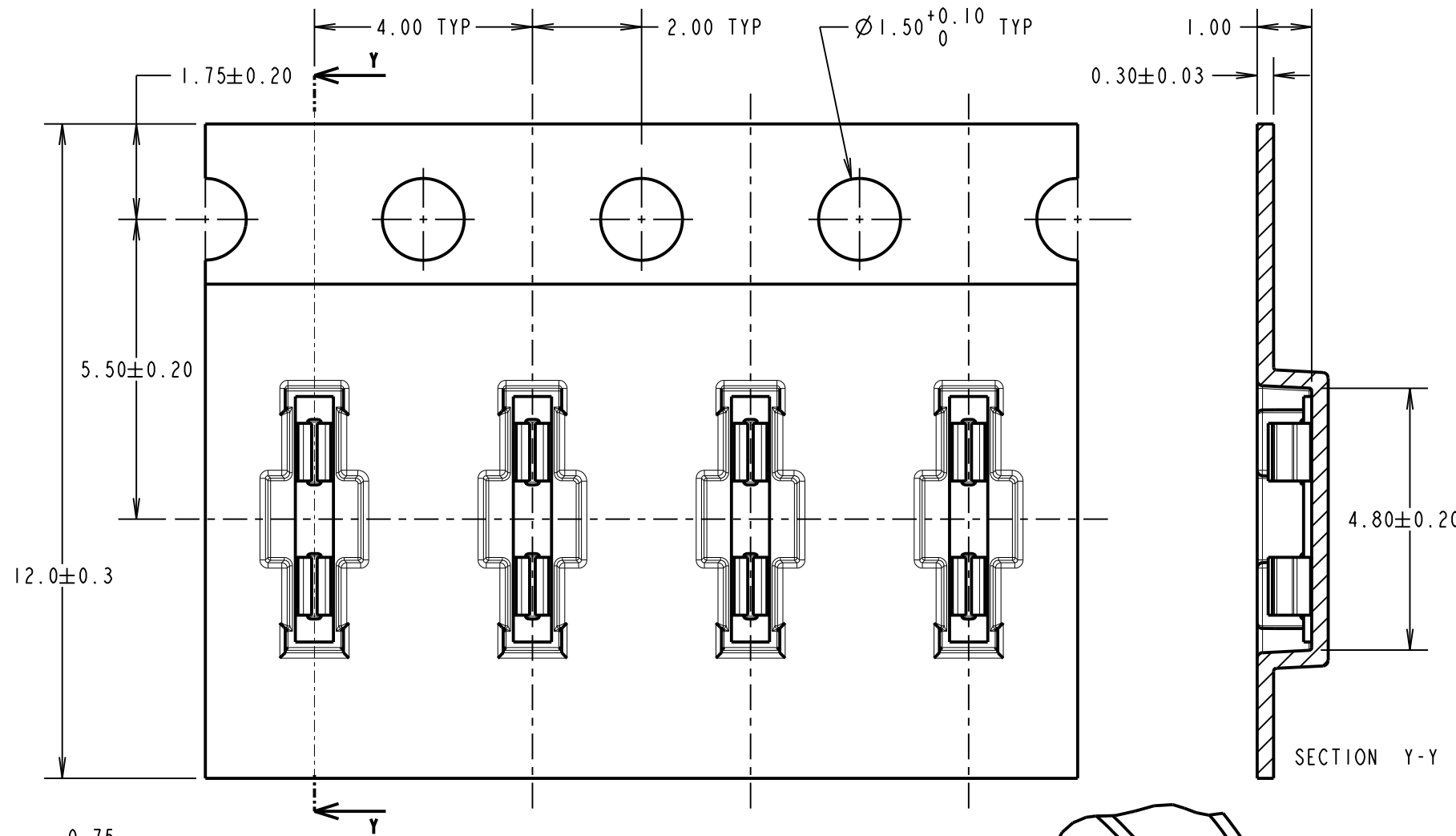

RECOMMENDED SHIELD CAN CUT OUT

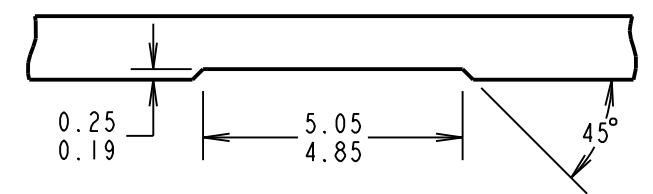

SPECIFICATION:
MATERIAL:
 CONTACT = STAINLESS STEEL
ELECTRICAL:
 RESISTANCE = 100mΩ MAX
MECHANICAL:
 INSERTION FORCE = 19.7N MAX
 WITHDRAWAL FORCE = 0.98N MIN
 DURABILITY = 10 CYCLES
ENVIRONMENTAL:
 OPERATING TEMPERATURE = -40°C TO +150°C
 STORAGE TEMPERATURE = -40°C TO 85°C
PACKAGING:
 TAPE AND REEL PACKED IN BOX

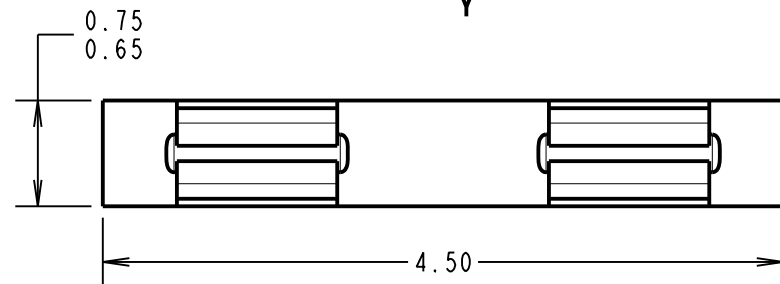

COMPONENT DETAILS

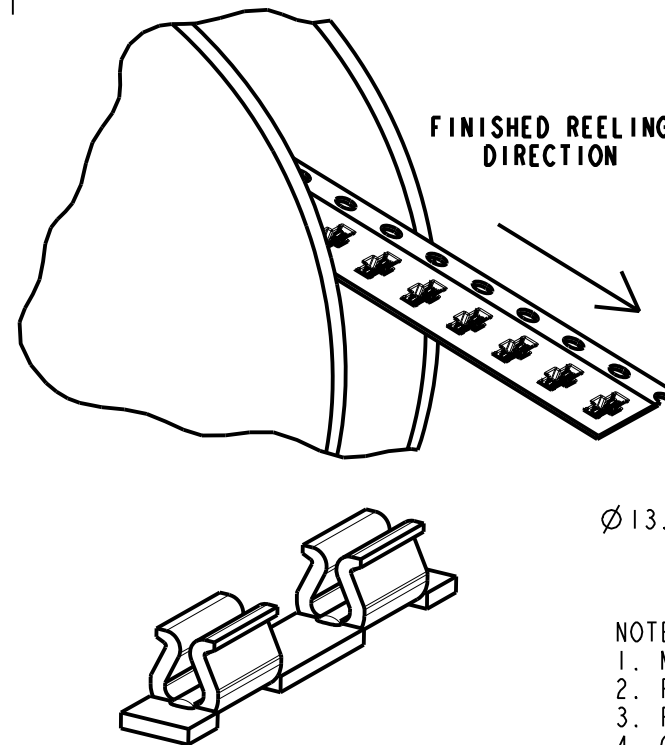
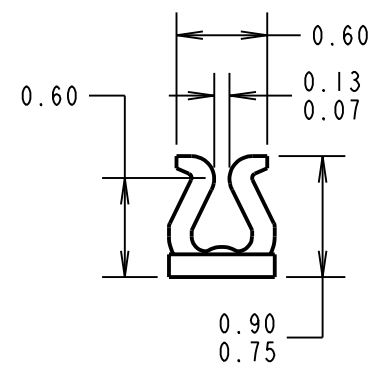
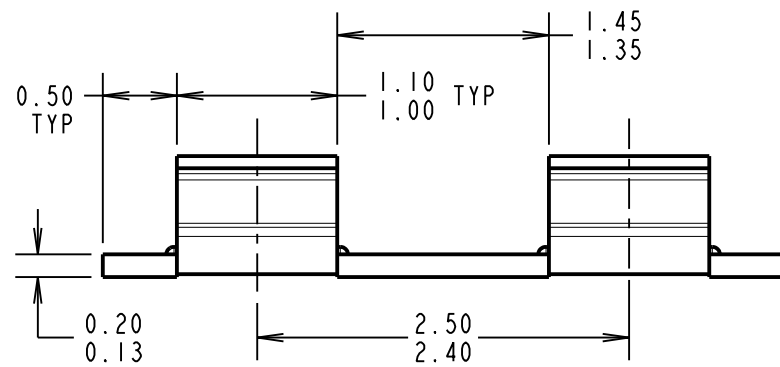

FINISHED REELING DIRECTION

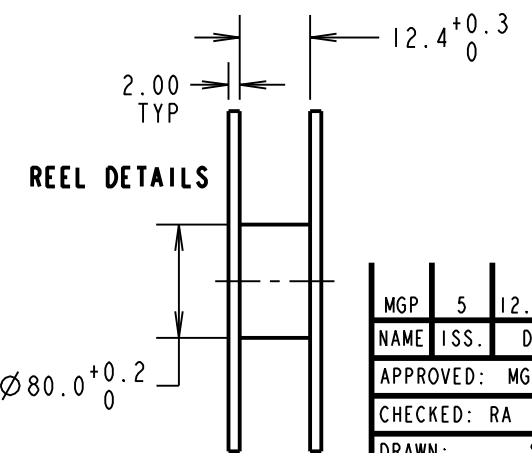
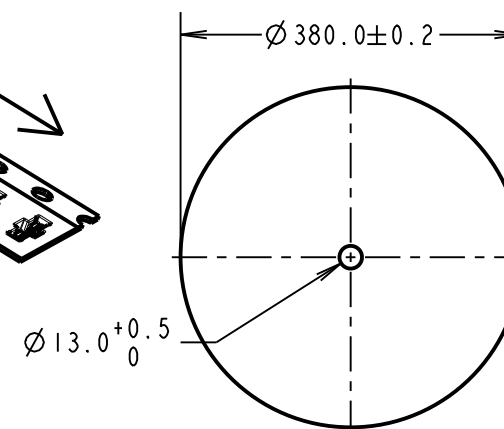

REEL DETAILS

- NOTES:**
1. MAXIMUM PERMISSIBLE BURR IS 0.03mm MAX.
 2. FINISH = 2.0µm - 3.0µm TIN OVER 0.4µm - 1.2µm NICKEL.
 3. FOR USE WITH 0.15 - 0.20mm THICK SHIELD CANS.
 4. QUANTITY PER REEL = 20,000. 11 REELS PACKED IN BOX.

MGP	5	12.01.22	31219
NAME	ISS.	DATE	CN/CO
APPROVED: MGP			
CHECKED: RA			
DRAWN: S.BENNETT			
CUSTOMER REF.:			
ASSEMBLY DRG:			

HARWIN

www.harwin.com
 technical@harwin.com

THIS DRAWING AND ANY INFORMATION OR DESCRIPTIVE MATTER SET OUT HEREON ARE CONFIDENTIAL AND COPYRIGHT PROPERTY OF THE HARWIN GROUP AND MUST NOT BE DISCLOSED, LOANED, COPIED OR USED FOR MANUFACTURING, TENDERING OR FOR ANY OTHER PURPOSE WITHOUT THEIR WRITTEN PERMISSION.

TOLERANCES
 X. = ±1mm
 X.X = ±0.50mm
 X.XX = ±0.20mm
 X.XXX = ±0.01mm
 ANGLES = ±5°
 UNLESS STATED

MATERIAL:
 SEE ABOVE
FINISH:
 SEE ABOVE
S/AREA:
 mm²

TITLE:
 SURFACE MOUNT RFI
 SHIELD CLIP IN TAPE AND REEL

DRAWING NUMBER:
 S1001-46R

SHT
 2 OF 2