

THIS DOCUMENT IS THE PROPERTY OF  
KEYSTONE ELECTRONICS CORP. AND  
SHALL NOT BE REPRODUCED, DISTRIBUTED  
OR USED AS A BASIS FOR MANUFACTURE  
WITHOUT PRIOR WRITTEN PERMISSION  
FROM KEYSTONE ELECTRONICS CORP.

ACTUAL SIZE

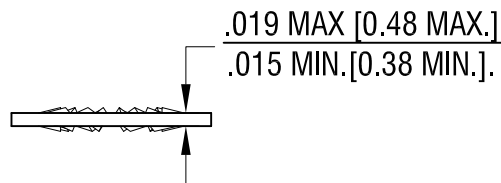
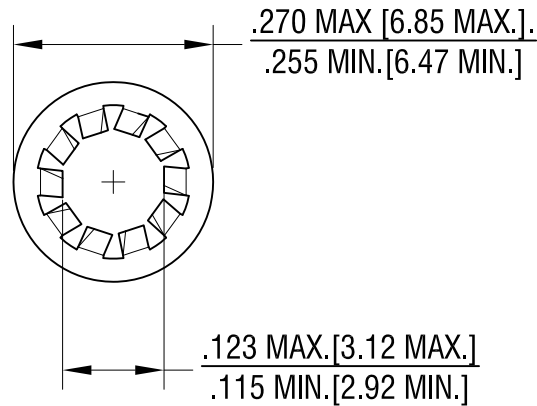

**KEYSTONE ELECTRONICS CORP.**

www.keyelco.com • ASTORIA, N.Y. 11105-2017 • Tel (718) 956-8900

PART NAME

INTERNAL TOOTH LOCKWASHER

MATERIAL

PHOSPHOR BRONZE

FINISH

NICKEL PLATE

DRN BY

NT

DATE

1.25.08

APP'D

LN

SCALE

4X

TOLERANCES

INCH [MM]

DECIMAL  $\pm .005$  [ $\pm 0.13$ ]

ANGULAR  $\pm 1^\circ$

UNLESS OTHERWISE SPECIFIED

CODE

C

DWG NO.

11360-4

DATE	DESCRIPTION	REV.