

General Features

- High Performance, Low Power AVR® 8-Bit Microcontroller
- Advanced RISC Architecture
 - 131 Powerful Instructions - Most Single Clock Cycle Execution
 - 32 x 8 General Purpose Working Registers
 - Up to 16MIPS Throughput at 16Mhz
 - On-chip 2-cycle Multiplier
- Non-volatile Program and Data Memories
 - 64K Bytes of In-System Self-Programmable Flash
 - Endurance: 10,000 Write/Erase Cycles
 - 4K Bytes EEPROM
 - Contains 128 Bytes of One Time Programmable Memory
 - Endurance: 100,000 Write/Erase Cycles
 - 4K Bytes Internal SRAM
 - Optional Boot Code Section
 - In-System Programming by On-chip Bootloader program
- JTAG (IEEE std. 1149.1 compliant) Interface
 - Boundary-scan Capabilities According to the JTAG Standard
 - Extensive On-chip Debug Support
 - Programming of Flash, EEPROM, Fuses, and Locks Bits through JTAG Interface
 - Locking JTAG for Software Security (using OTP programming)
- ISO7816 UART Interface Fully compliant with EMV, GIE-CB and WHQL Standards
 - Programmable ISO clock from 1 Mhz to 4.8, 6, 8 or 12Mhz
 - Card insertion/removal detection with automatic deactivation sequence
 - Programmable Baud Rate Generator from 372 to 3 clock cycles
 - Synchronous/Asynchronous Protocols T=0 and T=1 with Direct or Inverse Convention
 - Automatic character repetition on parity errors
 - 32 Bit Waiting Time Counter
 - 16 Bit Guard Time Counter/Block Guard Time Counter
 - Internal Step Up/Down Converter with Programmable Voltage Output if DC/DC embedded:
 - Class A: 5V +/-8% at 60mA, Vcc>2.85 (50mA if Vcc >2.7)
 - Class B: 3V +/-8% at 60mA, Vcc>2.85 (50mA if Vcc >2.7)
 - Class C: 1.8V +/-8% at 35mA
 - ISO7816-12 USB Host controller for card interface
 - Supports up to 60mA USB Smart Cards
 - Supports limited cable length to Smart Card Connector (~50cm)
 - 4 kV ESD (MIL/STD 833 Class 3) protection on whole Smart Card Interface
- USB 2.0 Full-speed Device Module
 - Complies fully with:
 - Universal Serial Bus Specification Rev 2.0
 - Supports data transfer rates up to 12 Mbit/s
 - Endpoint 0 for Control Transfers : up to 64-bytes
 - 8 Programmable Endpoints with IN or OUT Directions and with Bulk, Interrupt or Isochronous Transfers
 - 3 Programmable Endpoints with double buffering of 64x2 bytes
 - Suspend/Resume Interrupts, and Remote Wake-up Support
 - Power-on Reset and USB Bus Reset



8-bit AVR® Microcontroller for Smart Card Readers

AT90SCR100

Summary Preliminary

6568AX-SMS-23Oct08



SUMMARY PRELIMINARY



- 48 Mhz clock for Full-speed Bus Operation
- USB Bus Disconnection on Microcontroller Request
- Peripheral Features
 - One 8-bit Timer/Counters with Separate Prescaler, Compare Mode and PWM Channel
 - One 8-bit Timer/Counters with Separate Prescaler, Compare Mode and Real Time Counter on Separate Oscillator
 - One 16-bit Timer/Counters with Separate Prescaler and Compare Mode
 - Hardware Watchdog
 - Hardware AES 128/256 Engine
 - Random Number Generator (RNG)
- Communication Peripherals
 - High Speed Master/Slave SPI Serial Interface (Up to 20Mhz)
 - 2-Wire Serial Interface
 - USART interface (up to 2Mbps)
 - Standard SPI Interface (to ease the communication with most of RF front end chip)
- Special Microcontroller Feature
 - Power-on Reset and Brown-out Detection
 - Internal Callibrated Oscillator
 - External and Internal Interrupt Sources
 - Five Sleep Modes: Idle, Power-save, Power-down, Standby and Extended Standby
 - Supply Monitoring with Interruption Generation below a fixed level.
- Keyboard Interface with up to 5x4 Matrix Management Capability + Interrupts and Wake-Up on Key Pressed Event
- Up to 4 x I/O Ports: Programmable I/O Port
- Up to 4 x LED Outputs with Programmable Current Sources: 2 or 4 mA (not usable in emulation mode)
- Specific and Unique Serial Number per IC in production.
- Operating Temperature
 - Industrial (-40°C to +85°C)
- Core Operating Voltages
 - 2.4 - 5.5V
- DC/DC Operating Voltages (See [“Smart Card Interface Characteristics”](#) for details)
 - 2.7 - 5.5V
- Maximum Frequency
 - 8Mhz Clock Input

1. Description

Smart Cards and Smart Card Readers are increasingly being used in various systems such as Health Care, USB Token, Password Generator, Access control, Laptop Computer, Set Topbox, Payment Terminals... These applications require complex integration using different communicating interfaces.

The AT90SCR100 based on the powerful 8/16bit AVR® Core technology, meets the requirements of such applications thanks to its embedded communication interfaces: USB Full-speed, ISO7816 (1-4,12) interface, High Speed SPI supporting speed up to 20Mbps, USART, TWI.

The AT90SCR100 has been designed to support standard systems such as Contactless interface and Fingerchip, among others.

An AES engine is also embedded to ease the development of secured communication between AT90SCR100 and external peripherals.

All these features require a minimum of external components which makes this solution the best choice for low cost high integration in small environments.

Its FLASH memory allows remote firmware management. The JTAG interface eases code development, and program loading in end-customers factories.

A low pincount package is also available for embedded application with size constraints, such as USB tokens, laptop computers.

A complete datasheet will soon be available on Atmel's website: www.atmel.com.

2. Block Diagram

Figure 2-1. Block Diagram

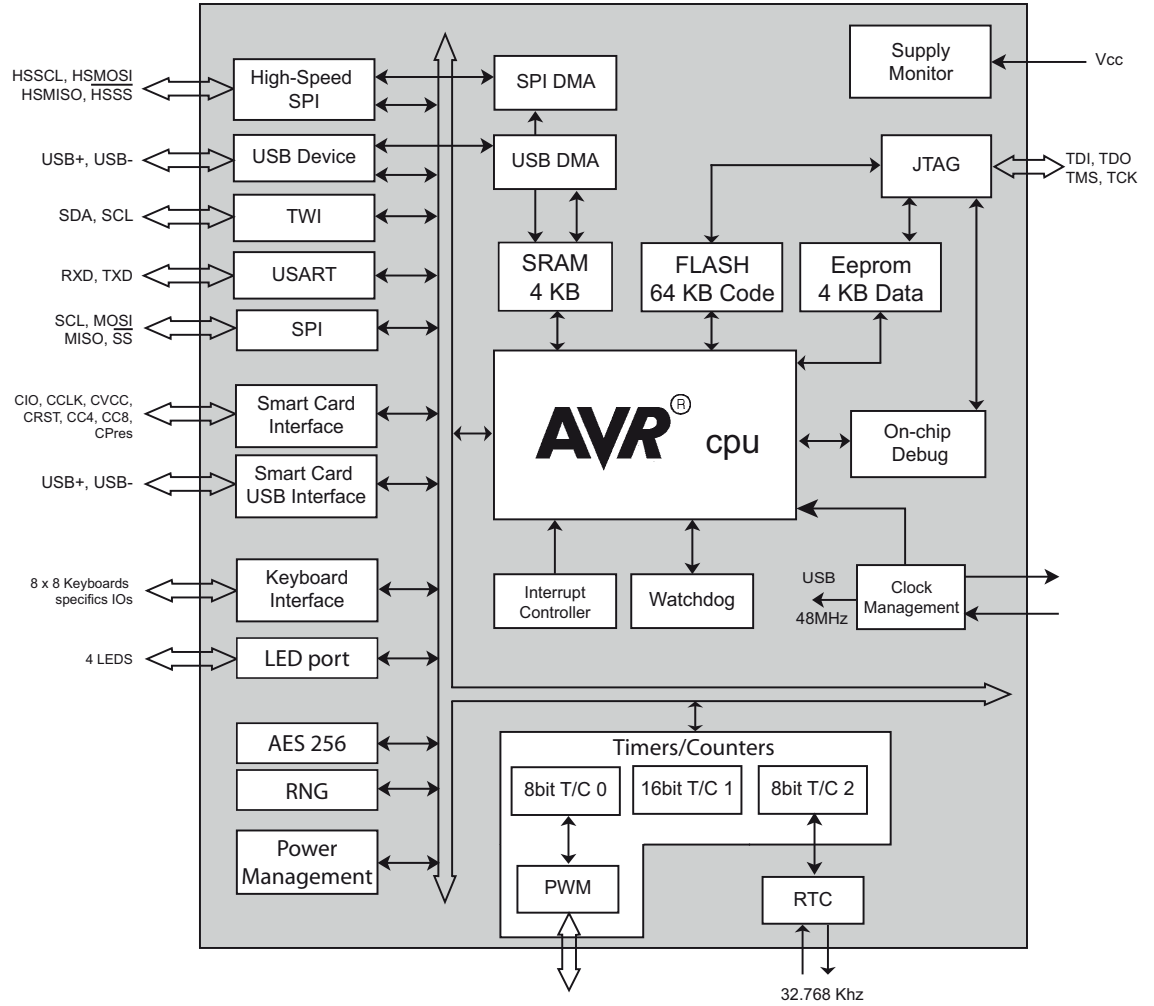

3. Pin List Configuration

- 2 package configurations to answer different needs
 - 32pins: **LowPinCount** package: for small package size, useful for small embedded systems (AT90SCR100L and AT90SCR100LS)
 - 64pins: **FullPinCount**: For full performance advanced reader (AT90SCR100H)



Caution

On Full Pin Count (FPC) package, the only supported package type is QFN, and we connect all the Vss signals to the e-pad. It is important to have it fully soldered on groundplane of final PCB.



Note

- USBReg refers to 3.3V USB specific regulator
- PCINTx refer to Pin Change Interrupts. See “External Interrupt Registers” in full Datasheet.



Caution

Take care of the multiplexed functionalities of each port. All functionalities may be active at the same time. The only way to disable a feature is to deactivate it inside the corresponding peripheral block.

Table 3-1. Pin List Configuration

Portmap	ID	SCR100L	SCR100LS	SCR100H	Supply	Configuration, Role	
Unmapped, generic pins	Vcc	x	x	x	-	Vcc	Voltage Supply
	Vss	x	x	e ⁽¹⁾		Vss	Ground
	AVss	x	x	e ⁽¹⁾		AVss	PLL Ground
	RST	x	x	x	Vcc	RST	Reset signal: Drive low to reinitialize the chip
	Xtal1	x	x	x		XTAL1	Clock Input: Support up to 8 Mhz crystals
	Xtal2	x	x	x		XTAL2	
	DVcc	x	x	x		DVcc	Digital Vcc: Used for internal regulator decoupling
	Vcc2	x	x	x	-	Vcc2	Voltage Supply: To be tied to same Vcc supply voltage
	Vcc3	-	-	x		Vcc3	Voltage Supply: To be tied to same Vcc supply voltage
	Vcc4	-	-	x		Vcc4	Voltage Supply: To be tied to same Vcc supply voltage
	Vcc5	-	-	x		Vcc5	Voltage Supply: To be tied to same Vcc supply voltage
	Vdcdc	x	x	x		Vdcdc	Voltage Supply for DC/DC Converter.
	Vss2	x	x	e ⁽¹⁾		Vss2	Second Vss: To be tied to Vss
	Vss3	x	x	e ⁽¹⁾		Vss3	Third Vss: To be tied to Vss
D+	D+	x	x	x	USB Reg	D+	USB Interface
	D-	x	x	x		D-	
	UCap	x	x	x		UCap	USB Decoupling: Used for specific USB regulator decoupling
RTC1	RTC1	-	-	x	Vcc	TOSC1	TOSCx: 32.768 KHz crystal input for Real Time Clock. (Please note that these pins are not GPIO accessible).
	RTC2	-	-	x		TOSC2	

Table 3-1. Pin List Configuration

Portmap	ID	SCR100L	SCR100LS	SCR100H	Supply	Configuration, Role				
PORT A	PA7	-	-	x	Vcc	KbIN7			PCINT7	KbINx: Input for "Keyboard Interface"
	PA6	-	-	x		KbIN6			PCINT6	
	PA5	-	-	x		KbIN5			PCINT5	
	PA4	-	-	x		KbIN4			PCINT4	
	PA3	-	-	x		KbIN3			PCINT3	
	PA2	-	-	x		KbIN2			PCINT2	
	PA1	-	-	x		KbIN1			PCINT1	
	PA0	-	-	x		KbIN0			PCINT0	
PORT B	PB7	x	-	x	Vcc	SCK	OC2A		PCINT15	SS, MISO, MOSI, SCK: Standard "SPI - Serial Peripheral Interface" OCxx: Output Comparator outputs. See "Timers". ICP1: Input Capture. See "16-bit Timer/Counter1 with PWM" PWM: Output from "8-bit Timer/Counter0 with PWM" Tx: Clock input for "Timers" 0 and 1 XCK: Clock input for synchronous "USART" INTx: "External Interrupts", default configuration CKO: System clock output. (only active if CKOUT fuse is enabled). "Fuse Low Byte".
	PB6	x	-	x		MISO	OC2B		PCINT14	
	PB5	x	-	x		MOSI	OC1A		PCINT13	
	PB4	x	-	x		SS	OC0B		PCINT12	
	PB3	-	-	x		PWM	OC0A		PCINT11	
	PB2	-	-	x			ICP1		PCINT10	
	PB1	-	-	x		INT3	T1	CKO	PCINT9	
	PB0	-	-	x		INT2	T0	XCK	PCINT8	
PORT C ⁽³⁾	PC5	-	-	x	Vcc	JTGTDI	LED3			JTGxxx: "JTAG Interface and On-chip Debug System" SDA, SCL: "2-wire Serial Interface _ TWI" signals LEDx: "LED" Outputs (IO driving current) INTxb: "External Interrupts", bis configuration
	PC4	-	-	x		JTGTD0	LED2			
	PC3	-	-	x		JTGTM5	LED1			
	PC2	x	x	x		JTGTCk	LED0			
	PC1	-	-	x		SDA	INT3b			
	PC0	-	-	x		SCL	INT2b			
PORT D	PD7	-	x	x	Vcc	HSMISO			PCINT23	HSxxxx: "High-Speed SPI Controller" (MISO, MOSI, SCK, SS) INTx: "External Interrupts", default configuration TXD, RXD: "USART" signals OCxB: Output Comparators: See "Timers".
	PD6	-	x	x		HSMOSI			PCINT22	
	PD5	-	x	x		HSSCK			PCINT21	
	PD4	-	x	x		HSSS			PCINT20	
	PD3	-	-	x		INT1			PCINT19	
	PD2	-	-	x		INT0	OC1B		PCINT18	
	PD1	x	x	x		TXD			PCINT17	
	PD0	x	x	x		RXD			PCINT16	

Table 3-1. Pin List Configuration

Portmap	ID	SCR100L	SCR100LS	SCR100H	Supply	Configuration, Role				
PORT E	PE7	-	-	x	Vcc	KbO7			PCINT31	KbOx: Output for "Keyboard Interface"
	PE6	-	-	x		KbO6			PCINT30	
	PE5	-	-	x		KbO5			PCINT29	
	PE4	-	-	x		KbO4			PCINT28	
	PE3	-	-	x		KbO3			PCINT27	
	PE2	-	-	x		KbO2			PCINT26	
	PE1	-	-	x		KbO1			PCINT25	
	PE0	-	-	x		KbO0			PCINT24	
Smart Card PORT	x	x	x	Vcc	CPRES				Cx: "Smart Card Interface Block (SCIB)" : Standard ISO7816 port and "USB Host Controller" .	
	x	x	x	CVcc	CCLK					
	x	x	x		CRST					
	x	x	x		CIO					
	x	x	x		(2)	CC4, DP				Smart Card Interface: "DC/DC Converter" Supply Signals
	x	x	x		CC8, DM					
	x	x	x	CVcc	CVcc					
	x	x	x		CVSense					
	x	x	e ⁽¹⁾		CVss					
	x	x	x		LI					
	x	x	x		LO					

- Notes:
1. Should be connected to e-pad underneath QFN package
 2. According to the current configuration, these pins are supplied either by USB regulator or CVcc
 3. PORT C is not complete, due to RTC pins, dedicated to oscillator pads

3.1 Typical Application

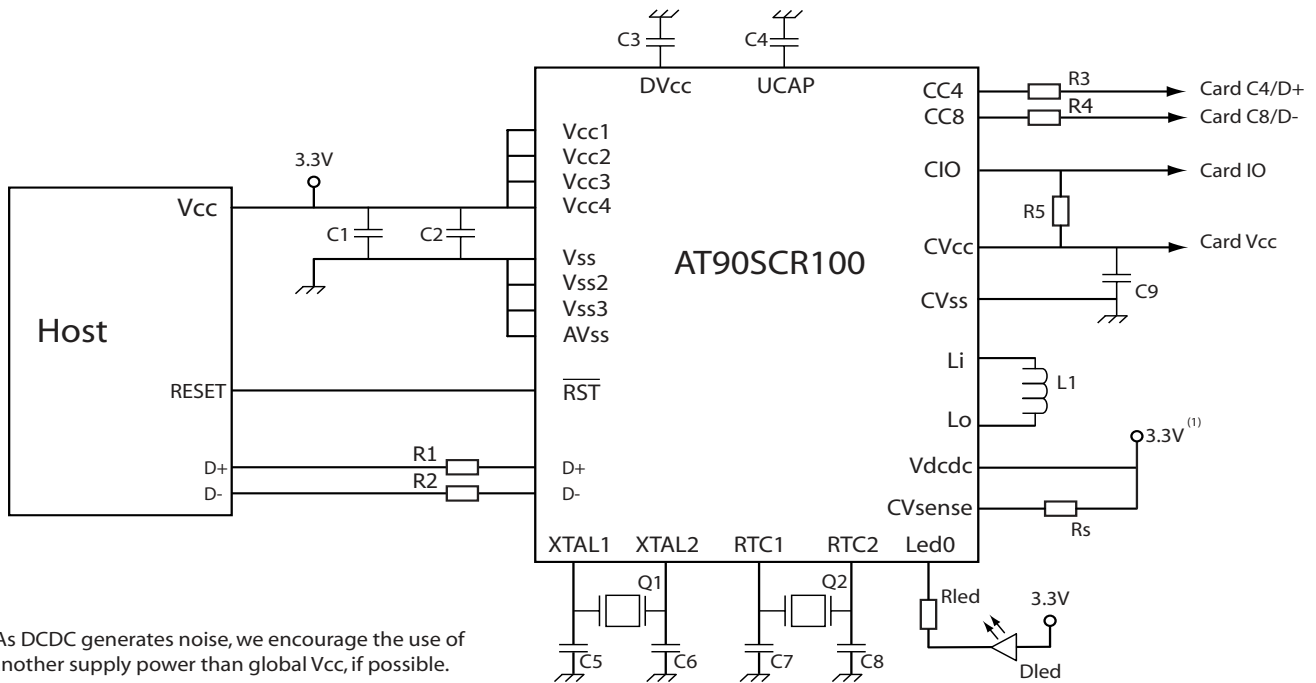

Table 3-2. External Components, Bill Of Materials

Reference	Description	Value	Comment
R1, R2 R3, R4	USB Pad Serial Resistor	22Ω +/-10%	-
R5	CIO Pull-up Resistor	10KΩ +/-10%	(Optional) Can be required for high speed communication
Rs	DCDC Sense Resistor	200mΩ +/-2% 125mW	Current Sensing: Overcurrent detection
C1	Power Supply Decoupling capacitor	4.7μF +/-10%	Maximum application capacitance allowed by USB standard is 10μF
C2	Power Supply Filter capacitor	100nF	-
C3	Internal Core Regulator Decoupling capacitor	2.2μF +/-10%	Used for internal regulator stability
C4	Internal USB Regulator Decoupling capacitor	2.2μF +/-10%	Used for internal regulator stability
C5, C6	PLL Filter capacitors	47pF +/-10%	-
C7, C8	RTC Filter capacitors	22pF +/-10%	Only if Real Time Counter is used.
C9	DCDC Decoupling Capacitor	10μF +/-10% esr=100mΩ	Tantalum capacitor is needed Recommended: AVX: TPSE106-035-200
L1	DCDC inductance	6.8μH esr=20.2mΩ	Recommended: Gowanda: SMP3316LP-681M
Q1	Crystal	8.0 Mhz	
Q2	Real Time Crystal	3.768 Mhz	Only if Real Time Counter is used
Rled/Dled	LED mechanism	--	Depends on the configuration of the Led Controller

3.1.1 Recommendations

1. In Order to reduce the board parasitics, the external components for DCDC converter should be as close as possible to the chip pins (ideally soldered directly on the pins).
2. In order to have a correct current limitation, the board parasitic resistances must be taken into account in the choice of the R_s value (e.g., if each metal line connecting R_s to the chip adds a $10\text{ m}\Omega$ resistance, the correct R_s value should be $200-2 \times 10 = 180\text{ m}\Omega$)
3. CV_{cc} and CV_{ss} lines must have very low resistance (short and wide metal line).
4. R_1 , R_2 , R_3 and R_4 must be placed as close as possible to the chip pins.
5. Connect e-pad to ground. If possible connect it to ground plane



Headquarters

Atmel Corporation
2325 Orchard Parkway
San Jose, CA 95131
USA
Tel: 1(408) 441-0311
Fax: 1(408) 487-2600

International

Atmel Asia
Unit 01-05 & 16, 19/F
BEA Tower, Millennium City 5
418 Kwun Tong Road
Kwun Tong, Kowloon
Hong Kong
Tel: (852) 2245-6100
Fax: (852) 2722-1369

Atmel Europe
Le Krebs
8, Rue Jean-Pierre Timbaud
BP 309
78054 Saint-Quentin-en-
Yvelines Cedex
France
Tel: (33) 1-30-60-70-00
Fax: (33) 1-30-60-71-11

Atmel Japan
9F, Tonetsu Shinkawa Bldg.
1-24-8 Shinkawa
Chuo-ku, Tokyo 104-0033
Japan
Tel: (81) 3-3523-3551
Fax: (81) 3-3523-7581

Product Contact

Web Site
www.atmel.com

Technical Support
scr@atmel.com

Sales Contact
www.atmel.com/contacts

Literature Requests
www.atmel.com/literature

Disclaimer: The information in this document is provided in connection with Atmel products. No license, express or implied, by estoppel or otherwise, to any intellectual property right is granted by this document or in connection with the sale of Atmel products. **EXCEPT AS SET FORTH IN ATMEL'S TERMS AND CONDITIONS OF SALE LOCATED ON ATMEL'S WEB SITE, ATMEL ASSUMES NO LIABILITY WHATSOEVER AND DISCLAIMS ANY EXPRESS, IMPLIED OR STATUTORY WARRANTY RELATING TO ITS PRODUCTS INCLUDING, BUT NOT LIMITED TO, THE IMPLIED WARRANTY OF MERCHANTABILITY, FITNESS FOR A PARTICULAR PURPOSE, OR NON-INFRINGEMENT. IN NO EVENT SHALL ATMEL BE LIABLE FOR ANY DIRECT, INDIRECT, CONSEQUENTIAL, PUNITIVE, SPECIAL OR INCIDENTAL DAMAGES (INCLUDING, WITHOUT LIMITATION, DAMAGES FOR LOSS OF PROFITS, BUSINESS INTERRUPTION, OR LOSS OF INFORMATION) ARISING OUT OF THE USE OR INABILITY TO USE THIS DOCUMENT, EVEN IF ATMEL HAS BEEN ADVISED OF THE POSSIBILITY OF SUCH DAMAGES.** Atmel makes no representations or warranties with respect to the accuracy or completeness of the contents of this document and reserves the right to make changes to specifications and product descriptions at any time without notice. Atmel does not make any commitment to update the information contained herein. Unless specifically provided otherwise, Atmel products are not suitable for, and shall not be used in, automotive applications. Atmel's products are not intended, authorized, or warranted for use as components in applications intended to support or sustain life.

© Atmel Corporation 2008. All Rights Reserved. Atmel®, Atmel logo and combinations thereof, AVR® and others are registered trademarks or trademarks of Atmel Corporation or its subsidiaries. Other terms and product names may be trademarks of others.