

THIS COPY IS PROVIDED ON A RESTRICTED BASIS AND IS NOT TO BE USED IN ANY WAY DETRIMENTAL TO THE INTERESTS OF PANDUIT CORP.

PANDUIT PART NUMBER	STUD SIZE	DIMENSIONS - in.					TOOLS
		A ± .03	W ± .01	C ± .02	M ± .03	H ± .01	
PV4-10R	#10	1.88 (47.75)	.55 (13.97)	.50 (12.7)	1.61 (40.89)	.20 (5.08)	CT-720 (CD-720PV8-2) CT-2600 (CD-2600-PV4)
PV4-14R	1/4"	1.88 (47.75)	.55 (13.97)	.50 (12.7)	1.61 (40.89)	.27 (6.86)	
PV4-56R	5/16"	1.95 (49.53)	.68 (17.27)	.50 (12.7)	1.61 (40.89)	.33 (8.38)	
PV4-38R	3/8"	1.95 (49.53)	.68 (17.27)	.50 (12.7)	1.61 (40.89)	.39 (9.91)	
PV4-12R	1/2"	2.04 (51.82)	.86 (21.84)	.50 (12.7)	1.61 (40.89)	.52 (13.21)	

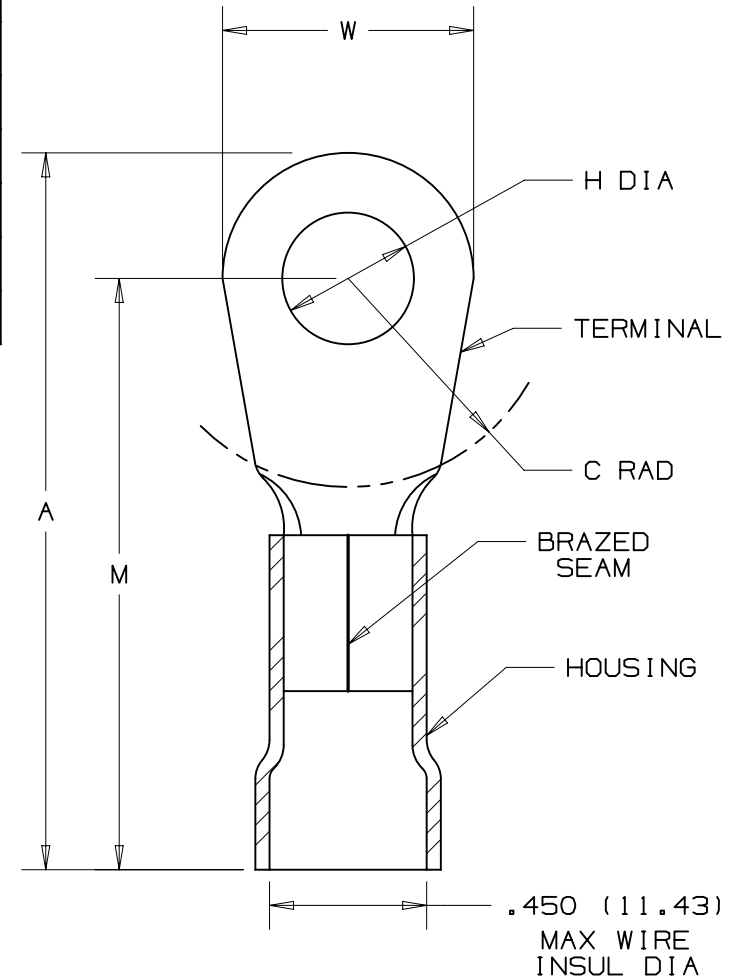

NOTES:

- cULus LISTED FOR:
 - A. 600V MAX VOLTAGE RATING
 - B. 221° F (105° C) MAX TEMP RATING
 - C. #4 AWG STRANDED COPPER WIRE
- SEE WWW.PANDUIT.COM FOR PACKAGE QUANTITIES
- MATERIAL:
 - A. STAMPING - .050" (1.27) THK, COPPER TIN PLATED
 - B. HOUSING - VINYL, YELLOW
- DIMENSIONS IN BRACKETS ARE IN MILLIMETERS
- WIRE STRIP LENGTH: $1/2 + 1/32$ (12.7 + .8) - 0



TITLE
#4 BARREL VINYL INSULATED RING TONGUE
.450 (11.43) MAX. WIRE INSUL. DIAMETER
CUSTOMER DRAWING

ITEM REVISION NAME N41217BB/06	PANDUIT
DATASET FILE NAME N41217BB/06 A41217	
UNLESS OTHERWISE SPECIFIED, DIMENSIONAL TOLERANCES ARE: IN [mm] .X ± .XXX ± .XX ± ANGLES ±	MATERIAL: SEE NOTE 3
THIRD ANGLE PROJECTION	DRAWING NUMBER: A41217
DRAWN BY DAW	DATE
CHK	SCALE NONE
DESCRIPTION	SHT 1 OF 1
ECN	SIZE A

D10100DA/16