

### Features

Frequency range : 1MHz to 200MHz  
 SMD seam sealing ceramic package  
 Supply voltage : 1.8V, 2.5V, 3.3V  
 CMOS output  
 Operating Temperature : -40°C~+105°C  
 Phase Jitter : 1ps(typ.)@100MHz, 3.3V  
 Dimensions : 5.0 x 3.2 x 1.2 mm  
 RoHS & REACH compliant, Pb-free, Halogen-free

### Applications

NB, PC, Tablet, Smartphone,  
 PC peripherals, IPC, Server, Storage,  
 Ethernet, USB...etc.  
 Audio ADC, Video,  
 AI Vision Processing Unit, CPLD,  
 FPGA, CPU, GPU, MCU, BMC...etc.

### Electrical Characteristics

Item	7CL	Conditions
Frequency Range (F <sub>0</sub> )	1MHz ~ 200MHz	V <sub>DD</sub> @ 2.5 or 3.3V
	1MHz ~ 125MHz	V <sub>DD</sub> @ 1.8V
Frequency Stability (F <sub>stab</sub> )	±25 ppm	-40°C ~ +85°C; Note [1]
	±50 ppm	-40°C ~ +105°C; Note [1]
Operating Temperature Range (T <sub>OTR</sub> )	-40°C ~ +85°C	
	-40°C ~ +105°C	
Supply Voltage (V <sub>DD</sub> )	1.8V, 2.5V, 3.3V	V <sub>DD</sub> ± 10%
Current Consumption (I <sub>DD</sub> )	30 mA Max.	
Standby current (I <sub>DD-ST</sub> )	5 mA Max.	OE = Low
Output Type / Load (C <sub>L</sub> )	CMOS / 15 pF	
Output Voltage High (V <sub>OH</sub> )	90% V <sub>DD</sub> Min.	V <sub>DD</sub> @ 2.5 or 3.3V
	(V <sub>DD</sub> - 0.4V) Min.	V <sub>DD</sub> @ 1.8V
Output Voltage Low (V <sub>OL</sub> )	10% V <sub>DD</sub> Max.	V <sub>DD</sub> @ 2.5 or 3.3V
	0.4V Max.	V <sub>DD</sub> @ 1.8V
Rise & Fall Time (T <sub>r</sub> / T <sub>f</sub> )	5 ns Max.	10% ~ 90% of V <sub>DD</sub> level
Duty Cycle	45% ~ 55%	
Start-up Time	10 ms Max.	To 90% of final amplitude
Enable Voltage High (VIH), Logic "1"	70% V <sub>DD</sub> Min.	Enable control @ Pin 1
Enable Voltage Low (VIL), Logic "0"	30% V <sub>DD</sub> Max.	
Aging (F <sub>aging</sub> )	±3 ppm Max.	First year at 25°C
RMS Phase Jitter (PJ) [2] Fout range : 10MHz~40MHz @ Integrated from 12kHz~5MHz	1.2 ps Typ.	V <sub>DD</sub> @ 3.3V
	1.5 ps Typ.	V <sub>DD</sub> @ 2.5V
	2.0 ps Typ.	V <sub>DD</sub> @ 1.8V
RMS Phase Jitter (PJ) [2] Fout range : 40MHz~200MHz @ Integrated from 12kHz~20MHz	1.0 ps Typ.	V <sub>DD</sub> @ 3.3V
	1.1 ps Typ.	V <sub>DD</sub> @ 2.5V
	1.5 ps Typ.	V <sub>DD</sub> @ 1.8V

#### Notes:

[1] Inclusive of frequency tolerance at 25°C, variation over temperature, supply voltage variation, aging and vibration.

[2] Phase Jitter will be slightly different according to output frequency and supply voltage.

**Testing diagram:**

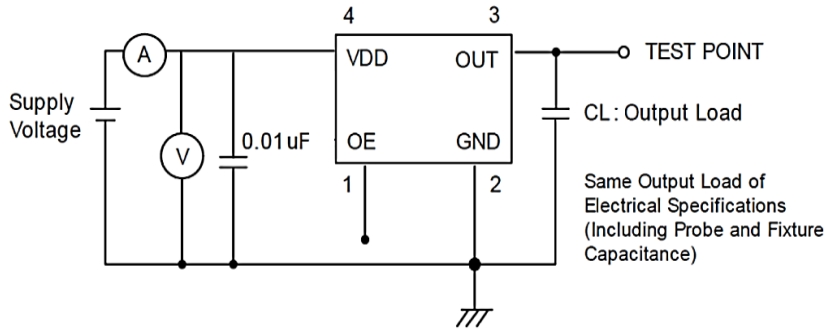

Pad 1 (OE)	Pad 3 (output)	Oscillator
High (or open)	OSC out	Normal operation
Low	High impedance	Stop oscillation

**Notes:** Sets CL to 15pF for simulation IC load. Customer does not need to layout it in reality circ

**Waveform conditions :**

Waveform measurement system should have a min. bandwidth of 5 times the frequency being testec

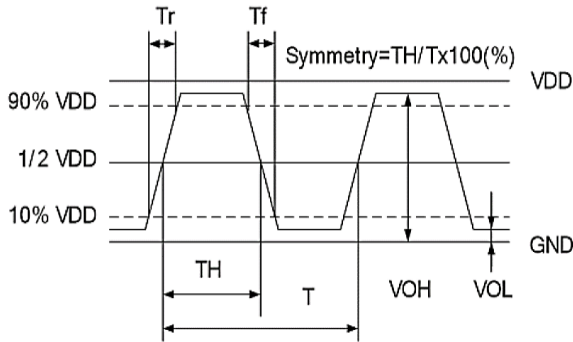

**Dimensions & Recommended Footprint**

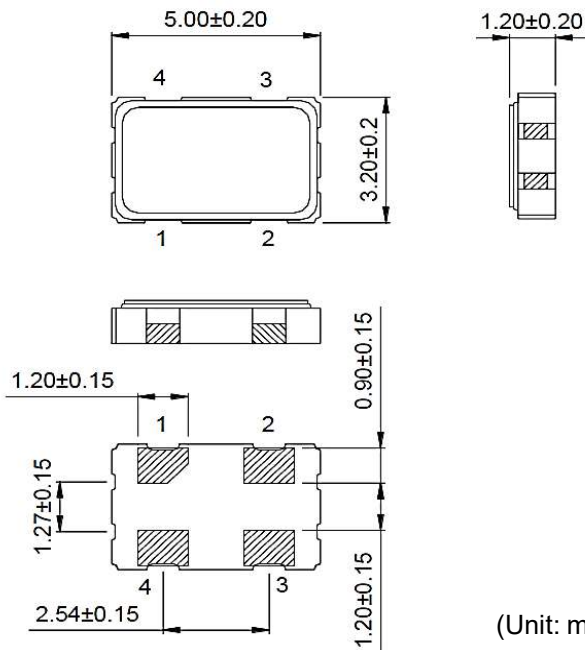

PAD FUNCTION:

- 1: OE
- 2: GND
- 3: OUT
- 4: VDD

(Unit: mm)

### Ordering Information

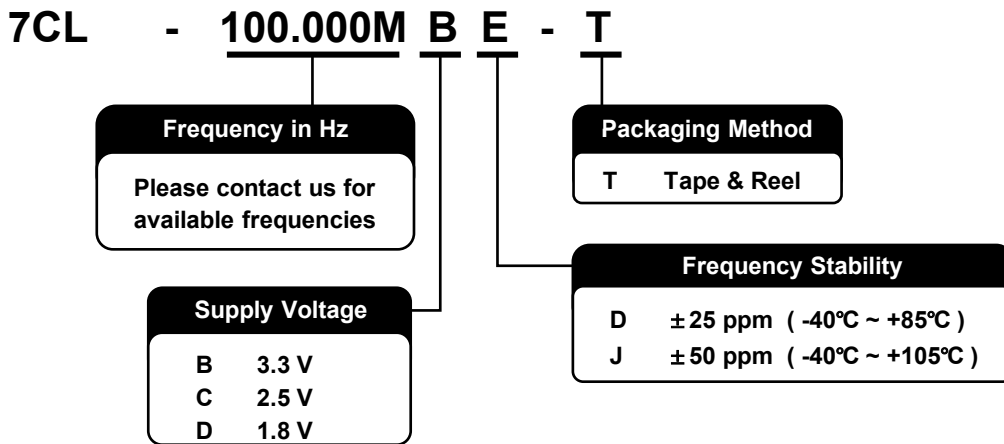

### Marking

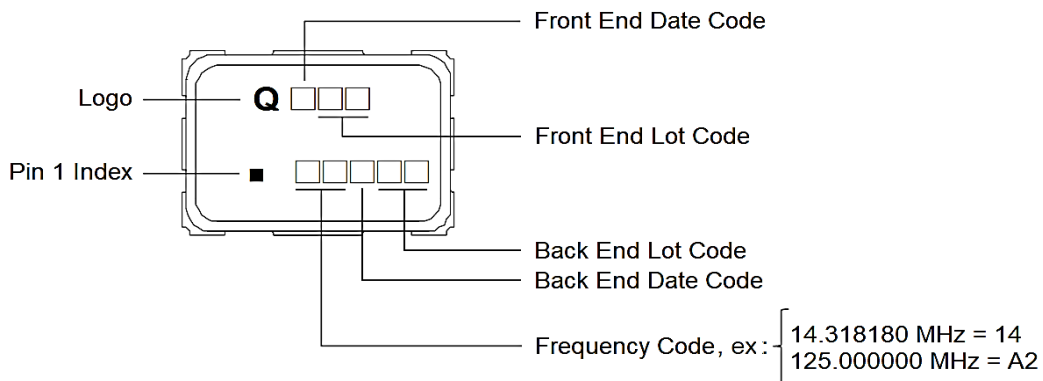

Date Code:

YEAR \ MONTH					JAN	FEB	MAR	APR	MAY	JUN	JUL	AUG	SEP	OCT	NOV	DEC
					A	B	C	D	E	F	G	H	J	K	L	M
2021	2025	2029	2033	2037	N	P	Q	R	S	T	U	V	W	X	Y	Z
2022	2026	2030	2034	2038	a	b	c	d	e	f	g	h	j	k	l	m
2023	2027	2031	2035	2039	n	p	q	r	s	t	u	v	w	x	y	z
2024	2028	2032	2036	2040												

\*This date code will be cycled every four years

### Packing

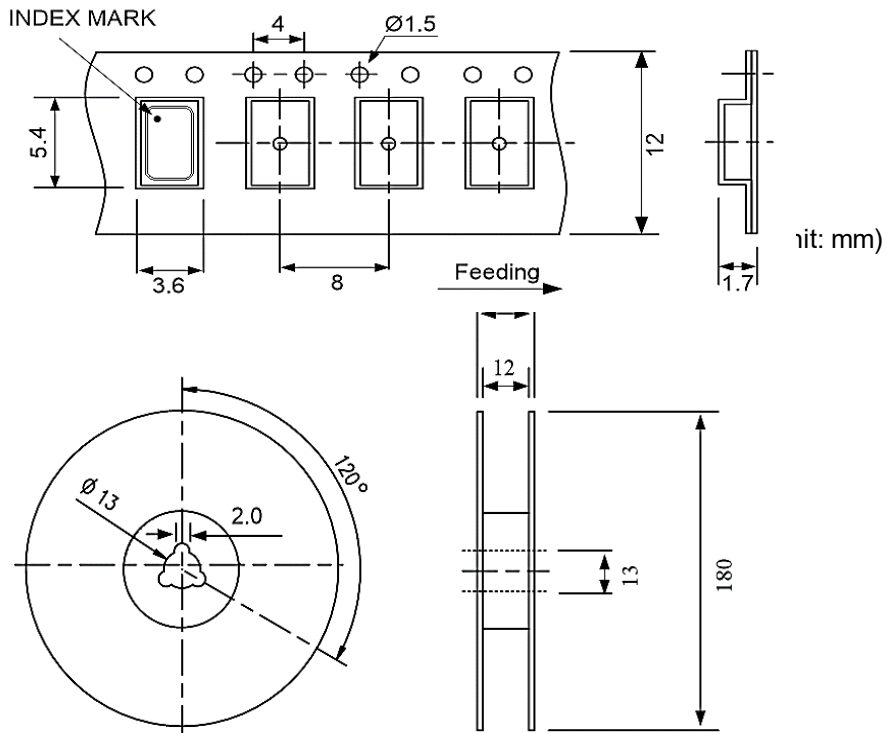

### Reflow Profile

Solder melting point : 220°C ± 10°C, 60 sec. Min.

Peak temperature : 260°C ± 10°C, 10 sec. Min.

