

5

4

3

2

1

SPECIFICATION

Mating Cycles	500
Filter type	C
Capacitance	3900pf±20%
Working Voltage	100v
Current Rating	7.5A
Insulation Resistance	>1GΩ

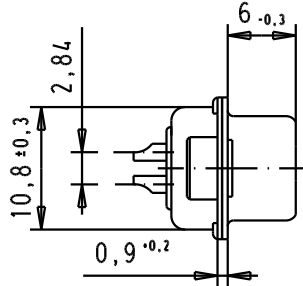
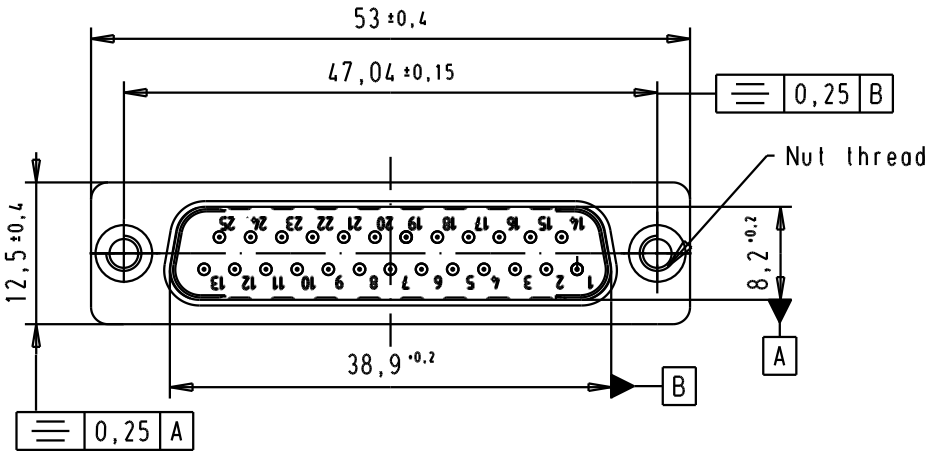

Solder bucket for AWG 20

FREQUENCY (MHz)	ATTENUATION (dB)
5	6dB
10	11dB
50	25dB
100	35dB
500	35dB
1000	32dB

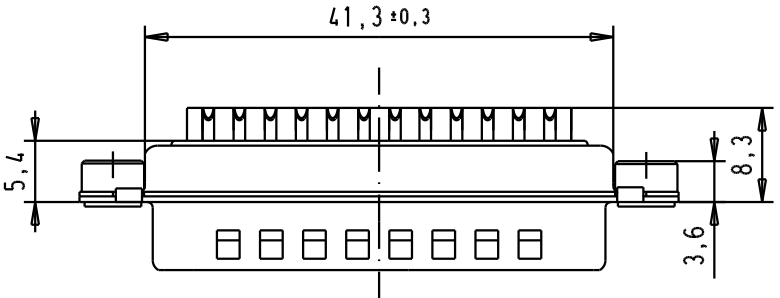



D

C

B

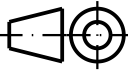
A

					Detail.	Dat.	Name	 All Dim. in mm Orig. Size DIN A 4	D-Sub, male, Straight 25 Poles, turned solder buckets, tin plated shell with dimples and clinch nuts	Mo?MsLab/ Scale 1.5:1		
					Insp.							
					Stand.							
09643217248	M3		33423	06/02/06	JMDR	HARTING EURL F-95972 Paris					TB 0964321724x	Blatt/ Page 1 / 1
09643217247	UNC 4-40		31058	8-JUL-02	CV							
Part number	Nut thread		Mod.	Dat.	Name							