



ANATECH ELECTRONICS INC
RF & Microwave Filters & Products

39000 MHz Cavity Band Pass Filter

Part Number: AE39000B11561



Electrical Specifications

Center Frequency: 39 GHz
Passband: 36-42 GHz
Passband Insertion Loss: $\leq 1.5\text{dB}$
Passband VSWR: $\leq 1.7:1$
Rejection: $\geq 45\text{dB}$ @ 31.5 GHz
Rejection2: $\geq 45\text{dB}$ @ 45 GHz
Impedance: 50 Ohms
Power: 5 Watts Max.

Mechanical

Mounting Method: Through Holes
Connector Type: 2.92mm (F)
Dimensions: 40 X 16 x 11 mm

Environmental

Operating Temperature: 15°C to +40°C
Storage Temperature: 5°C to +60°C
Shock: 20 G. 11ms
Vibration: 20 G. 5 to 200Hz

Outline Drawing:

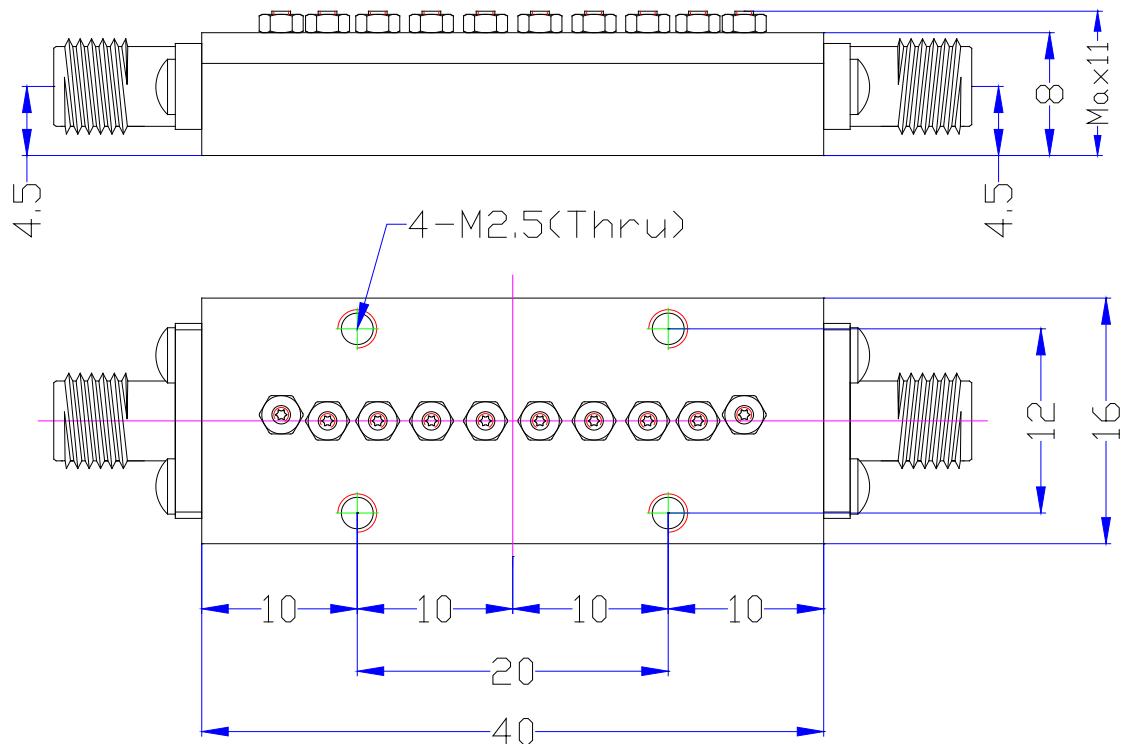



ANATECH ELECTRONICS INC
RF & Microwave Filters & Products

39000 MHz Cavity Band Pass Filter

Part Number: AE39000B11561



Response Plot:

