

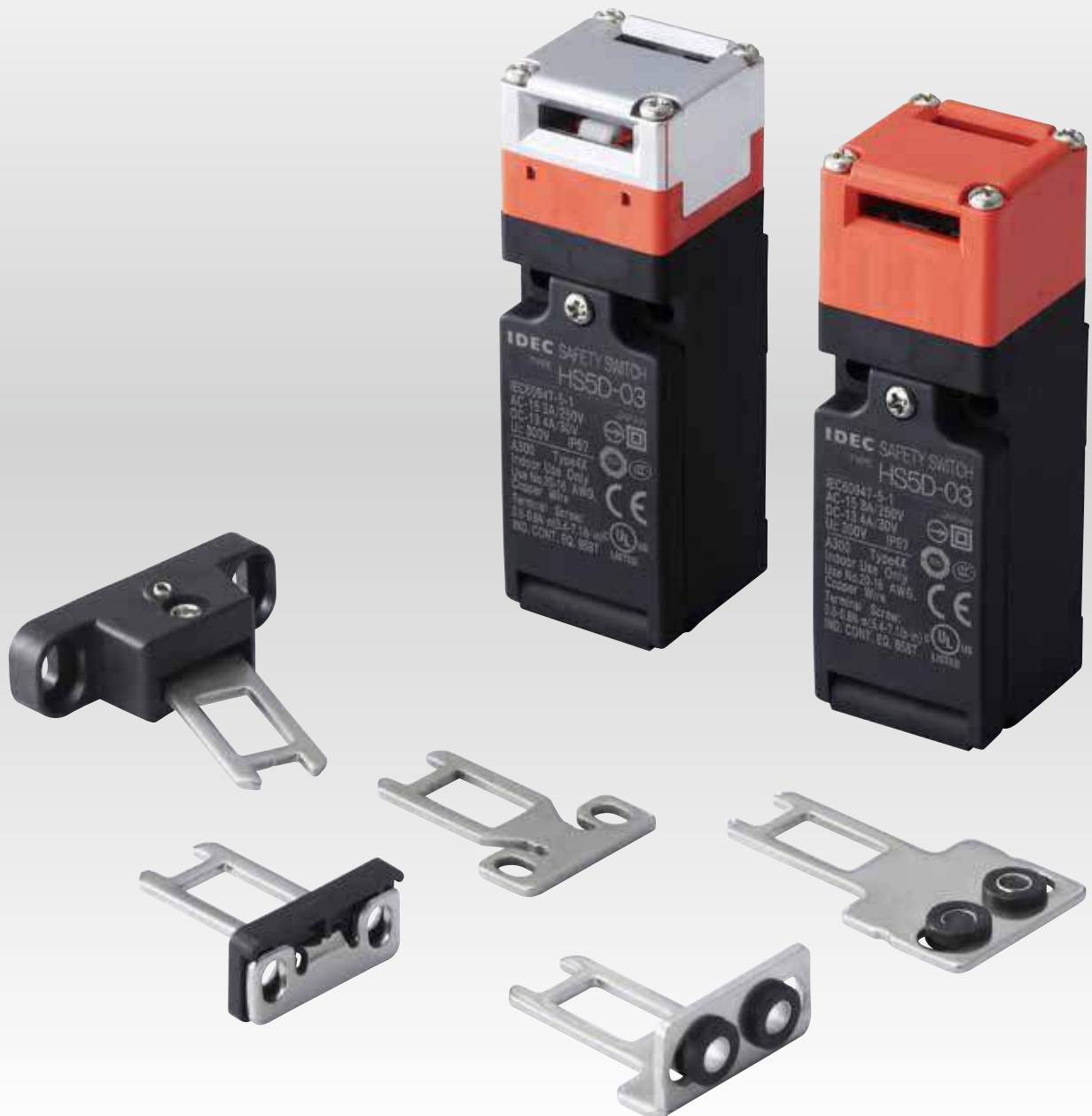

Think Automation and beyond...

## HS5D Miniature Interlock Switches

### Head Removal Detection Function for Safer Performance



IDEC CORPORATION

# New Generation Miniature Interlock Switches

IDEC's new unique "Head Removal Detection Function" is a new generation technology that assures safety and satisfies international safety standards.

## Head Removal Detection Function

All HS5D models are equipped with "Head Removal Detection Function." When the head is removed, such as when the head is rotated, the main circuit (11-12) turns OFF.

### HS5D-12 (example)

When the actuator is removed or inserted, the operation of the main circuits (11-12, 21-22) are the same. However, when the head is removed, disparity is detected (11-12: OFF, 21-22: ON). The disparity of the contacts detects the removal of the head.

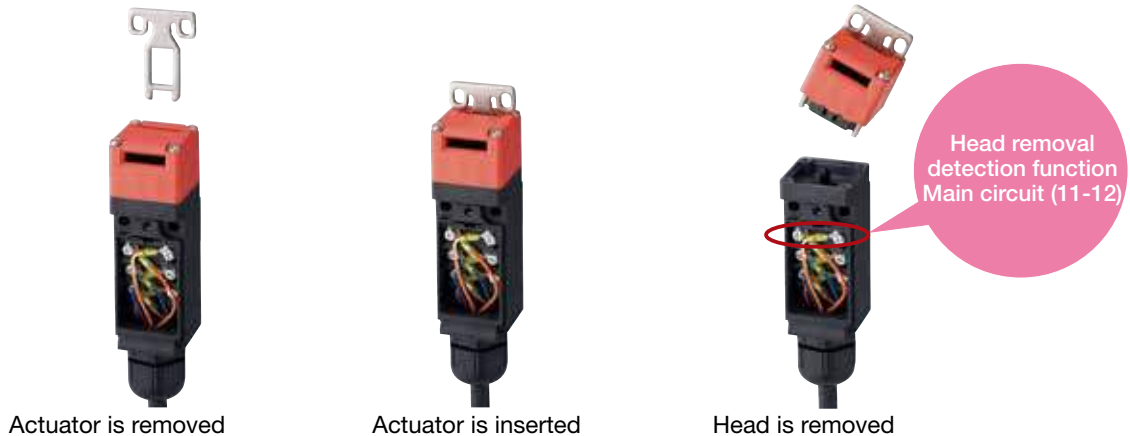

### HS5D-12

	When actuator is removed	When actuator is inserted	When head is removed
Main circuit (NC) ⊕ 11, 12	OFF	ON	OFF
Main circuit (NC) ⊕ 21, 22	OFF	ON	ON

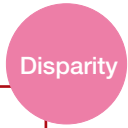

Note: Head removal detection function is not a direct opening action mechanism.

### Existing Interlock Switches

	When actuator is removed	When actuator is inserted	When head is removed
Main circuit (NC) ⊕ 3, 4	OFF	ON	ON
Monitor circuit (NC) ⊕ 1, 2	OFF	ON	ON

## Small size with 3 contacts

- 3 contact types with dual enabling contacts and a monitor contact are available.
- Compact size. Can be installed in narrow spaces.
- M3 terminal screws make wiring easy.
- Gold-plated contact suitable for small loads.



## Actuators interchangeable with HS5E/HS5L

Actuators can be selected to suit door shapes and applications.

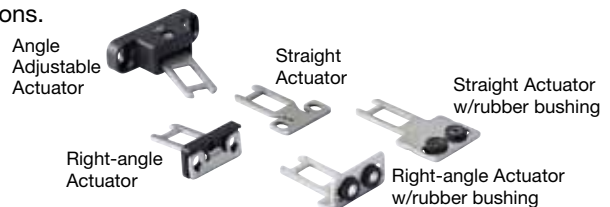

## Various Safety Product Accessories

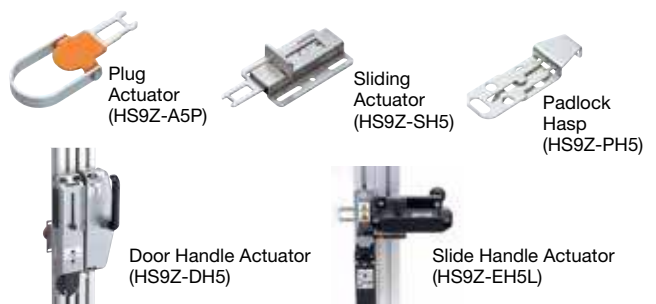

# HS5D Miniature Interlock Switches

## Head removal detection for safer performance.

- Head removal detection function turns OFF the main circuit (11-12) when the head of the HS5D is removed.
- 3 contact types with dual enabling contacts and a monitor contact are available. Can be installed in narrow spaces. (30W × 30D × 91H mm)
- The actuator is interchangeable with HS5E and HS5L.
- Double insulation structure eliminates the need for grounding.
- The head orientation can be rotated, allowing 8 different actuator entries.
- Degree of protection (contacts): IP67 (IEC60529)
- NC contacts with direct opening action (IEC/EN60947-5-1)
- Proprietary actuators prevent invalidation of the contacts (ISO14119).
- M3 terminal screws for easy wiring.
- Gold-plated contacts suitable for small loads.



Note: Contact IDEC for KOSHA approved model.



## Specifications

Applicable Standards	EN ISO14119 IEC60947-5-1 EN60947-5-1 (TÜV approval) GS-ET-15 (TÜV approval) UL508 (UL listed) CSA C22.2 No. 14 (c-UL listed) GB14048.5 (CCC approval) IEC60204-1/EN60204-1 (applicable standards for use)
Type and Coded Level	Type 2 low level coded interlocking device (ISO 14119)
Operating Temperature	-30 to +70°C (no freezing)
Relative Humidity	45 to 85% (no condensation)
Storage Temperature	-40 to +80°C (no freezing)
Pollution Degree	3
Impulse Withstand Voltage	4 kV
Contact Resistance	50 mΩ maximum (initial value)
Insulation Resistance (500V DC megger)	Between live and dead metal parts: 100 MΩ minimum Between terminals of different poles: 100 MΩ minimum
Electric Shock Protection Class	Class II (IEC61140)
Degree of Protection	IP67 (IEC60529)
Shock Resistance	Damage limits: 1000 m/s <sup>2</sup>
Vibration Resistance	Operating extremes: 10 to 55 Hz, amplitude 0.5 mm Damage limits: 30 Hz, amplitude 1.5 mm
Actuator Operating Speed	0.05 to 1.0 m/s
Direct Opening Travel	10 mm minimum
Direct Opening Force	50N minimum
Operating Frequency	900 operations per hour
Mechanical Durability	1,000,000 operations minimum (GS-ET-15)
Electrical Durability	100,000 operations minimum (AC-12 250V, 6A) 1,000,000 operations minimum (24V AC/DC, 100 mA) (operation frequency: 900 operations per hour)
Performance of Terminals 11-12 of Removed Head Unit	Mechanical damage limits: 10 operations min. Insulation resistance: 100 MΩ (initial value) Dielectric strength: 1000V, 1 minute (initial value)
Conditional Short-circuit Current	100A (250V) (note)
Weight (approx.)	Plastic head: 80g, Metal head: 110g

Note: Use a 250V/10A fast-blow fuse as a short-circuit protector.

## Contact Ratings

Rated Insulation Voltage (Ui)		300V			
Thermal Current (Ith)		10A			
Rated Voltage (Ue)		30V	125V	250V	
Rated Current (Ie) *	AC	Resistive load (AC-12)	10A	10A	6A
		Inductive Load (AC-15)	10A	5A	3A
	DC	Resistive load (DC-12)	8A	2.2A	1.1A
		Inductive Load (DC-13)	4A	1.1A	0.6A

- Minimum applicable load (reference): 5V AC/DC, 1 mA  
(Applicable range may vary with operating conditions and load types.)
- \*TÜV rating: AC-15 3A/250V, DC-13 4A/30V

## Part No. Development

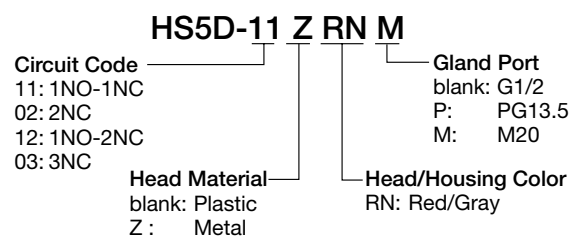

## Parts Description

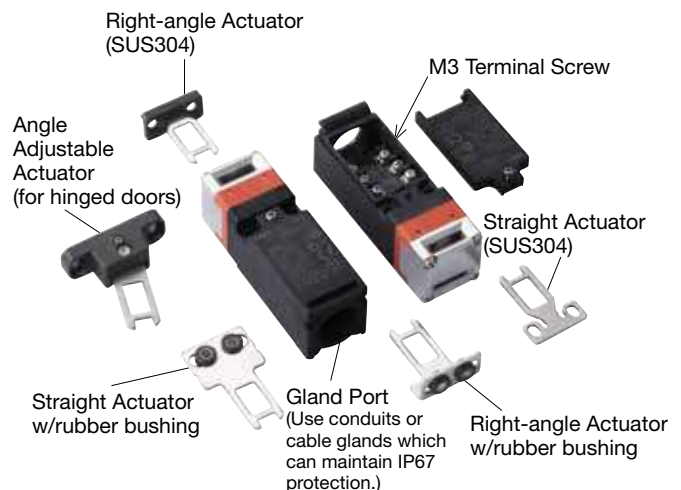

# HS5D Miniature Interlock Switches

## Miniature Safety Interlock Switch

Package Quantity: 1

Contact Configuration	Gland Port Size	Part No.	
		Plastic Head	Metal Head
<b>1NC-1NO</b> Main Circuit ⊖ 11-12 Monitor Circuit ⊖ 23-24 	G1/2	<b>HS5D-11RN</b>	<b>HS5D-11ZRN</b>
	PG13.5	<b>HS5D-11RNP</b>	<b>HS5D-11ZRNP</b>
	M20	<b>HS5D-11RNM</b>	<b>HS5D-11ZRNM</b>
<b>2NC</b> Main Circuit ⊖ 11-12 Monitor Circuit ⊖ 21-22 	G1/2	<b>HS5D-02RN</b>	<b>HS5D-02ZRN</b>
	PG13.5	<b>HS5D-02RNP</b>	<b>HS5D-02ZRNP</b>
	M20	<b>HS5D-02RNM</b>	<b>HS5D-02ZRNM</b>
<b>2NC-1NO</b> Main Circuit ⊖ 11-12 Main Circuit ⊖ 21-22 Monitor Circuit ⊖ 33-34 	G1/2	<b>HS5D-12RN</b>	<b>HS5D-12ZRN</b>
	PG13.5	<b>HS5D-12RNP</b>	<b>HS5D-12ZRNP</b>
	M20	<b>HS5D-12RNM</b>	<b>HS5D-12ZRNM</b>
<b>3NC</b> Main Circuit ⊖ 11-12 Main Circuit ⊖ 21-22 Monitor Circuit ⊖ 31-32 	G1/2	<b>HS5D-03RN</b>	<b>HS5D-03ZRN</b>
	PG13.5	<b>HS5D-03RNP</b>	<b>HS5D-03ZRNP</b>
	M20	<b>HS5D-03RNM</b>	<b>HS5D-03ZRNM</b>

## Actuator

Package Quantity: 1

Name	Part No.
Straight	<b>HS9Z-A51</b>
Straight w/rubber bushings	<b>HS9Z-A51A</b>
Right-angle	<b>HS9Z-A52</b>
Right-angle w/rubber bushings	<b>HS9Z-A52A</b>
Angle Adjustable (vertical/horizontal) Type	<b>HS9Z-A55</b>

## Accessories

Package Quantity: 1

Name	Part No.	Remarks
Plug Actuator	<b>HS9Z-A5P</b>	Can also be used for HS5E and HS5L.
Door Handle Actuator	Handle Unit	<b>HS9Z-DH5RH</b> Can also be used for HS5E and HS5L. For right-hand door.
		<b>HS9Z-DH5LH</b> Can also be used for HS5E and HS5L. For left-hand door.
	Switch Cover Unit	<b>HS9Z-DH5C</b> Used for installing the interlock switch inside. Can also be used for HS5E.
	HS5D Installation Kit	<b>HS9Z-DH5B</b> Used for mounting HS5D.
Sliding Actuator	<b>HS9Z-SH5</b>	Can also be used for HS5E and HS5L.
Slide Handle Actuator	<b>HS9Z-EH5L</b>	Can also be used for HS5E and HS5L.
Padlock Hasp	<b>HS9Z-PH5</b>	Can also be used for HS5E and HS5L.

## Contact Configuration and Operation Chart

Model	Contact Configuration	Contact Operation Chart (reference)
HS5D-11*	Main Circuit: ⊖ 11-12 Monitor Circuit: ⊖ 23-24 	
HS5D-02*	Main Circuit: ⊖ 11-12 Monitor Circuit: ⊖ 21-22 	
HS5D-12*	Main Circuit: ⊖ 11-12 Main Circuit: ⊖ 21-22 Monitor Circuit: ⊖ 33-34 	
HS5D-03*	Main Circuit: ⊖ 11-12 Main Circuit: ⊖ 21-22 Monitor Circuit: ⊖ 31-32 	

## Terminal Arrangement

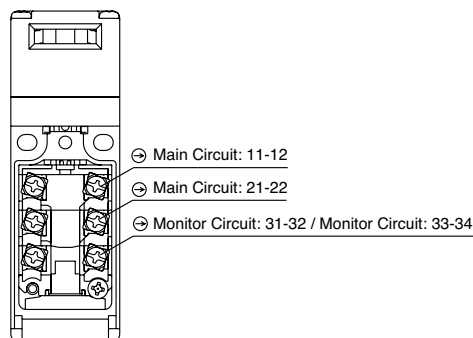

- The operation characteristics shown in the chart above are for the HS9Z-A51. For other actuator types, add 1.3 mm.
- The operation characteristics show the contact status when the actuator enters the entry slot of an interlock switch.

# HS5D Miniature Interlock Switches

## Dimensions and Mounting Hole Layouts

HS5D-□□ZRN□ (Metal Head)  
With HS9Z-A51 Straight Actuator

RP: Reference mounting position

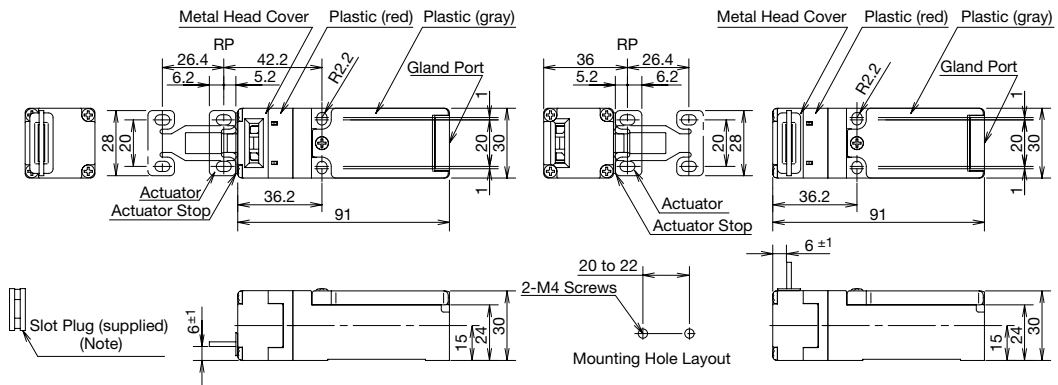

With HS9Z-A52 Right-angle Actuator

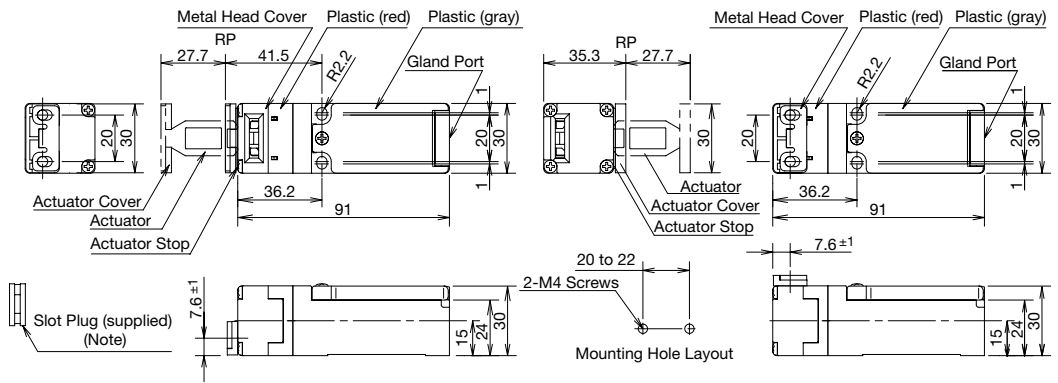

All dimensions in mm.

HS5D-□□RN□ (Plastic Head)  
With HS9Z-A51 Straight Actuator

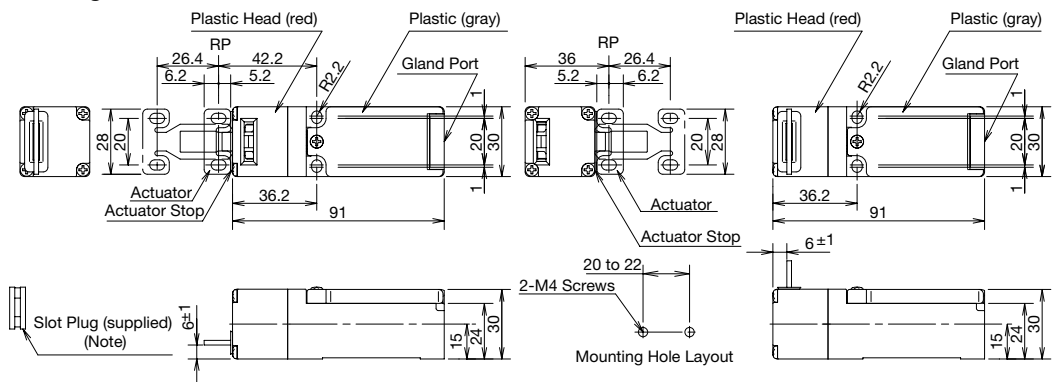

With HS9Z-A52 Right-angle Actuator

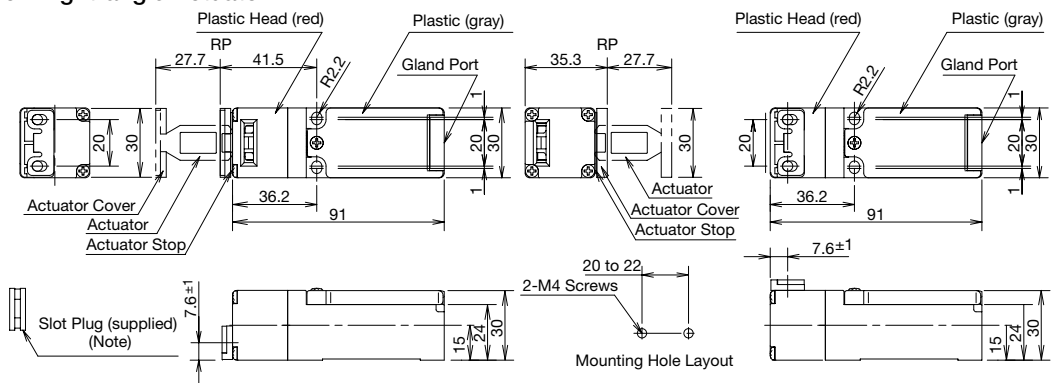

Note: Plug the unused actuator insertion slot using the slot plug supplied with the interlock switch.

All dimensions in mm.

# HS5D Miniature Interlock Switches

## Actuator Dimensions

### Straight (HS9Z-A51)

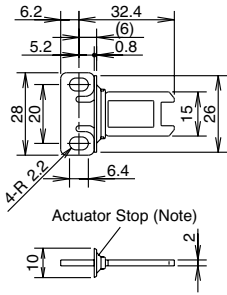

### Right-angle (HS9Z-A52)

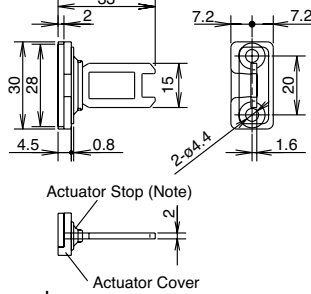

### Straight w/rubber bushing (HS9Z-A51A)

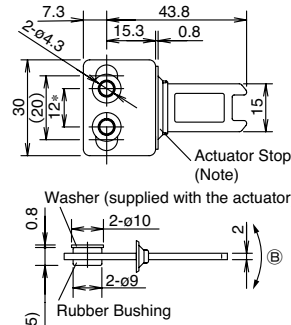

### Right-angle w/rubber bushing (HS9Z-A52A)

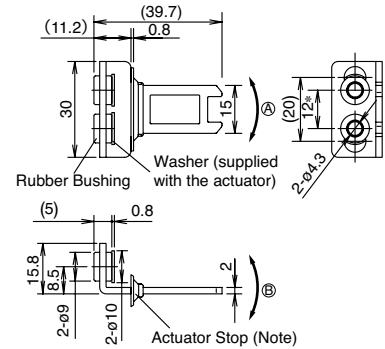

### Actuator Mounting Hole Layout (Straight, Right-angle)

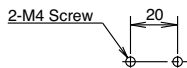

### Angle Adjustable (HS9Z-A55)

#### Horizontal Swing

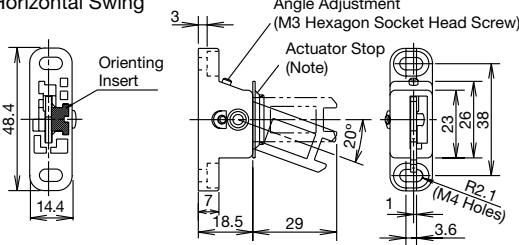

#### Vertical Swing

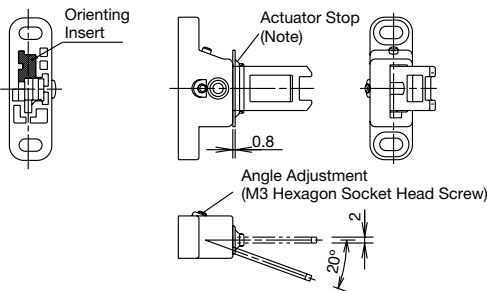

### Actuator Mounting Hole Layout (horizontal/vertical swing)

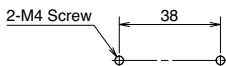

Note: The actuator stop is supplied with the actuator and used when adjusting the actuator position. Remove the actuator stop after the actuator position is determined.

\* The mounting center distance is set to 12 mm at factory. When 20-mm distance is required, adjust the distance by moving the rubber bushings.

Ⓐ Ⓑ: The actuator has flexibility to the directions indicated by the arrows. When 20-mm distance is selected, the actuator swings vertically.

### Actuator Mounting Hole Layout (Straight w/rubber bushing) (Right-angle w/rubber bushing)

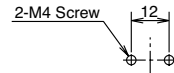

\* Mounting centers can be widened to 20 mm by moving the rubber cushions.

### Actuator Mounting Reference Position

As shown in the figure below, the mounting reference position of the actuator when inserted in the interlock switch is where the actuator stop placed on the actuator lightly touches the interlock switch.

Note: After mounting the actuator, remove the actuator stop from the actuator.

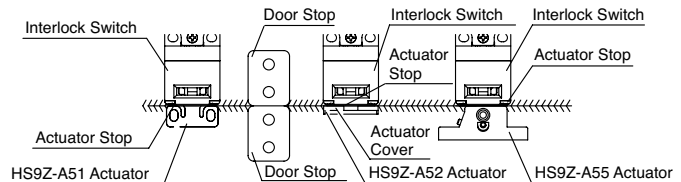

### Actuator Orientation (Angle Adjustable)

The angle of actuator swing can be changed using the orienting insert (made of plastic) installed on the back of the actuator. Do not lose the orienting insert, otherwise the actuator will not operate properly.

## ⚠ Safety Precautions

- In order to avoid electric shock or fire, only the professional engineer authorized by the operator must be allowed turn the power off before installation, removal, wire connection, maintenance, or inspection of the interlock switch.
- If relays are used in the circuit between the interlock switch and the load, use only safety relays, since welded or sticking contacts of standard relays may invalidate the functions of the interlock switch (performing risk assessment and making up a safety circuit which satisfies the requirements of the safety category).
- For wiring, use wires of a proper size to meet the voltage and current requirements. Tighten the terminal screws to a recommended torque of 0.6 to 0.8 N·m. Improper soldering or failure to tighten the terminal screw may cause overheating and fire.
- Do not install the actuator in the location where a human body may come in contact. Otherwise injury may occur.
- Do not place a PLC in the circuit between the interlock switch and the load. Safety security can be endangered in the event of a malfunction of the PLC.
- Do not disassemble or modify the interlock switch, otherwise a malfunction or an accident may occur.

- HS5D interlock switches are Type 2 low level coded interlocking devices (ISO14119). According to ISO14119, the following is required to minimize defeat when installing and constructing systems:

1. Prevent dismantling or de-positioning of the elements of the interlocking device by use of non-detachable fixing (e.g. welding, gluing, one-way screws, riveting). However, use of non-detachable fixing can be an inappropriate solution in cases where a failure of the interlocking device during lifetime of the machinery can be expected and a fast change is necessary. In this case measures mentioned below, should be used to provide the required level of risk reduction.
2. Apply at least one out of the four measures below.
  - ① Mounting out of reach.
  - ② Physical obstruction or shielding.
  - ③ Mounting in hidden position.
  - ④ Integration of defeat monitoring by means of status monitoring/cyclic testing.

## Operating Instructions

- Regardless of door types, do not use the interlock switch as a door stop. Install a mechanical door stop at the end of the door to protect the interlock switch against excessive force.
- Do not apply excessive shock to the interlock switch when opening or closing the door. A shock to the interlock switch exceeding 1,000 m/s<sup>2</sup> may cause damage to the interlock switch.
- Do not open the lid of the interlock switch. Loosening the screws may cause damage to the interlock switch.
- Prevent foreign objects such as dust and liquids from entering the interlock switch while connecting a conduit or wiring.
- Plug the unused actuator entry slot using the slot plug supplied with the interlock switch.
- Use proprietary actuators only. When other actuators are used, the interlock switch may be damaged.
- Safety function of the door interlock switch will be lost if a spare key is inserted into the interlock switch. Make sure that a spare key is not used on the interlock switch.
- Do not cut the actuator. Modification of the actuator may cause damage.
- Although the HS9Z-A51A/A52A actuators alleviate shock when the actuator enters a slot in the interlock switch, make sure that excessive shock is not applied. If the rubber bushings become deformed or cracked, replace with new ones.

## Mounting Examples

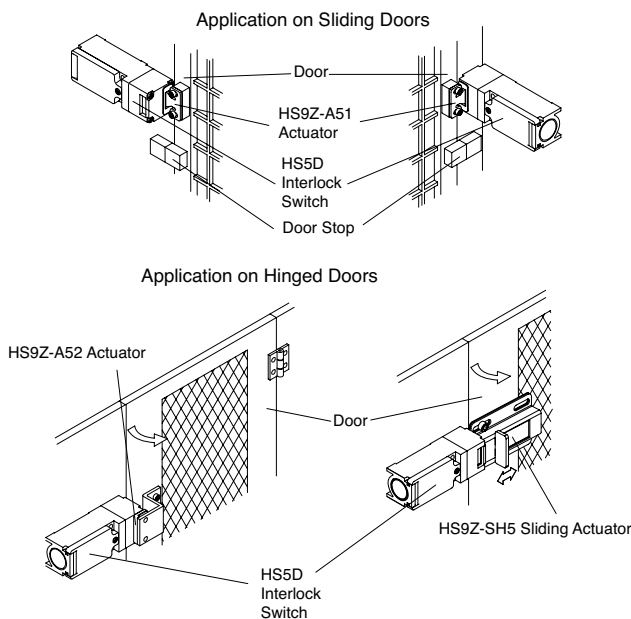

## Installing the Head

Do not use the metal head of the HS5E/HS5L interlock switch on the HS5D.

When using these HS5D and HS5E/HS5L interlock switches adjacently, ensure that the heads are not interchanged.

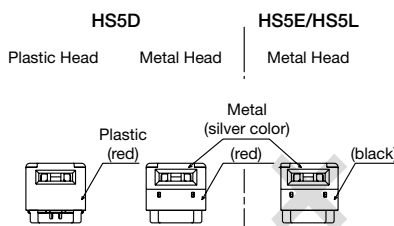

## Minimum Radius of Hinged Door

- When using the interlock switch for a hinged door, refer to the minimum radius of doors shown below. For the doors with small minimum radius, use angle adjustable actuators (HS9Z-A55).

Note: Because deviation or dislocation of hinged door may occur in actual applications, make sure of the correct operation before installation.

### When using the HS9Z-A52 Actuator

- When the door hinge is on the extension line of the interlock switch surface:

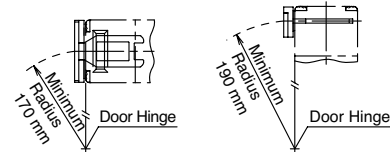

- When the door hinge is on the extension line of the actuator mounting surface:

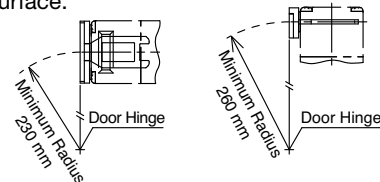

### When using the HS9Z-A55 Angle Adjustable Actuator

- When the door hinge is on the extension line of the interlock switch surface: 50mm

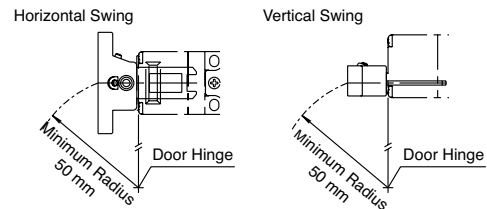

- When the door hinge is on the extension line of the actuator mounting surface: 70mm

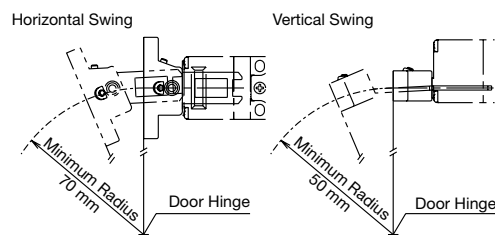

### Actuator Angle Adjustment for the HS9Z-A55

- Using the angle adjustment screw, the actuator angle can be adjusted (see figures on page 6). Adjustable angle: 0 to 20°
- The larger the adjusted angle of the actuator, the smaller the applicable radius of the door opening. After installing the actuator, open the door. Then adjust the actuator so that its edge can be inserted properly into the actuator entry slot of the interlock switch.
- After adjusting the actuator angle, apply Loctite to the adjustment screw so that the screw will not loosen.

# HS5D Miniature Interlock Switches

## Operating Instructions

### Rotating the Head

- The head of the HS5D can be rotated by removing the four screws from the corners of the HS5D head and reinstalling the head in the desired orientation. When reinstalling the head, make sure that no foreign object enters the interlock switch. Tighten the screws tightly, because loose tightening may cause malfunction.
- Recommended screw tightening torque: 0.6 to 1.1 N·m

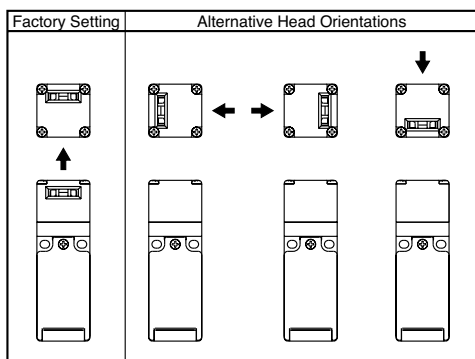

### Head Removal Detection Function

Only the NC contact of the main circuit (11-12) turns OFF (open) when the head is removed, such as when rotating the head. Because NC contacts of other than the main circuit (11-12) turn ON (closed), be sure to connect the main circuit (11-12) to the safety circuit.

### Recommended Tightening Torque

- Interlock Switch Mounting Screw:  $1.8 \pm 2.2$  N·m (two M4 screws)
- Housing Lid Screw: 0.2 to 0.4 N·m (M3 screw)
- Terminal Screw: 0.6 to 0.8 N·m (M3 screw)
- Connector: 2.7 to 3.3 N·m
- Actuators
  - HS9Z-A51:  $1.8 \pm 2.2$  N·m (two M4 screws)
  - HS9Z-A52:  $0.8 \pm 1.2$  N·m (two M4 Phillips screws)
  - HS9Z-A51A/A52A: 1.0 to 1.5 N·m (two M4 screws)
  - HS9Z-A55: 1.0 to 1.5 N·m (two M4 screws)
- If the above recommended tightening torque values are not satisfied, check loosening after installation thoroughly.
- Mounting bolts must be provided by the user.
- To avoid unauthorized or unintended removal of the interlock switch and the actuator, it is recommended that the interlock switch and the actuator be installed in an unremovable manner, for example using special screws or welding the screws.

### Applicable Crimping Terminal

When using crimping terminals, be sure to install insulation tubes on the crimping terminals to prevent electric shocks. When using stranded wires, make sure that loose wires do not cause short circuit. Also do not solder the terminal to prevent loose wires.

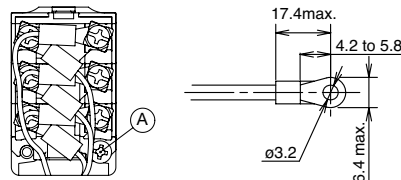

Recommended manufacturer: JST

Part No.: N0.5-3

Applicable wire size (with insulation tube): 0.2 to 0.5 mm<sup>2</sup>

Note: Do not remove screw A during wiring. Removing the screw may cause malfunction or damage.

### Applicable Wire Size

0.5 to 1.5 mm<sup>2</sup>

### Applicable Cable Glands

Use a cable gland with a degree of protection IP67.

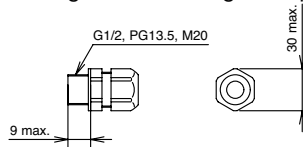

### When Using Flexible Conduits (Example)

- Flexible conduit example: VF-03 (made by Nihon Flex)

Gland Port Size	Plastic Cable Gland	Metal Cable Gland
G1/2	—	RLC-103 (Nihon Flex)
PG13.5	—	RBC-103PG13.5 (Nihon Flex)
M20	—	RLC-103EC20 (Nihon Flex)

### When Using Multi-core Cables (Example)

Gland Port Size	Plastic Cable Gland	Metal Cable Gland
G1/2	SCS-10* (Seiwa Electric)	ALS-16** (Nihon Flex)
PG13.5	ST13.5 (LAPP)	ABS-**PG13.5 (Nihon Flex)
M20	ST-M20X1.5 (LAPP)	ALS-**EC20 (Nihon Flex)

- Different cable glands are used depending on the cable sheath diameter. When purchasing a cable gland, confirm that the cable gland is applicable to the cable sheath diameter.
- When using a 1/2-14NPT cable gland, use the HS5D interlock switch with M20 gland port (Part No.: HS5D-\*\*\*M) together with an adaptor (Part No.: MA-M/NPT 20X1.5 5402-0110, LAPP) and a gasket (Part No.: GP M20, LAPP). Install a gasket between the interlock switch and the adaptor. Apply sealing tape between the cable gland and the adaptor to make sure of IP67 protection for the enclosure.

# IDEC CORPORATION

## Head Office

6-64, Nishi-Miyahara-2-Chome, Yodogawa-ku, Osaka 532-0004, Japan

<b>USA</b>	IDEC Corporation	Tel: +1-408-747-0550	opencontact@idec.com
<b>Germany</b>	IDEC Electrotechnik GmbH	Tel: +49-40-25 30 54 - 0	service@eu.idec.com
<b>Singapore</b>	IDEC Izumi Asia Pte. Ltd.	Tel: +65-6746-1155	info@sg.idec.com
<b>Thailand</b>	IDEC Asia (Thailand) Co., Ltd	Tel: +66-2-392-9765	sales@th.idec.com
<b>Australia</b>	IDEC Australia Pty. Ltd.	Tel: +61-3-8523-5900	sales@au.idec.com
<b>Taiwan</b>	IDEC Taiwan Corporation	Tel: +886-2-2698-3929	service@tw.idec.com

<b>Hong Kong</b>	IDEC Izumi (H.K.) Co., Ltd.	Tel: +852-2803-8989	info@hk.idec.com
<b>China/Shanghai</b>	IDEC (Shanghai) Corporation	Tel: +86-21-6135-1515	idec@cn.idec.com
<b>China/Shenzhen</b>	IDEC (Shenzhen) Corporation	Tel: +86-755-8356-2977	idec@cn.idec.com
<b>China/Beijing</b>	IDEC (Beijing) Corporation	Tel: +86-10-6581-6131	idec@cn.idec.com
<b>Japan</b>	IDEC Corporation	Tel: +81-6-6398-2527	marketing@idec.co.jp

 [www.idec.com](http://www.idec.com)

Specifications and other descriptions in this brochure are subject to change without notice.  
2017 IDEC Corporation, All Rights Reserved.

EP1579-2 APRIL 2017

