

MARCHIO AMP, CODICE AMP DI NAZIONALITA'
 AMP TRADEMARK, MANUFACTURING LOCATION CODE.

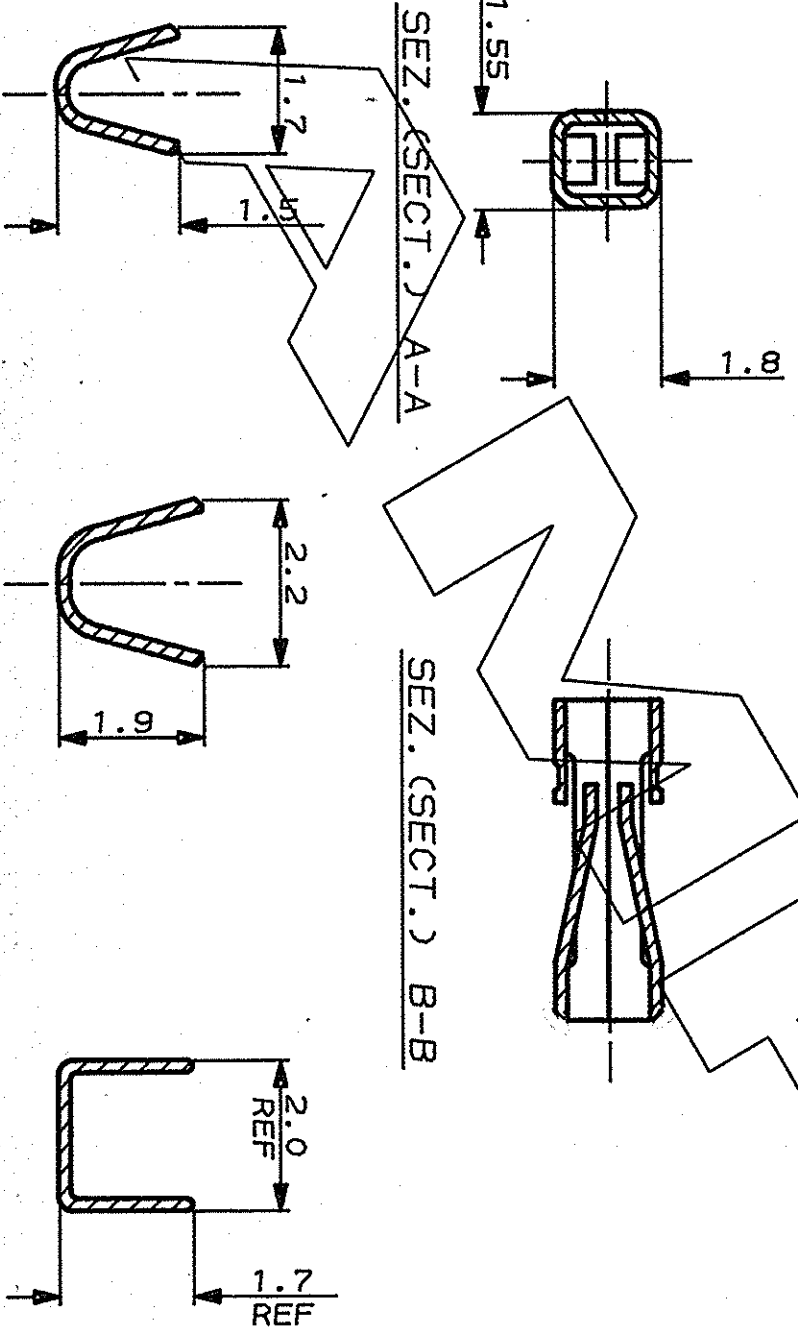
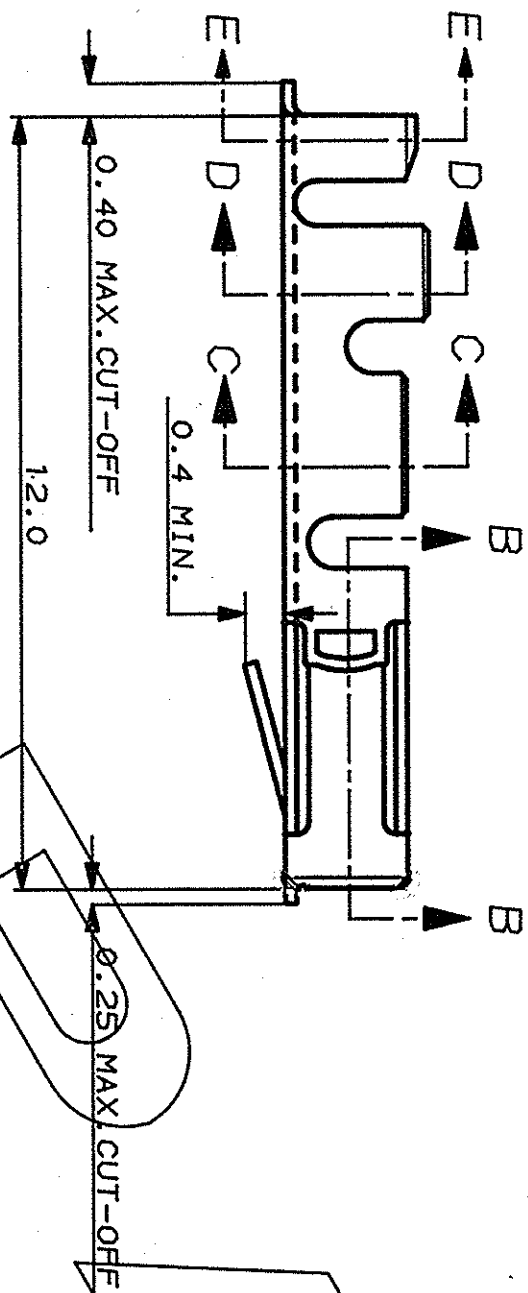

NOTE (NOTES)

1. MATERIALE (MATL.): BRONZO FOSFOROSO (PHOSPHOR BRONZED).
2. FINITURA (FINISH): STAGNATO 0.8µM ECCETTO LE ZONE TRANCIAATE. (TIN PLATED 0.8µM ALL OVER EXCEPT FOR CUTTING EDGES).
3. PER MINI-APPLICATORE (FOR MINI-APPLICATOR) P/N 781119-2.
4. PER APPLICATORE STD. (FOR STD. APPLICATOR).
5. PER UTENSILE A MANO (FOR HANDTOOL) P/N 784044-1.

NOTE (NOTES)

1 & 2	1822206-2	280708-1	280708-2
MATERIALE E FINITURA, MATL. & FINISH	LOOSE-PIECE PART NUMBER:	STRIP PART NUMBER:	STRIP PART NUMBER:
	NOTA NOTED 5	GR. TO L. 2, NOTA NOTED 4	GR. TO R. 3, NOTA NOTED 3

CUSTOMER DWG. SOLO PER CLIENTE
FOR REFERENCE ONLY SOLO PER RIFERIMENTO

THIS DRAWING IS UNPUBLISHED
 © COPYRIGHT 1989 BY AMP INCORPORATED, HARRISBURG, PA. ALL INTERNATIONAL RIGHTS RESERVED. AMP PRODUCTS MAY BE COVERED BY U.S. AND FOREIGN PATENT AND/OR PATENT PENDING TOLERANZE SE NON DIVERSAMENTE SPECIFICATE
 DIM. ISOLANTE
 DIM. DIA. RANGE
 1.0-1.55 MM
 DIM. FILLO
 RANGE AND
 0.13-0.32 MM
 (25-22 AWG)
 SCALE

AMP
 AMP ITALIA S.p.A.
 Corso F.lli Cervelli, 15
 COLLENO (TORINO)

DESCRIZIONE
 AMPMODU II REC. CONTACT,
 HIGH PRESSURE, C.O.S. I.

REV.	REVISIONI	DIS. DATA	APP. DATA	LOC. SIZE	NUMERO	REV.	FOGLIO
B	AGGIORNATO E RIPRODOTTO	9. C. 17/89	9. C. 17/89	I	1	5	1
C	AGGIORNATO (REVISED)	9. C. 17/89	9. C. 17/89	A3C	280708	5	1
D	AGGIORNATO (REVISED)	9. C. 17/89	9. C. 17/89				
E	AGGIORNATO (REVISED)	9. C. 17/89	9. C. 17/89				
S	FATTO SU ORDINE ADD. E O. ESTERNE AGGIUNTI MARCHIO (TRADEMARK ADDED)	9. C. 17/89	9. C. 17/89				