

EVALUATION KIT
AVAILABLE**MAXIM**

Complete Backup Management IC for NiMH Batteries

MAX8672

General Description

The MAX8672 complete power manager for backup batteries in smart devices offers feature-programmable battery charging and main-system backup. The device includes a charger for 1- or 2-cell NiMH backup batteries. A low-quiescent current synchronous-rectified boost converter and LDO supply up to 20mA during system backup. The BST output is internally set to regulate at 3.05V. The MAX8672 LDO is powered from the boost converter output and is adjustable from 1.5V to 3.05V.

The MAX8672 features programmable charge current, undervoltage lockout (UVLO), and maximum cell voltage. Charging is controlled by both a timer and thermistor monitor. Battery UVLO prevents excessive battery discharge and keeps inactive-battery drain current below 50nA. In addition, both LDO and boost converter outputs block reverse current so that diodes are not needed when connecting these outputs directly to system supplies. The MAX8672 requires that a valid system supply be present before system backup operation can occur.

The MAX8672 is available in a 14-pin, 3mm x 3mm TDFN package and is rated for -40°C to +85°C operation.

Applications

PDA, Palmtop, and Wireless Handhelds
Smart Cell Phones

Pin Configuration

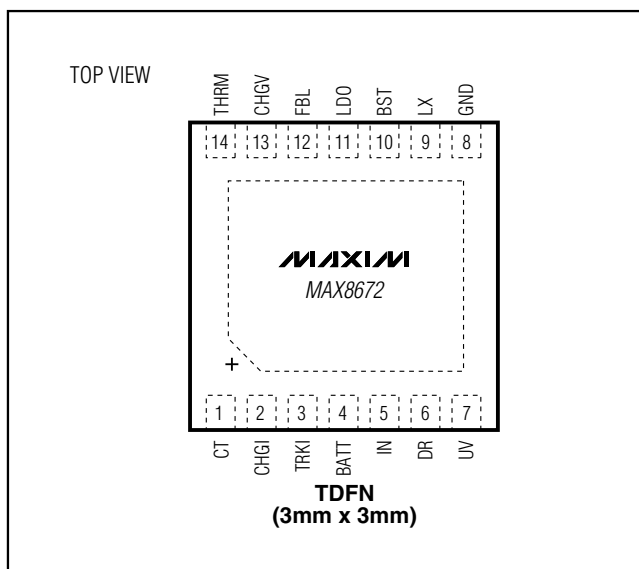

Features

- ◆ Charges 1- or 2-Cell NiMH Backup Batteries
- ◆ Programmable Charge Current
- ◆ DC Trickle Charge Mode for Maximum Cell Life
- ◆ Deep-Recovery Charge Restores Cells < 1V
- ◆ Programmable Charge Timer
- ◆ Programmable Charge-Voltage Limit and Battery UVLO
- ◆ Reverse Current Blocking on BATT, LDO, and Boost—No Diodes Needed
- ◆ No Battery Drain When Off (< 50nA)
- ◆ Thermistor Sensing Disables Standard Charge
- ◆ Battery Restart Charge Threshold Prevents Overcharge

Ordering Information

PART	PIN-PACKAGE	PKG CODE
MAX8672ETD+T	14 TDFN-14 (3mm x 3mm)	T14334+2

The MAX8672 operates in the -40°C to +85°C extended operating temperature range.

+Denotes lead-free package.

Typical Operating Circuit

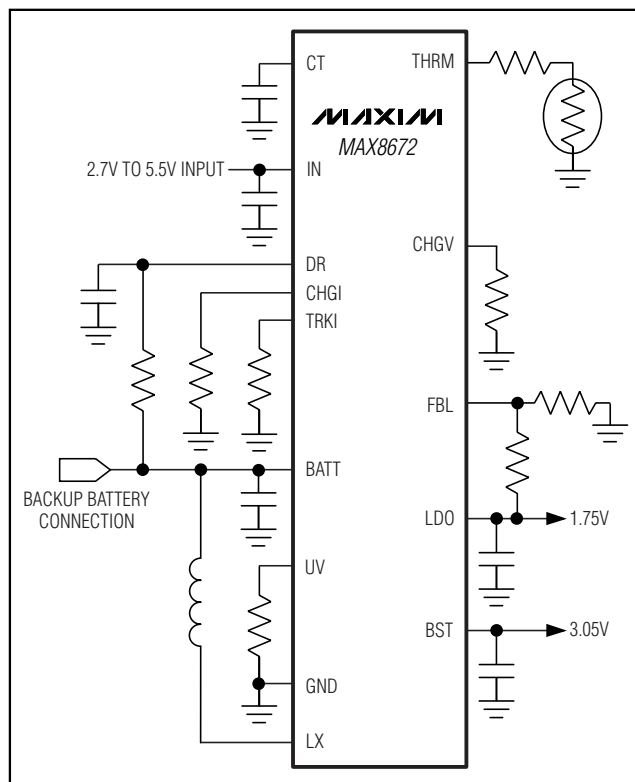
**MAXIM**

Maxim Integrated Products 1

For pricing, delivery, and ordering information, please contact Maxim/Dallas Direct! at 1-888-629-4642, or visit Maxim's website at www.maxim-ic.com.

Complete Backup Management IC for NiMH Batteries

ABSOLUTE MAXIMUM RATINGS

IN, BATT, BST, LDO, UV to GND	-0.3V to +6.0V
FBL to GND	-0.3V to (V _{BST} + 0.3V)
CT, CHGI, TRKI, CHGV, THRM, DR to GND	-0.3V to (V _{IN} + 0.3V)
ILX	0.9A _{RMS}

Continuous Power Dissipation (T _A = +70°C) 14-Pin, 3mm x 3mm TDFN (derate 18.2 mW/°C above +70°C)	1454.5mW
Operating Temperature Range	-40°C to +85°C
Junction Temperature	+150°C
Storage Temperature Range	-65°C to +150°C
Lead Temperature (soldering, 10s)	+300°C

Stresses beyond those listed under "Absolute Maximum Ratings" may cause permanent damage to the device. These are stress ratings only, and functional operation of the device at these or any other conditions beyond those indicated in the operational sections of the specifications is not implied. Exposure to absolute maximum rating conditions for extended periods may affect device reliability.

ELECTRICAL CHARACTERISTICS

(V_{IN} = 3.6V, T_A = -40°C to +85°C, C_{CT} = 0.1μF, unless otherwise noted.) (Note 1)

PARAMETER	CONDITIONS		MIN	TYP	MAX	UNITS
IN Voltage Range			2.7		5.5	V
IN Undervoltage Lockout Threshold	V _{IN} rising, hysteresis = 100mV (typ)		2.20	2.45	2.60	V
IN Supply Current	V _{BATT} > V _{BATT} (CHG)			40	100	μA
Internal Load Current on BST (Note 2)	V _{BST} = 3.3V, no BST or LDO load, boost and LDO on	V _{IN} = 3.3V		117	170	μA
		V _{IN} = 0V	T _A = -40°C to +50°C	91	125	
			T _A = -40°C to +85°C	91	150	
BATT Quiescent Supply Current—Backup Mode	V _{BATT} = 1.55V, V _{BST} = 3.3V, V _{IN} = 0V, V _{BATT} (CHG) = 1.5V			3		μA
BATT Quiescent Supply Current—Charging	V _{BATT} = 1.55V, V _{BST} = 3.3V, V _{IN} = 3.6V			3		μA
BATT Leakage Current to IN	V _{BATT} = 3.0V, V _{IN} = 0V	T _A = +25°C		0.01	0.1	μA
		T _A = +85°C		0.07		
Total BATT Battery Leakage Current During UVLO (BATT, LX, and DR Leakage)	V _{BATT} = 0 to 3.0V	T _A = -40°C to +50°C		5	50	nA
		T _A = +85°C		50		
CHARGER AND BATTERY						
CHGI Current-Limit Accuracy	1mA ≤ I _{BATT} (CHG) ≤ 20mA, V _{IN} - V _{BATT} > 400mV	T _A = -40°C to +85°C	-10		+10	%
		T _A = 0°C to +85°C	-10		+10	
			T _A = -40°C to +85°C	-15		
CHGI Bias Voltage				600		mV
CHGI Resistor Range			5		1000	kΩ
TRKI Current-Limit Accuracy	I _{BATT} (TRK) = 1mA	T _A = -40°C to +85°C	-10		+10	%
		T _A = 0°C to +85°C	-10		+10	
			T _A = -40°C to +85°C	-15		
DC Trickle-Current Programming Range	I _{BATT} (TRK)		0.1		1	mA
Charge-Current Programming Range	I _{BATT} (CHG)		0.1		20	mA
TRKI Bias Voltage				600		mV
TRKI Resistor Range			100		1000	kΩ
Charger Dropout Voltage	V _{IN} - V _{BATT} where I _{BATT} (CHG) falls by 10% of initial value; V _{IN} = 3.6V, I _{BATT} (CHG) = 20mA			250		mV

Complete Backup Management IC for NiMH Batteries

MAX8672

ELECTRICAL CHARACTERISTICS (continued)

($V_{IN} = 3.6V$, $T_A = -40^{\circ}C$ to $+85^{\circ}C$, $C_{CT} = 0.1\mu F$, unless otherwise noted.) (Note 1)

PARAMETER	CONDITIONS		MIN	TYP	MAX	UNITS
CHGV Output Current	$V_{CHGV} = 1V$			13		μA
CHGV Resistor Range			28.7		57.4	$k\Omega$
$V_{BATT(CHG)}$ Voltage-Limit Adjust Range	Measured at BATT		1.50		3.00	V
$V_{BATT(CHG)}$ Voltage-Limit Accuracy	$R_{CHGV} = 28.7k\Omega$	$T_A = +25^{\circ}C$	-1		+1	%
		$T_A = 0^{\circ}C$ to $+50^{\circ}C$	-1.25		+1.25	
		$T_A = -30^{\circ}C$ to $+85^{\circ}C$	-2.25		+2.25	
$V_{BATT(TRK)}$ to $V_{BATT(CHG)}$ Ratio	Sets 1.41V when $V_{CHGV} = 1.5V$, measured at BATT		0.926	0.940	0.954	—
$V_{BATT(RSTRT)}$ to $V_{BATT(CHG)}$ Ratio	Sets 1.225V when $V_{CHGV} = 1.5V$, measured at BATT		0.799	0.816	0.832	—
$V_{BATT(DR)}$ to $V_{BATT(CHG)}$ Ratio	Sets 1.00V when $V_{CHGV} = 1.5V$, measured at BATT; this is the V_{BATT} above which deep recovery (DR) turns off; the falling threshold is typically 50mV below this		0.653	0.667	0.680	—
V_{DR} Output Voltage to $V_{BATT(CHG)}$ Ratio	Measured at BATT; no load on DR		0.775	0.816	0.861	—
DR Load Regulation	$I_{DR} = 0$ to 10mA			10	20	%
Charge-Timer Accuracy	Does not include capacitor error	$T_A = +25^{\circ}C$			20	%
		$T_A = -40^{\circ}C$ to $+85^{\circ}C$			25	
Timer Adjust Range	CHG1 timer period, $C_{CT} = 0.047\mu F = 8h$ (480min)		2		2000	min
Thermistor Hot-Trip Point	$R_{THERM} = 100k\Omega$ at $T_A = +25^{\circ}C$, T_A rising		44	45	46	$^{\circ}C$
Thermistor Cold-Trip Point	$R_{THERM} = 100k\Omega$ at $T_A = +25^{\circ}C$, T_A falling		-2	-1	0	$^{\circ}C$
Thermistor Temperature Hysteresis				2		$^{\circ}C$
Hot-Trip Thermistor Resistance	T_A rising		42.00	43.71	45.42	$k\Omega$
	T_A falling			48.15		
Cold-Trip Thermistor Resistance	T_A falling		325.5	342.0	358.6	
	T_A rising			302.0		
UV Output Current	$V_{UV} = 1V$			4		μA
UV Resistor Range			49.9		215	$k\Omega$
UV Battery-Cutoff Programmable Range			0.8		3.5	V
UV Battery-Cutoff Accuracy	$R_{UV} = 49.9k\Omega$	$T_A = 0^{\circ}C$ to $+50^{\circ}C$	-2		+2	%
		$T_A = -30^{\circ}C$ to $+85^{\circ}C$	-3.25		+3.25	
LDO						
LDO Output-Voltage Range	Using external resistors, no load		1.5		3.05	V
FBL Regulation Voltage	$V_{BST} = 3.3V$, $V_{LDO} = 3.05V$		1.225	1.25	1.275	V
LDO Output Current	(Note 3)				20	mA
LDO Load Regulation	$V_{BST} = 3.3V$, $V_{LDO} = 3.05V$, $I_{LDO} = 1mA$ to 20mA			0.08	0.2	%/mA
LDO Dropout Voltage	$V_{LDO} = 2.5V$, $I_{LDO} = 10mA$			50	100	mV
LDO Dropout Resistance	$V_{LDO} = 2.5V$			5		Ω
FBL Input Bias Current	$V_{FBL} = 1.25V$	$T_A = +25^{\circ}C$		3	50	nA
		$T_A = +85^{\circ}C$		15		

Complete Backup Management IC for NiMH Batteries

ELECTRICAL CHARACTERISTICS (continued)

($V_{IN} = 3.6V$, $T_A = -40^{\circ}C$ to $+85^{\circ}C$, $C_{CT} = 0.1\mu F$, unless otherwise noted.) (Note 1)

PARAMETER	CONDITIONS	MIN	TYP	MAX	UNITS
BOOST CONVERTER					
BST Output Voltage		2.989	3.05	3.111	V
Boost Output Current	1-cell input (Note 3)			20	mA
LX Current Limit		400	500	600	mA
n-Channel On-Resistance	$I_{LX} = 200mA$		0.4	1	Ω
p-Channel On-Resistance	$I_{LX} = -200mA$		0.7	2	Ω
n-Channel Maximum On-Time		3.5	5	6.5	μs
p-Channel Off-Current Threshold		5	20	35	mA

Note 1: Parameters are 100% production tested at $T_A = +25^{\circ}C$. Limits over the operating temperature range are guaranteed by design.

Note 2: BATT current is higher due to boost ratio and efficiency.

Note 3: Total load from both BST and LDO cannot exceed 20mA.

Typical Operating Characteristics

($V_{IN} = 3.6V$, Circuit of Figure 6, $T_A = +25^{\circ}C$, unless otherwise noted.)

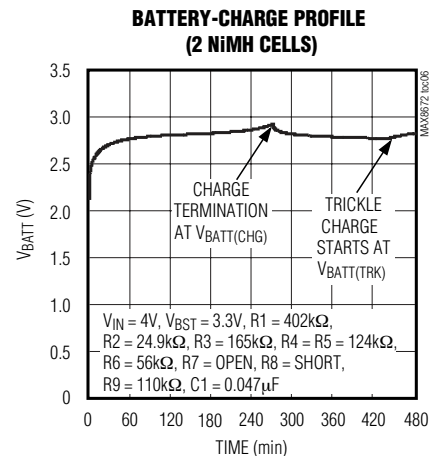
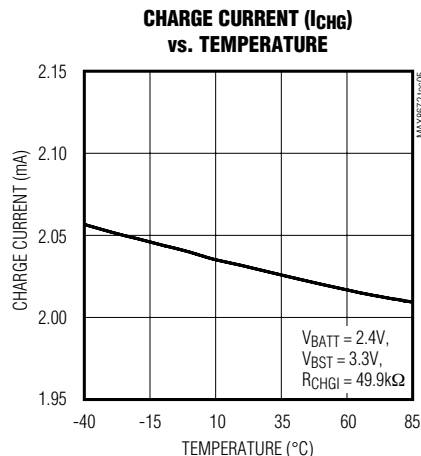
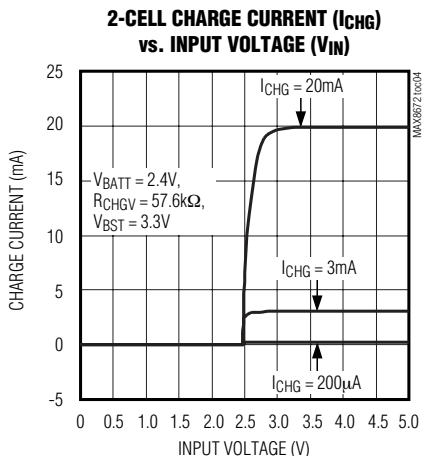
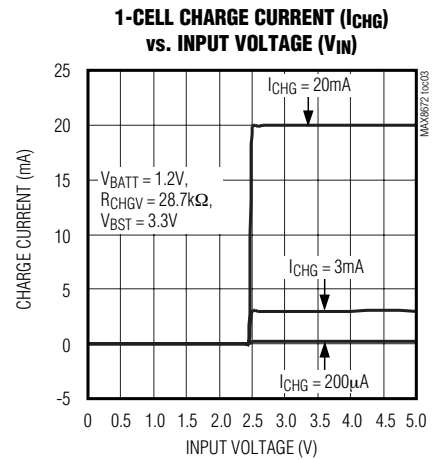
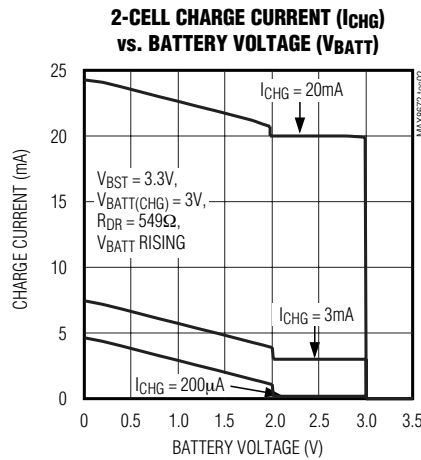
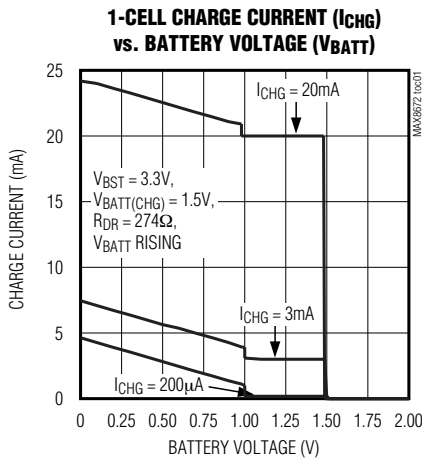

Complete Backup Management IC for NiMH Batteries

MAX8672

Typical Operating Characteristics (continued)

($V_{IN} = 3.6V$, Circuit of Figure 6, $T_A = +25^\circ C$, unless otherwise noted.)

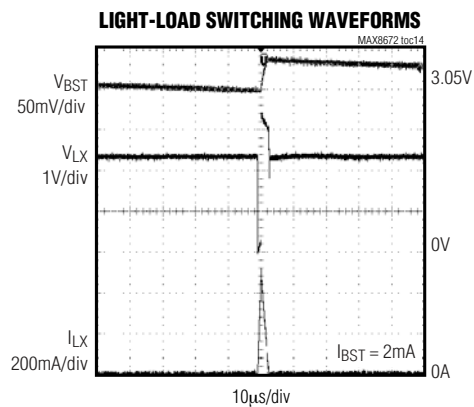
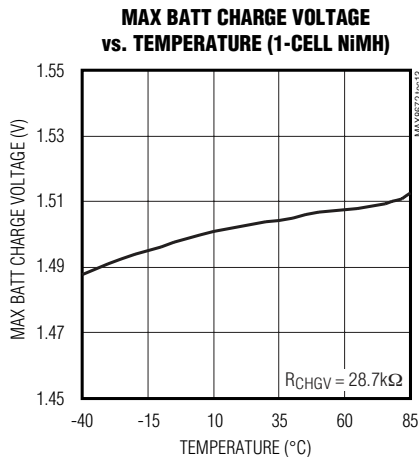
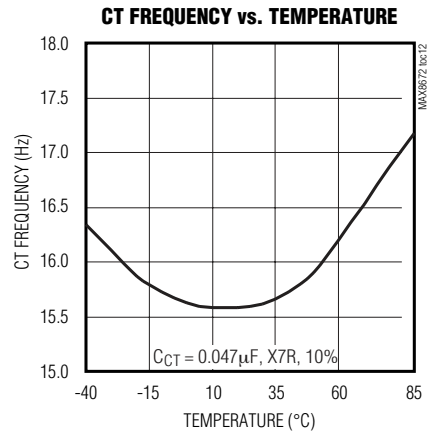
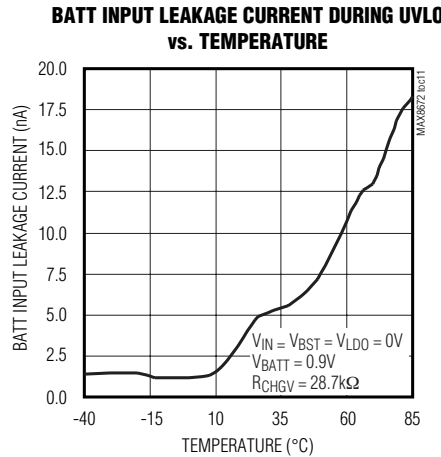
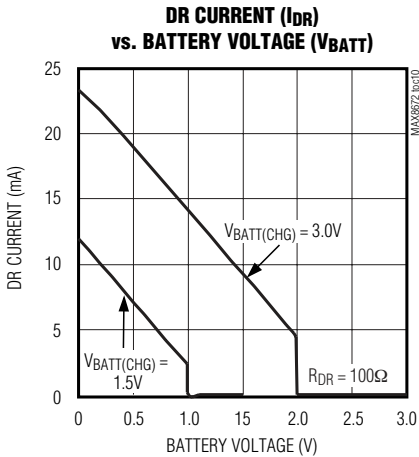
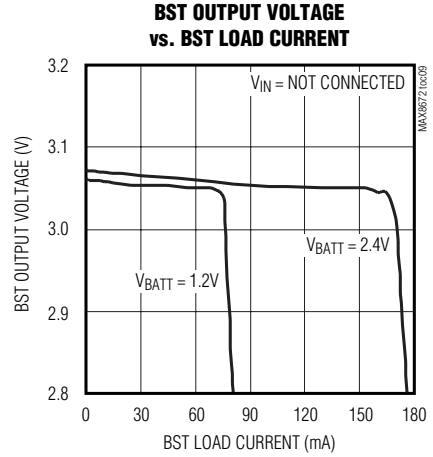
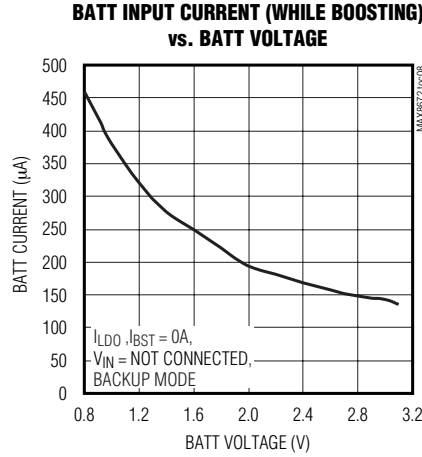
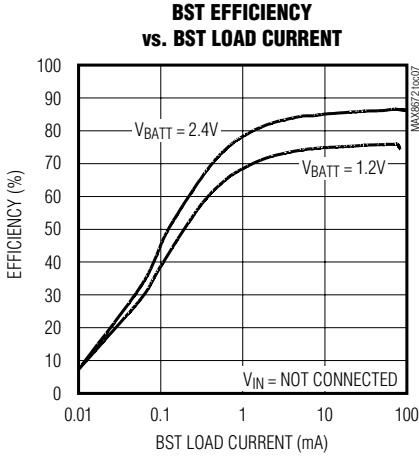

Complete Backup Management IC for NiMH Batteries

Typical Operating Characteristics (continued)

($V_{IN} = 3.6V$, Circuit of Figure 6, $T_A = +25^\circ C$, unless otherwise noted.)

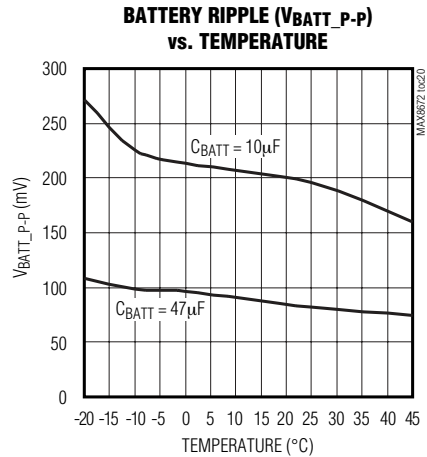
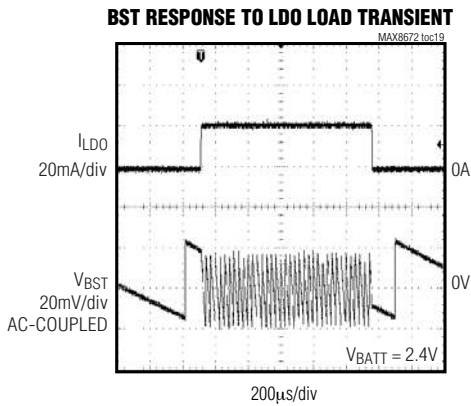
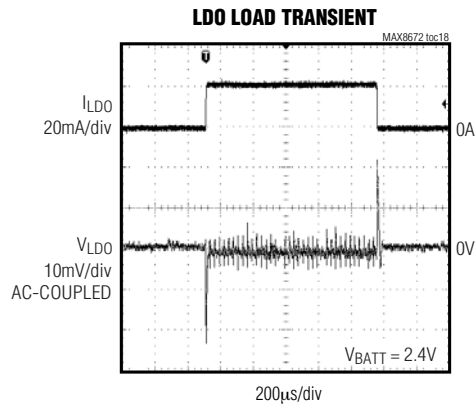
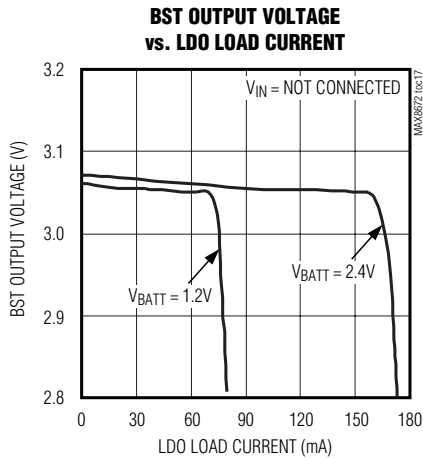
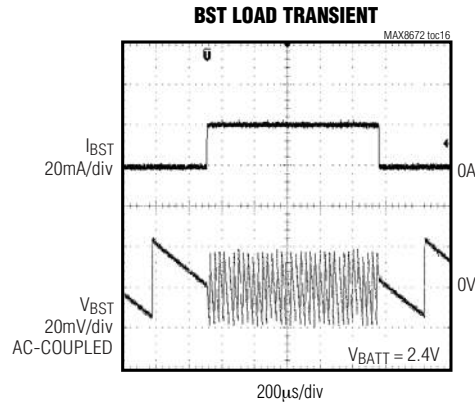
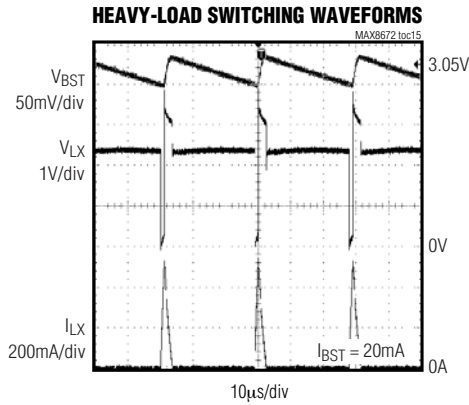

Complete Backup Management IC for NiMH Batteries

Pin Description

MAX8672

PIN	NAME	FUNCTION
1	CT	Programming Input for Charge Timer. Connect a capacitor from CT to GND to program the charge timer (range: 2min to 2000min, nominally programmed to 8h = 480min with $C_{CT} = 0.047\mu\text{F}$).
2	CHGI	Programming Input for the Standard Charge-Current Rate. Connect a resistor (R_{CHGI}) from CHGI to GND to program the standard charge current from 100 μA to 20mA.
3	TRKI	Programming Input for the DC Trickle-Charge Rate. Connect a resistor from TRKI to GND to program the trickle-charge current.
4	BATT	Backup-Battery Connection. The backup battery charges from IN but does not allow reverse current to IN when $V_{IN} < V_{BATT}$. BATT input current is less than 0.1 μA when V_{BATT} is below the UV threshold.
5	IN	Power Input. Range is 2.7V to 5.5V.
6	DR	Programming Input for Deep-Recovery Threshold. The DR output adds charge current when V_{BATT} is below the $V_{BATT(DR)}$ threshold (and THRM is valid) by biasing an external resistor connected from DR to BATT. The DR output voltage, V_{DR} , is 0.816 times the $V_{BATT(CHG)}$ limit set by V_{CHGV} ($V_{DR} = 1.224\text{V}$ for a 1.5V $V_{BATT(CHG)}$). The DR current is sourced in addition to the standard charge current set by R_{CHGI} .
7	UV	Programming Input for the BATT Undervoltage Lockout (UVLO), $V_{BATT(UV)}$. The UVLO threshold is programmed by connecting a resistor from UV to GND. The backup LDO and boost converter cannot start after UVLO occurs, or on power-up, until a valid V_{IN} and V_{BST} are applied. $V_{BATT(UV)}$ is programmable from $V_{BATT} = 0.8\text{V}$ to 3.5V. An open circuit at UV disables the boost and LDO and interrupts battery drain. UVLO also latches off backup circuitry to minimize battery drain.
8	GND	Ground
9	LX	Boost Converter Switch Node. Connect the boost inductor from LX to BATT.
10	BST	Boost Converter Output. BST has reverse current blocking when V_{BST} is higher than V_{IN} or V_{BATT} . The MAX8672 operates with V_{BST} down to 2.35V. The BST output is factory preset for 3.05V for use with 3.3V systems. Other voltages are available on request.
11	LDO	LDO Output. Programmable from 1.5V to 3.05V. LDO has reverse current blocking.
12	FBL	Programming Input for the LDO Output Voltage. Connect FBL to the center of a resistor-divider connected between LDO and GND. The FBL threshold is 1.25V.
13	CHGV	Programming Input for the Charge Voltage Limit ($V_{BATT(CHG)}$). Also programs the trickle threshold ($V_{BATT(TRK)}$), standard charge-restart voltage ($V_{BATT(RSTRT)}$), DR threshold ($V_{BATT(DR)}$), and the DR output voltage (V_{DR}). For NiMH, program 1.5V $V_{BATT(CHG)}$ per cell, so that the max possible voltage is 1.55V per cell with tolerances. $V_{BATT(CHG)}$ is programmable from 1.5V to 3.0V by connecting a resistor from CHGV to GND. When the battery voltage rises to $V_{BATT(CHG)}$, standard charging stops. When the battery voltage falls to $V_{BATT(TRK)}$, trickle charge begins. Standard charge does not resume until the battery voltage falls to $V_{BATT(RSTRT)}$.
14	THRM	External Thermistor Monitor Connection. Connect an NTC (100k Ω at $T_A = +25^\circ\text{C}$) thermistor for -1°C and $+45^\circ\text{C}$ charging cutoff. Only trickle charging is allowed outside the temperature limits. These temperature thresholds are programmable by adding series and parallel resistors to the external thermistor. See Table 1.
—	EP	Exposed Pad. Connect to GND but do not rely on EP for ground functions. This pad is internally connected to ground through a soft connect, meaning there is no internal metal or bond wire physically connecting the exposed pad to the GND pin. Connecting the exposed pad to ground does not remove the requirement for a good ground connection to the appropriate pins. For good thermal dissipation, the exposed pad must be soldered to the power ground plane.

Complete Backup Management IC for NiMH Batteries

Detailed Description

The MAX8672 is a compact IC for managing backup-battery charging and utilization in PDAs and other smart handheld devices. The IC contains three major blocks: a charger for 1 or 2 NiMH coin cells; a small, very-low-quiescent current step-up DC-DC converter that generates a boosted backup supply; and an LDO that can supply a 2nd backup voltage to an additional system block (typically low-voltage RAM).

The MAX8672 does not have a logic control signal for activating backup. The main system supplies are directly connected to the BST and LDO outputs, where LDO and BST are programmed to regulate just below system supply voltages. When system supply voltages exceed the programmed BST and LDO output voltage, BST and LDO are pulled up by the system supplies and do not sink current (BST sinks 80µA for chip operation). When the system supplies fall below the programmed output voltage, BST and LDO operate to maintain system voltages at the programmed values.

The LDO and boost converter do not operate any differently in the system's running (and charging) state than they do in the backup state. The LDO and BST error amplifiers constantly monitor their outputs in both cases.

The MAX8672 has three states:

- **System Active/Charging.** With a valid V_{IN} (greater than 2.7V and also greater than V_{BATT}), and a valid V_{BST} (greater than 2.35V), the battery charges. LDO and BST are active and available for system backup. Charging and system backup are independent functions.
- **Backup.** When the system supply voltages have fallen below the programmed output voltage, BST and LDO maintain their output voltages and are sourced by the battery. Under these conditions, battery charging has ceased, but this is not a requirement for the backup state.
- **Off.** When the battery voltage has fallen below the UVLO threshold ($V_{BATT(UV)}$) and V_{IN} is not valid, the IC turns off and all outputs are latched off. If V_{BATT} recovers to above $V_{BATT(UV)}$, charging does not resume until both a valid V_{IN} and V_{BST} are present. Negligible battery current (less than 50nA leakage) is drawn in this state.

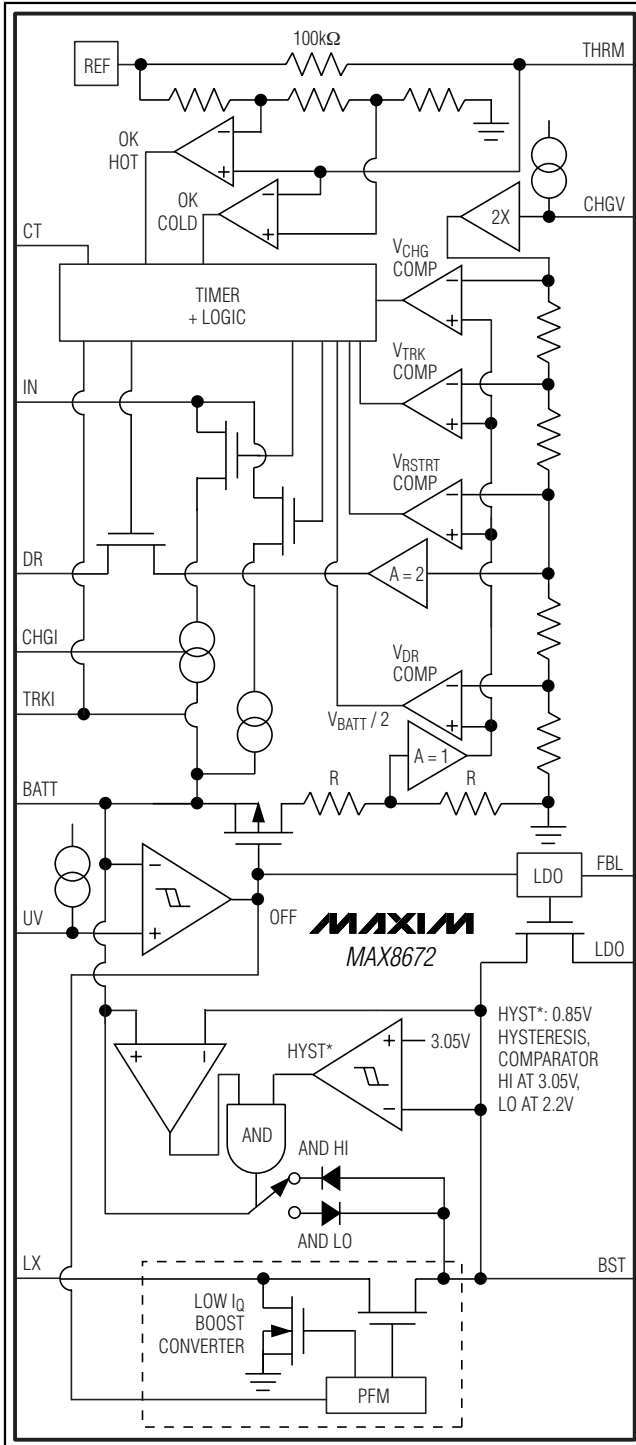

Figure 1. MAX8672 Functional Block Diagram

Complete Backup Management IC for NiMH Batteries

Charger

The MAX8672 charger is a comparator-controlled current source with both current and voltage limits programmed by external resistors. Typical charge profiles for a 1-cell NiMH battery are shown in Figure 2 and explained below.

When power is applied at IN and BST, the MAX8672 charges the battery at the standard charge current programmed by a resistor connected between CHGI and GND. The MAX8672 remains in standard charge until the charge timer (programmed by C_{CT}) times out, the battery rises to the $V_{BATT(CHG)}$ limit, or the charge is interrupted by a temperature-range violation. If standard charge is terminated by the charge timer, trickle charge mode begins and continues without timing until the $V_{BATT(CHG)}$

limit is achieved. Once standard charge or trickle charge is terminated by the $V_{BATT(CHG)}$ limit, charging ceases. Subsequently, if V_{BATT} falls to the $V_{BATT(TRK)}$ threshold, trickle charge is activated. V_{BATT} then rises and the charging cycle continues. The charger does not enter standard charge again until the battery falls to the $V_{BATT(RSTRT)}$ threshold. When the $V_{BATT(RSTRT)}$ threshold is reached, standard charge begins and the charge timer is reset.

Standard charge is also interrupted if the external thermistor temperature sensed at THRM is out of range. When THRM senses a too-hot or too-cold condition during standard charge, the timer pauses and the charger enters trickle charge.

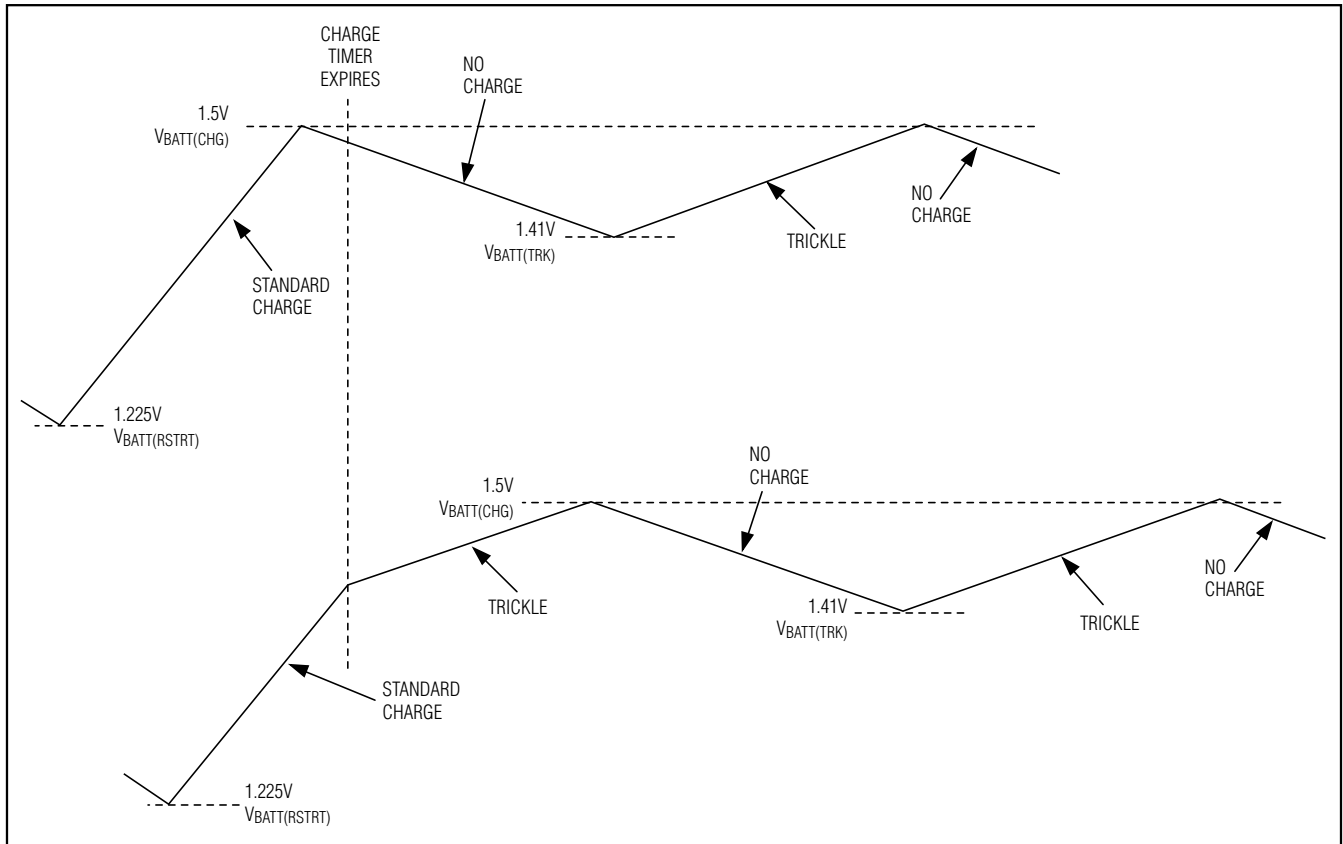

Figure 2. Typical Charge-Current Profiles for 1-Cell Battery

Complete Backup Management IC for NiMH Batteries

Additionally, if V_{IN} is interrupted during standard charge, and the battery voltage is greater than $V_{BATT}(RSTRT)$, the timer pauses until power is reapplied. If the battery voltage falls below $V_{BATT}(RSTRT)$, the timer resets. See the charger state diagram in Figure 3 for more details on charger operation.

Trickle charge occurs whenever standard charge is interrupted by timeout, when V_{BATT} falls to $V_{BATT}(TRK)$, or when $THRM$ senses an out-of-temperature-range condition. Trickle charge has the same voltage limit as standard charge and cannot drive the battery above $V_{BATT}(CHG)$.

A valid voltage is required on both IN and BST for standard and trickle charging. Once charging begins, if V_{IN} becomes invalid, charging stops, but the timer is paused since the backup circuitry is supplying BST . If V_{BST} falls below 2.2V, the timer resets.

If the thermistor hot- or cold-temperature threshold is violated, the charge timer pauses and only trickle charging is allowed. When $THRM$ recovers, the MAX8672 goes to RUN instead of reentering the charge mode. This is done to reevaluate the battery state when the temperature returns to the normal operating range. The charge timer is not reset when returning to the RUN state.

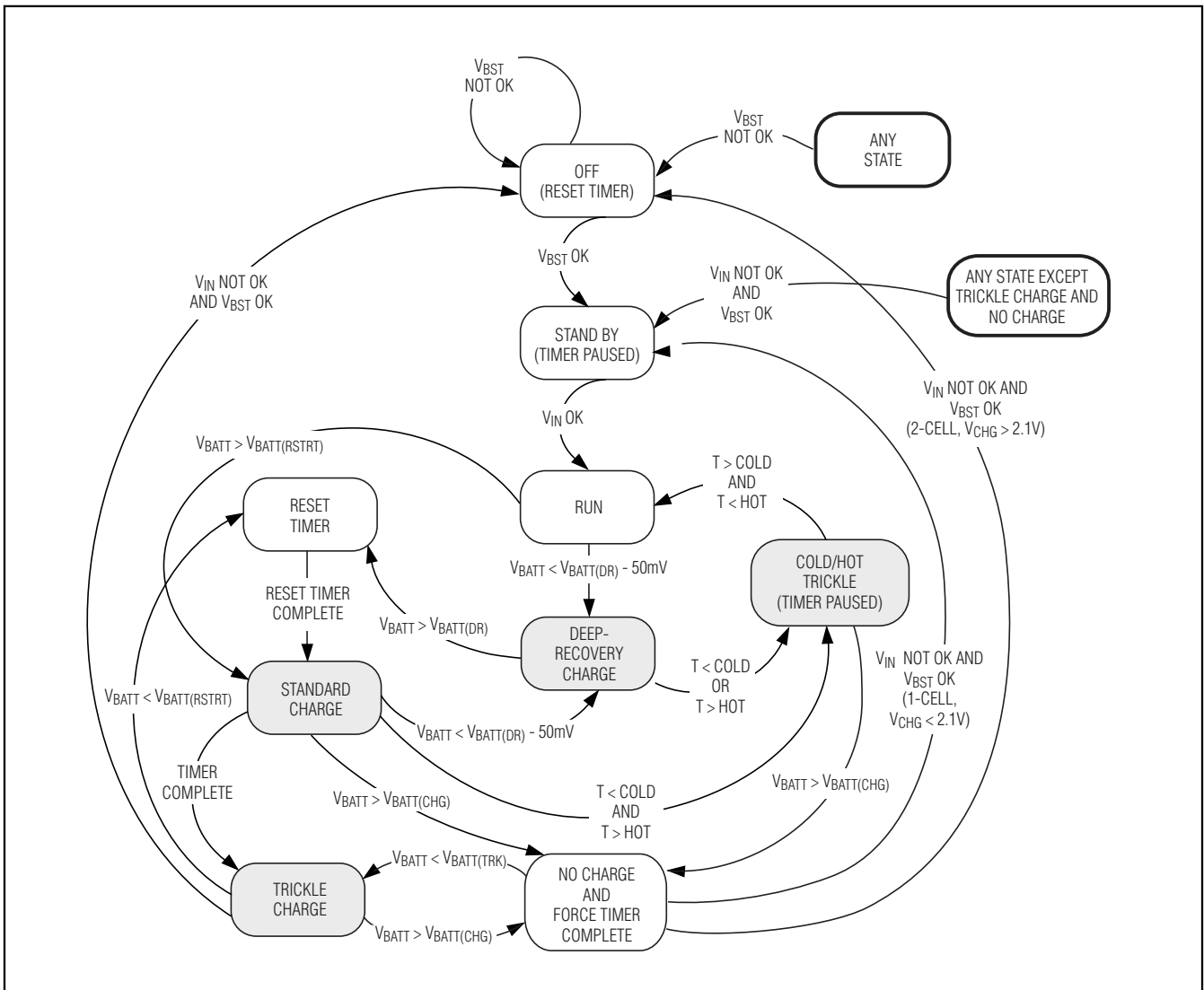

Figure 3. Charger State Diagram

Complete Backup Management IC for NiMH Batteries

MAX8672

Charger Voltage and Standard Charge-Current Limits

The MAX8672 charger is a comparator-controlled current source with both current and voltage limits programmed by external resistors.

The maximum battery charge-voltage limit ($V_{BATT(CHG)}$) is programmed by connecting a resistor (R_{CHGV}) from CHGV to GND (Figure 4). The range for the charging voltage limit is 1.5V to 3.0V. For NiMH batteries, $V_{BATT(CHG)}$ is typically selected for a 1.5V max charge per cell. After selecting $V_{BATT(CHG)}$ for the intended application, the required R_{CHGV} is determined by the following equation:

$$R_{CHGV} = \frac{V_{BATT(CHG)}}{52.265 \times 10^{-6}}$$

(Note that the voltage at CHGV is $V_{BATT(CHG)} / 4$.)

The other voltage thresholds associated with the charging cycle (Figure 2) are dependent upon the selection of $V_{BATT(CHG)}$ as follows:

Falling battery threshold to begin trickle charge ($V_{BATT(TRK)}$):

$$V_{BATT(TRK)} = 0.94 \times V_{BATT(CHG)}$$

Falling battery threshold to restart standard charge ($V_{BATT(RSTRT)}$):

$$V_{BATT(RSTRT)} = 0.816 \times V_{BATT(CHG)}$$

Rising battery threshold to exit deep-recovery charge ($V_{BATT(DR)}$):

$$V_{BATT(DR)} = 0.667 \times V_{BATT(CHG)}$$

Standard charging of the battery occurs when the MAX8672 is first turned on, or when the battery is discharged below the $V_{BATT(RSTRT)}$ threshold. Standard charge ceases when the $V_{BATT(CHG)}$ limit is reached. The standard charge current ($I_{BATT(CHG)}$) is programmed from 0.1mA to 20mA by connecting a resistor (R_{CHGI}) from CHGI to GND (Figure 4). The valid range of R_{CHGI} is 5k Ω to 1M Ω . Once the value of standard charge current ($I_{BATT(CHG)}$) has been chosen, the required R_{CHGI} is determined by the following equation:

$$R_{CHGI}(k\Omega) = \frac{100}{I_{BATT(CHG)}(mA)}$$

Trickle Charge

Trickle charge occurs whenever standard charge is interrupted by timeout, when V_{BATT} falls to $V_{BATT(TRK)}$,

or when THRM senses an out-of-temperature-range condition. Trickle charge has the same voltage limit as standard charge.

The trickle current is programmed from 100 μ A to 1mA by connecting a resistor (R_{TRKI}) from TRKI to GND (Figure 4). After selecting the battery trickle charge current ($I_{BATT(TRK)}$) for the application, R_{TRKI} is determined by the following equation:

$$R_{TRKI}(k\Omega) = \frac{100}{I_{BATT(TRK)}(mA)}$$

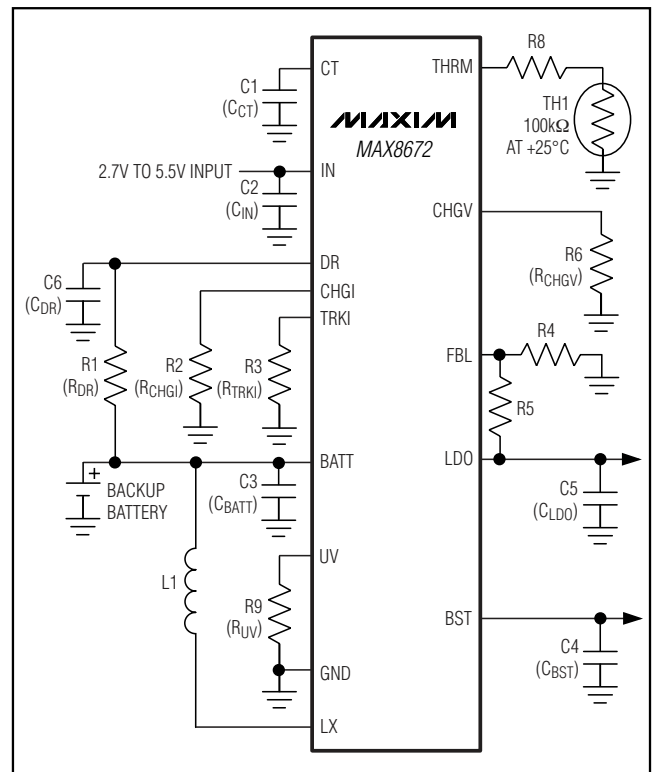

Figure 4. External Component Diagram

Deep-Recovery Charge

The MAX8672 includes a circuit to bring up deep discharged NiMH cells. When power is first applied to IN, if the battery voltage is less than the battery deep-recovery threshold, $V_{BATT(DR)}$, DR connects an internally regulated voltage to an external resistor that sources extra current into the battery. The DR current-limiting resistor is typically selected for a 0.5C charge rate when the cell voltage is 0V. When DR is on, both the standard charge current and the DR current charge the battery. When the cell voltage reaches $V_{BATT(DR)}$, DR current is turned off and standard charging begins.

Complete Backup Management IC for NiMH Batteries

DR charging is allowed only when the THRM temperature is within hot and cold limits. The rising battery-voltage threshold for DR ($V_{BATT(DR)}$) is given by the following equation:

$$V_{BATT(DR)} = 0.667 \times V_{BATT(CHG)}$$

The DR output voltage is:

$$V_{DR} = 0.816 \times V_{BATT(CHG)}$$

Thermistor Monitor

The thermistor monitor suspends standard charging (and pauses the standard charge timer) when the thermistor temperature moves above +45°C or below -1°C. The thermistor must be an NTC type with a nominal +25°C resistance of 100kΩ.

The temperature trip thresholds are adjusted by adding external resistors in series and in parallel with the thermistor. For the specified thermistor, the resistors values are shown in Table 1.

Table 1. Series/Parallel Resistors for Different Thermistor Thresholds (β)

SERIES R (kΩ)	PARALLEL R (MΩ)	HOT TEMP (°C)	COLD TEMP (°C)
0	None	45	-1
7.5	None	50	-0.6
13.7	None	55	-0.3
18.7	None	60	0
18.8	6.8	59.9	-1
22.7	None	65	0
23	5.6	65	-1
8.6	1.7	50	-5

Note: With 100kΩ thermistors at +25°C, $\beta = 3977$.

Charge Timer

The MAX8672 includes a charge timer that is programmable from 2min to 2000min. Timer duration is programmed by a capacitor, C_{CT} , connected from CT to GND (Figure 4). The charge-timer duration (t_{CHG}) is determined by the equation:

$$t_{CHG} \text{ (minutes)} = 10195 \times C_{CT} \text{ (}\mu\text{F)}$$

Boost DC-DC Converter

The MAX8672 contains a low-current synchronous-rectified boost converter that can supply up to 20mA. The boost converter's preset output voltage is 3.05V, intended for backing up a 3.3V supply. Preset output voltages can be obtained from the factory on request. Generally, the output voltage is programmed to be just

below the minimum tolerance for the main supply. When the main supply voltage drops below its specified level, the step-up converter begins regulating as long as the load is 20mA or less. The MAX8672 blocks reverse current flow if V_{BST} is higher than V_{BATT} .

The MAX8672 typical application expects that a valid system voltage is connected to BST and IN before backup operations are required. The boost DC-DC converter is able to supply a system load (up to 20mA) when the main power source falls below the BST preset voltage, but the IC cannot start up the BST output with just the backup battery alone. BST must initially be powered by the external system in order for the boost converter to start. Then, if the system voltage falls below the BST preset voltage, the boost converter can supply the load. If necessary, this limitation can be overcome for some applications by connecting a diode from IN to BST, so that BST is immediately powered from IN.

When V_{BATT} is less than V_{BST} , and V_{BST} is not externally pulled above 3.05V by the main system supply, the boost converter runs as needed to maintain V_{BST} at 3.05V. If, during normal active/charging mode operation, V_{BATT} rises above the main system voltage that is connected to BST, current may flow from the battery to the main system supply, even though no backup operation is expected. For example, in a 2-cell system, if V_{BATT} is 3.2V and the system supply is holding BST at 3.1V, then the backup battery drains into the system supply. The boost synchronous rectifier pMOS contains a body diode that is switched to prevent unwanted current flow (see the *BATT-BST Current Flow* section).

Since the normal maximum charge limit ($V_{BATT(CHG)}$) for 2 NiMH cells is usually set to 3.0V (for a 3.1V max), and a 3.3V system supply less a 5% tolerance is 3.135V, V_{BATT} does not exceed V_{BST} during normal system operation, resulting in no backup current flow. However, for other BATT or BST voltages where unwanted backup current flow may occur, it can be prevented by connecting a diode in series with the boost inductor to reduce the voltage at BST. The diode may be a Schottky or silicon signal diode, depending on how much voltage needs to be dropped.

Boost Output Capacitor Selection

Choose output capacitors to supply output peak currents with acceptable voltage ripple. Low equivalent series resistance (ESR) capacitors are recommended. Ceramic capacitors have the lowest ESR, but low-ESR tantalum or polymer capacitors offer a good balance between cost and performance.

Complete Backup Management IC for NiMH Batteries

LDO

Output-voltage ripple has two components: variations in the charge stored in the output capacitor (C_{BST}) with each BST pulse, and the voltage drop across the capacitor's ESR due to the current flow into and out of the capacitor. The equations for approximating output-voltage ripple are:

$$V_{RIPPLE} = V_{RIPPLE(C)} + V_{RIPPLE(ESR)}$$

$$V_{RIPPLE(ESR)} = I_{PEAK} \times R_{ESR}$$

$$V_{RIPPLE(C)} = \frac{1}{2} \left(\frac{L}{(V_{BST} - V_{BATT}) \times C_{BST}} \right) I_{PEAK}^2$$

where I_{PEAK} is the peak inductor current (see the *Boost Inductor Selection* section). Since ESR is usually very small in ceramic capacitors, the output ripple is typically dominated by $V_{RIPPLE(C)}$.

Capacitance and ESR variation with temperature should be considered for best performance in applications with wide operating-temperature ranges.

Boost Inductor Selection

The control scheme of the MAX8672 permits flexibility in choosing an inductor. A 4.7 μ H inductor performs well in most applications.

For maximum output current, choose the inductor value so that the controller reaches the current limit before the maximum on-time is reached:

$$L < \frac{V_{BATT} \times t_{ON(MAX)}}{I_{LIM}}$$

where $t_{ON(MAX)}$ is typically 5 μ s, and the current limit (I_{LIM}) is typically 500mA (see the *Electrical Characteristics*).

For larger inductor values, determine the peak inductor current (I_{PEAK}) by:

$$I_{PEAK} = \frac{V_{BATT} \times t_{ON(MAX)}}{L}$$

For backup designs that require two different backup voltages, the MAX8672 includes a small LDO, which is powered from BST. This LDO can supply up to 20mA.

Generally, the output voltage is programmed to be just below the minimum tolerance for the main supply. When the main supply voltage drops below its specified level, the LDO begins regulating.

The LDO output voltage is adjustable from 1.5V to 3.05V using external resistors (R_4 and R_5 in Figure 4). Since the FBL input bias current is 50nA (max), select feedback resistor R_4 in the 100k Ω to 1M Ω range. After choosing R_4 , calculate R_5 as follows:

$$R_5 = R_4 \left[\frac{V_{LDO}}{V_{FBL}} - 1 \right]$$

where $V_{FBL} = 1.25V$.

Backup-Battery Bypass Capacitor Selection

The MAX8672 boost converter draws 500mA short-term inductor-charging current peaks from the battery when the boost converter operates. Small coin cells that are commonly used for backup often exhibit high output impedance that varies over temperature. For this reason, the backup battery must be bypassed with a high-quality ceramic capacitor with X7R, X5R, or better dielectric (C_{BATT} , Figure 4). Typical values are between 10 μ F and 47 μ F. Note that high battery ripple can prematurely trigger the UVLO comparator and shut down the boost circuit before the battery is fully discharged. If this is a concern with the selected battery, the UV threshold may be lowered, in addition to using a larger battery bypass capacitance, to accommodate the short-term battery-voltage dip due to ripple. See the Battery Ripple vs. Temperature graph in the *Typical Operating Characteristics* section.

Complete Backup Management IC for NiMH Batteries

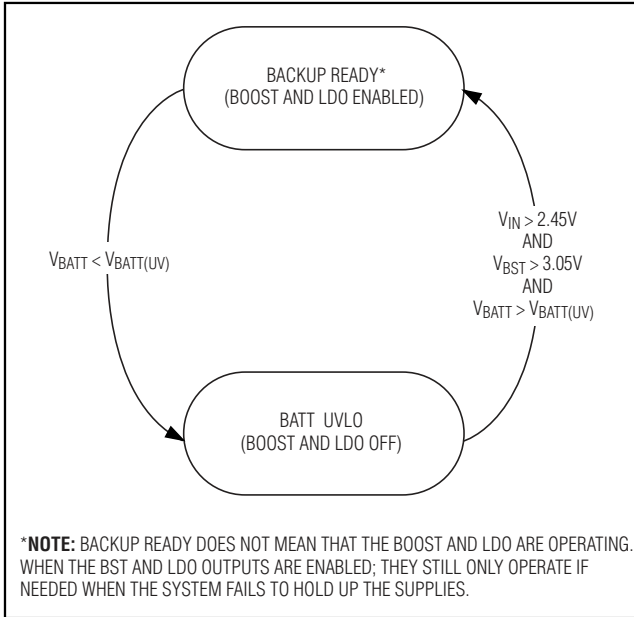

Figure 5. Backup and BATT UVLO State Diagram

BATT Undervoltage Lockout

When the backup battery discharges to a programmed threshold, $V_{BATT(UV)}$, BATT UVLO is engaged. As a result, the MAX8672 backup functions (BST and LDO) shut down, and a small current (less than 50nA) is drawn from BATT. During BATT UVLO, charge functions still remain active to recharge the battery. Once BATT UVLO occurs, the backup boost converter and LDO do not reactivate until V_{BST} rises above 3.05V and V_{IN} rises above 2.45V (typ). Even if BATT recovers, the backup functions do not activate until a valid V_{IN} and V_{BST} have been present. See the *Backup and BATT UVLO State Diagram* (Figure 5).

The BATT UVLO threshold ($V_{BATT(UV)}$) is programmed by connecting a resistor (R_{UV}) from UV to GND (Figure 4). For NiMH cells, the UVLO threshold is typically programmed to 0.8V per cell. Once the UVLO threshold value is determined, R_{UV} is calculated from the following equation:

$$R_{UV} = \frac{V_{BATT(UV)}}{16 \times 10^{-6}}$$

Note: In order for BATT current to remain below 50nA during BATT UVLO, V_{BST} must fall below 0.5V. If V_{BST} is held up by another source during UVLO, or if V_{BST} is higher than 0.5V, BATT input current during BATT UVLO is typically 500nA. Typically, V_{BST} falls to 0V in most situations. If minimum battery drain during BATT UVLO is critical, then an external pulldown resistor connected between BST and GND may be needed to discharge the BST output.

The 500nA BATT drain during UVLO is necessary when V_{BST} is > 0.5V because a comparator must be kept active in order to detect the higher of V_{BATT} or V_{BST} . This comparator switches the body diode of the internal FET connecting these outputs to ensure that current flow is blocked. When V_{BST} falls to approximately 0.5V, the comparator is shut off, and the FET body is connected to block current flowing from BATT to BST.

BATT-BST Current Flow

The MAX8672 synchronous rectifier pMOS contains an internal body diode connected between BATT and BST. This diode switches to prevent undesired current flow between these pins. Upon startup, the body diode points to the greater of V_{BATT} or V_{BST} , until V_{BST} rises above 3.05V (at least once). Then the body diode switches to point to BST. The body diode points from BATT to BST until V_{BST} falls below 2.2V. When this occurs, the body diode switches to point to the greater of V_{BATT} or V_{BST} .

If V_{BATT} exceeds V_{BST} by a few hundred millivolts or more, the body diode is forward biased and current flows from BATT to BST. This is the typical case for a boost converter when the input exceeds the output. When backing up, this typically is not a problem since it is expected that battery current powers the system.

When not in backup mode (system power is up and is pulling V_{BST} over 3.05V), current can flow from BATT to BST if V_{BATT} exceeds V_{BST} by enough to forward bias the diode. With two NiMH cells, V_{BATT} charges to 3.0V nominal (3.1V max), so with V_{BST} pulled to more than 3.05V by the system, there is not enough voltage difference to cause significant current to flow from BATT to BST.

Complete Backup Management IC for NiMH Batteries

MAX8672

Applications Information

Typical Application Circuit

Figure 6 displays the MAX8672 typical application circuit for 2-cell NiMH applications. Corresponding to the requirements for 2-cell NiMH batteries, maximum charge voltage is programmed for 3.0V and the UVLO threshold is set to 1.6V. The LDO output voltage is 1.75V. Standard charge provides 2mA of standard charge current, while trickle charge is programmed to provide 500 μ A of trickle charge current. A 7.5k Ω resistor is connected in series with the thermistor to program a hot temperature threshold of +50 $^{\circ}$ C and a cold temperature threshold of -0.6 $^{\circ}$ C.

Layout Guidelines

Careful PCB layout is important for minimizing ground bounce and noise. Ensure that C2 (IN input capacitor), C3 (BATT input capacitor), C4 (BST bypass capacitor), and C5 (LDO output capacitor) are placed as close as possible to the IC. Avoid using vias to connect C3 or C4 to their respective pins or GND. C3 and C4 grounds should be located next to each other, and this connection can then be used as the star ground point. All other grounds should connect to the star ground. Connect EP to the bottom layer ground plane, and then connect the ground plane to the star ground. Vias on the inductor path are acceptable, if necessary. IN, BATT, BST, and LDO traces should be as wide as possible to minimize inductance. Refer to the MAX8672 evaluation kit for a PCB layout example.

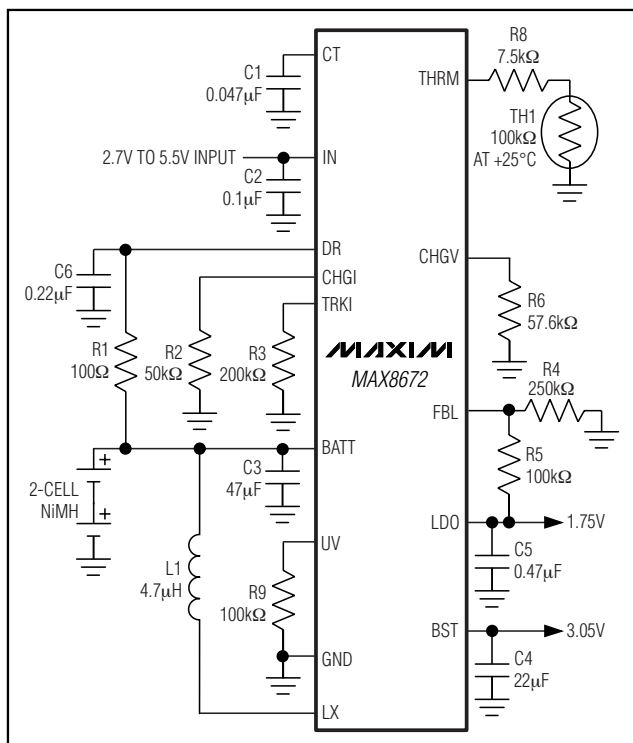

Figure 6. Typical Application Circuit for the MAX8672 Using a 2-Cell NiMH

Chip Information

PROCESS: BiCMOS

Complete Backup Management IC for NiMH Batteries

Package Information

(The package drawing(s) in this data sheet may not reflect the most current specifications. For the latest package outline information go to www.maxim-ic.com/packages.)

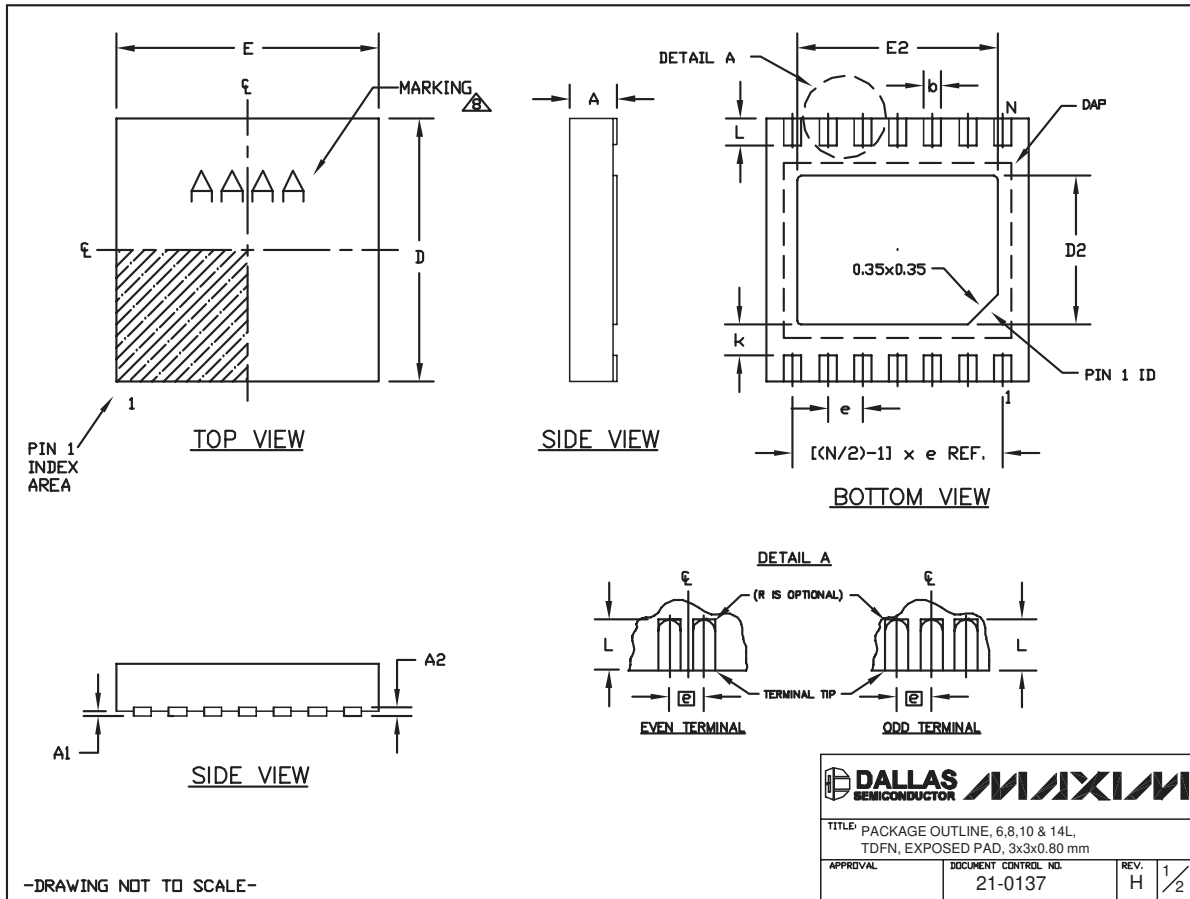

6, 8, & 10L, DFN THINLEPS

Complete Backup Management IC for NiMH Batteries

Package Information (continued)

(The package drawing(s) in this data sheet may not reflect the most current specifications. For the latest package outline information go to www.maxim-ic.com/packages.)

MAX8672

COMMON DIMENSIONS		
SYMBOL	MIN.	MAX.
A	0.70	0.80
D	2.90	3.10
E	2.90	3.10
A1	0.00	0.05
L	0.20	0.40
k	0.25 MIN.	
A2	0.20 REF.	

PACKAGE VARIATIONS								
PKG. CODE	N	D2	E2	e	JEDEC SPEC	b	[(N/2)-1] x e	
T633-1	6	1.50±0.10	2.30±0.10	0.95 BSC	MO229 / WEEA	0.40±0.05	1.90 REF	
T633-2	6	1.50±0.10	2.30±0.10	0.95 BSC	MO229 / WEEA	0.40±0.05	1.90 REF	
T833-1	8	1.50±0.10	2.30±0.10	0.65 BSC	MO229 / WEEC	0.30±0.05	1.95 REF	
T833-2	8	1.50±0.10	2.30±0.10	0.65 BSC	MO229 / WEEC	0.30±0.05	1.95 REF	
T833-3	8	1.50±0.10	2.30±0.10	0.65 BSC	MO229 / WEEC	0.30±0.05	1.95 REF	
T1033-1	10	1.50±0.10	2.30±0.10	0.50 BSC	MO229 / WEED-3	0.25±0.05	2.00 REF	
T1033-2	10	1.50±0.10	2.30±0.10	0.50 BSC	MO229 / WEED-3	0.25±0.05	2.00 REF	
T1433-1	14	1.70±0.10	2.30±0.10	0.40 BSC	----	0.20±0.05	2.40 REF	
T1433-2	14	1.70±0.10	2.30±0.10	0.40 BSC	----	0.20±0.05	2.40 REF	

NOTES:

1. ALL DIMENSIONS ARE IN mm. ANGLES IN DEGREES.
 2. COPLANARITY SHALL NOT EXCEED 0.08 mm.
 3. WARPAGE SHALL NOT EXCEED 0.10 mm.
 4. PACKAGE LENGTH/PACKAGE WIDTH ARE CONSIDERED AS SPECIAL CHARACTERISTIC(S).
 5. DRAWING CONFORMS TO JEDEC MO229, EXCEPT DIMENSIONS "D2" AND "E2", AND T1433-1 & T1433-2.
 6. "N" IS THE TOTAL NUMBER OF LEADS.
 7. NUMBER OF LEADS SHOWN ARE FOR REFERENCE ONLY.
-  MARKING IS FOR PACKAGE ORIENTATION REFERENCE ONLY.

		
TITLE: PACKAGE OUTLINE, 6.8,10 & 14L, TDFN, EXPOSED PAD, 3x3x0.80 mm		
APPROVAL	DOCUMENT CONTROL NO. 21-0137	REV. H 2/2

-DRAWING NOT TO SCALE-

Maxim cannot assume responsibility for use of any circuitry other than circuitry entirely embodied in a Maxim product. No circuit patent licenses are implied. Maxim reserves the right to change the circuitry and specifications without notice at any time.

Maxim Integrated Products, 120 San Gabriel Drive, Sunnyvale, CA 94086 408-737-7600 _____ 17