

THIS DRAWING IS UNPUBLISHED. RELEASED FOR PUBLICATION
 © COPYRIGHT BY TYCO ELECTRONICS CORPORATION. ALL RIGHTS RESERVED.

LOC	DIST	REVISIONS					
		P	LTR	DESCRIPTION	DATE	DWN	APVD
CM	0	G		REVISED PER ECR-15-010337	23JUL2015	RK	SC

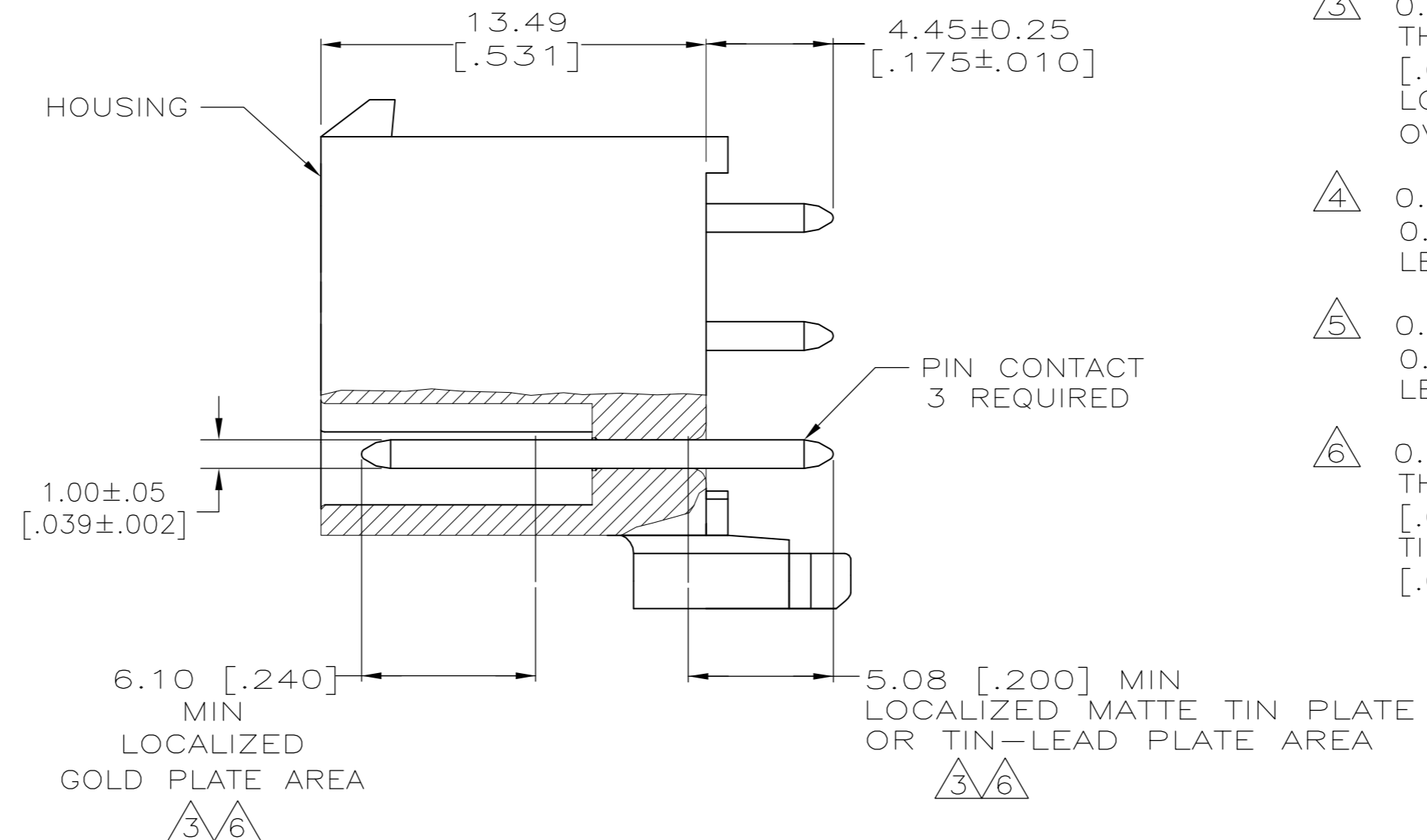

- PINS TO COMPLY WITH AMP SOLDERABILITY SPEC. 109-11-3.
- DIMENSIONS SHOWN IN BRACKETS ARE IN INCHES.
- 0.00076 [.000030] MIN GOLD PLATE IN THE LOCALIZED GOLD PLATE AREA, 0.00381 [.000150] MATTE TIN LEAD IN THE LOCALIZED TIN LEAD PLATE AREA, BOTH OVER 0.00127 [.000050] MIN NICKEL.
- 0.00381 [.000150] MATTE TIN LEAD OVER 0.00127 [.000050] MIN NICKEL ENTIRE LENGTH OF PIN.
- 0.00381 [.000150] MATTE TIN OVER 0.00127 [.000050] MIN NICKEL ENTIRE LENGTH OF PIN.
- 0.00076 [.000030] MIN GOLD PLATE IN THE LOCALIZED GOLD PLATE AREA, 0.00381 [.000150] MATTE TIN IN THE LOCALIZED TIN PLATE AREA, BOTH OVER 0.00127 [.000050] MIN NICKEL.

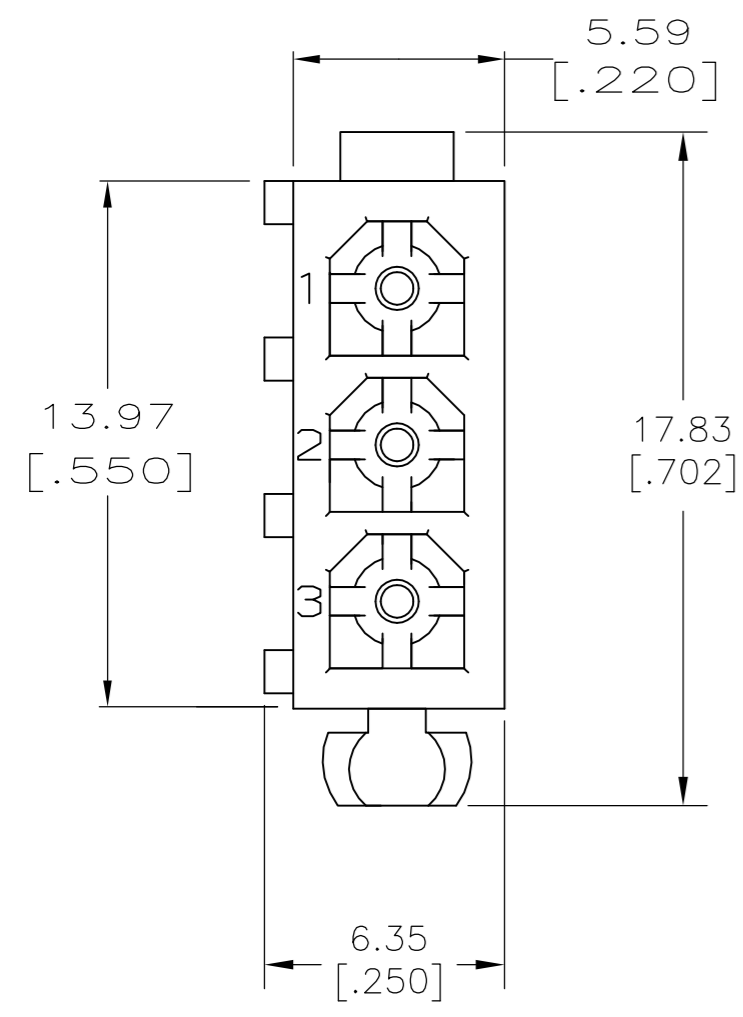
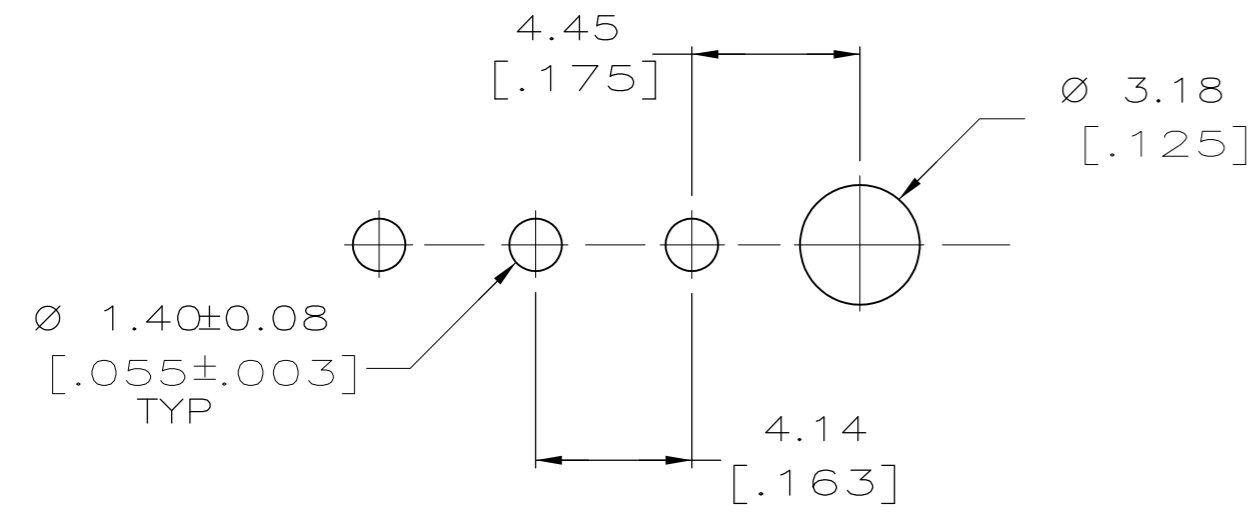

RECOMMENDED LAYOUT FOR 1.57 [.062] THICK BOARD
 TOLERANCES NON-ACCUMULATIVE

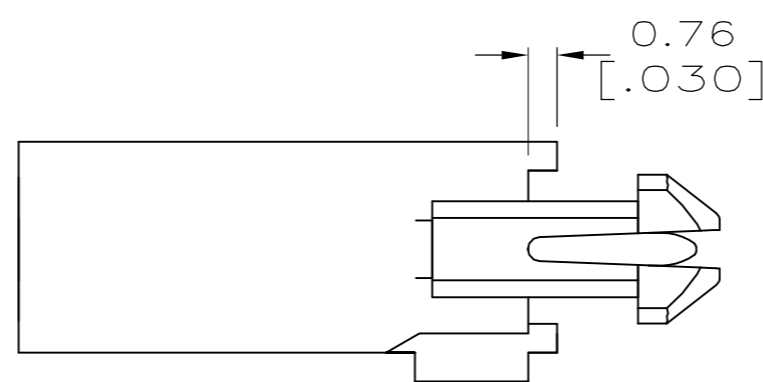

MATERIAL	FINISH	MATERIAL	COLOR	PART NO.
BRASS	6	NYLON, UL94V-0	WHITE	1-770873-1
BRASS	5	NYLON, UL94V-0	WHITE	1-770873-0
BRASS	3	NYLON, UL94V-0	WHITE	770873-2
BRASS	4	NYLON, UL94V-0	WHITE	770873-1

THIS DRAWING IS A CONTROLLED DOCUMENT.

DWN	S CARPENTER	08JUN05
CHK	R JONES	29JUL2003
APVD	R JONES	29JUL2003

TE Connectivity

NAME: HEADER ASSEMBLY
 CLOSED BOTTOM, 3 CKT,
 MINI UNIVERSAL MATE-N-LOK

SIZE	A2	CAGE CODE	00779	DRAWING NO	C=770873	RESTRICTED TO	-
SCALE	5:1	SHEET	1	OF	1	REV	G

CUSTOMER DRAWING

770873