

THIS DRAWING IS UNPUBLISHED.

RELEASED FOR PUBLICATION

© COPYRIGHT BY ALL RIGHTS RESERVED.

LOC	DIST	REVISIONS				
P	LTR	DESCRIPTION	DATE	DWN	APVD	
FB	00	B1	REVISED PER ECO-11-005033	2APR11	RK	HMR

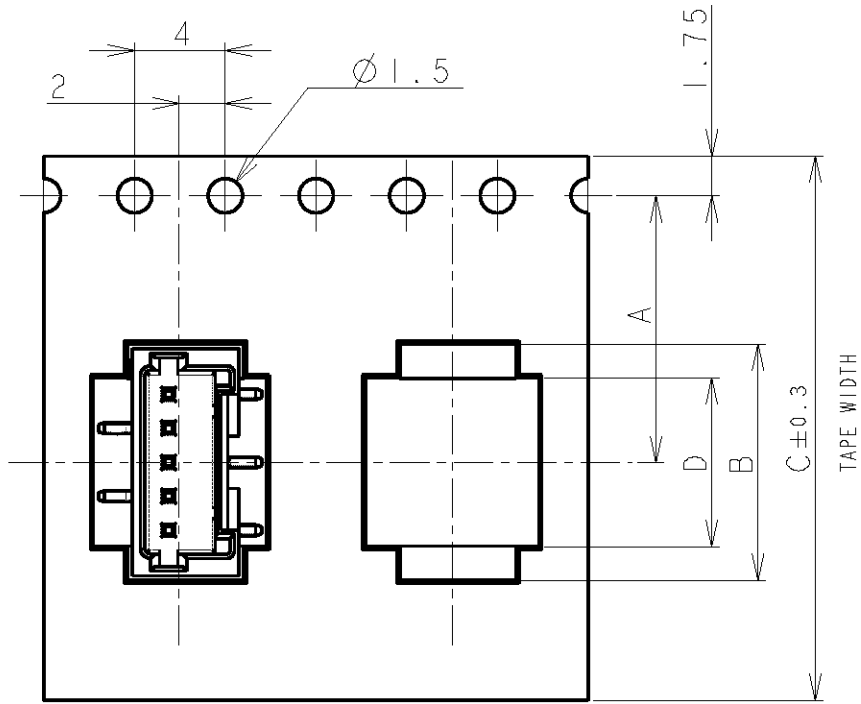

TYPE 1

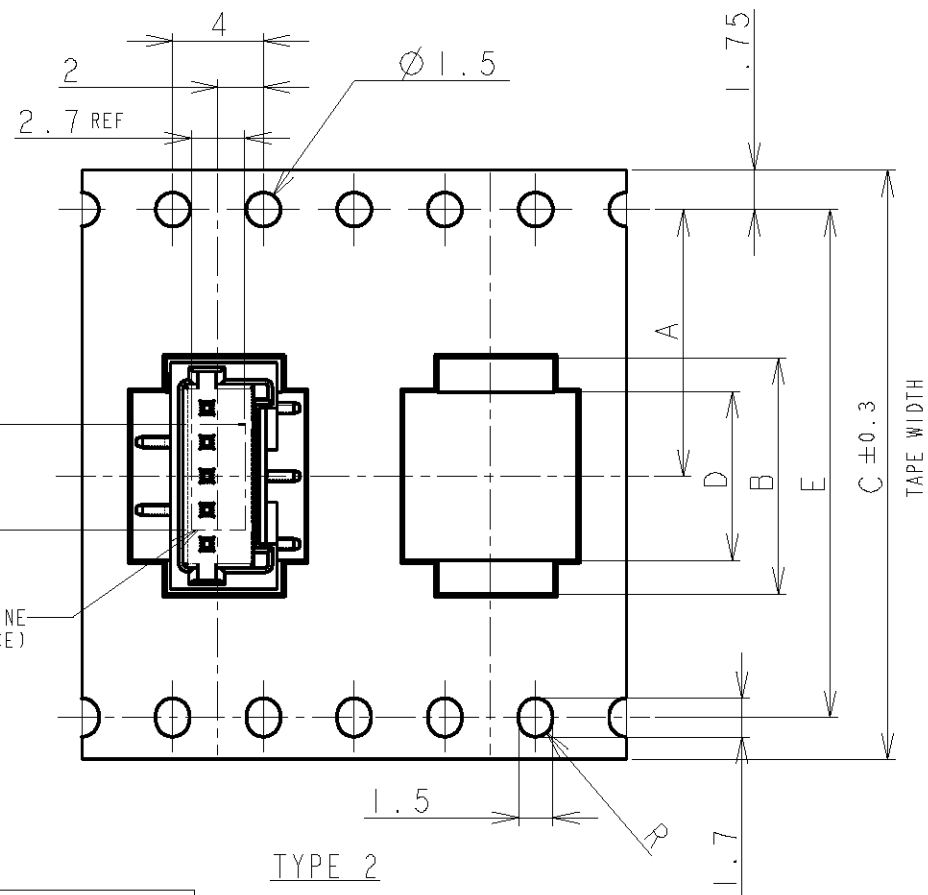

TYPE 2

NOTE:
 1. PEELING STRENGTH: 0.20-0.69N (20-70gf)
 PEELING ANGLE: 165-180°
 PEELING SPEED: 300mm/MINUTE.

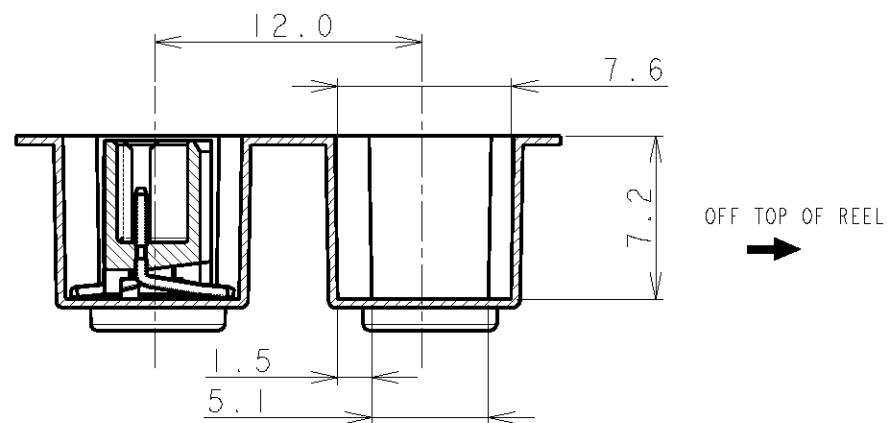
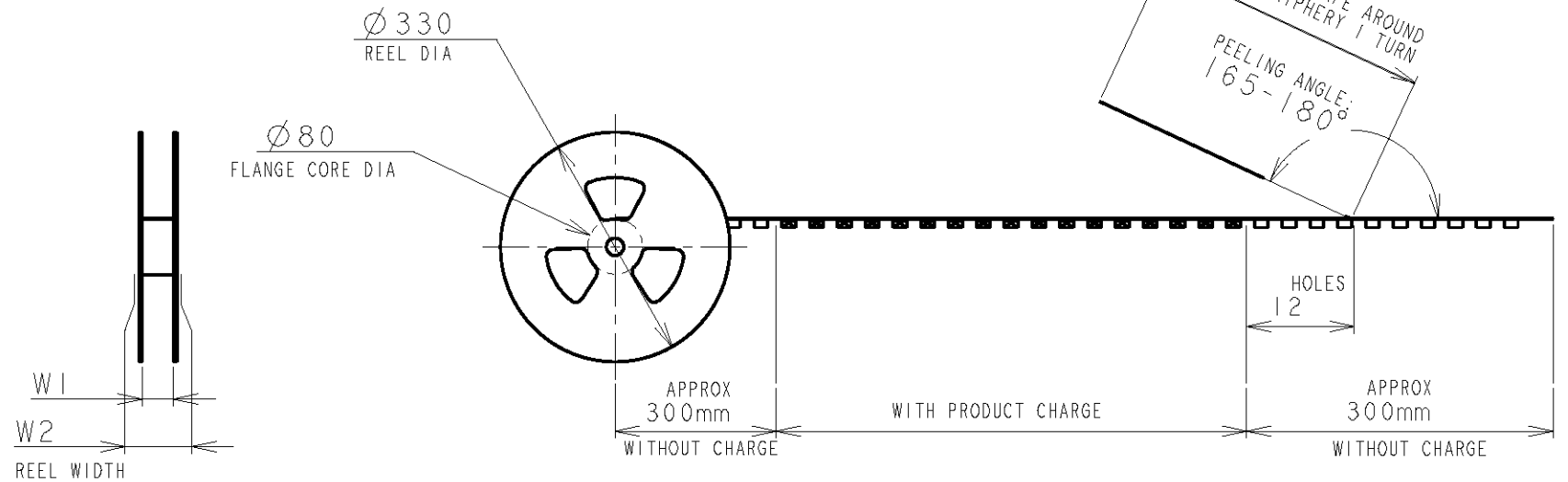
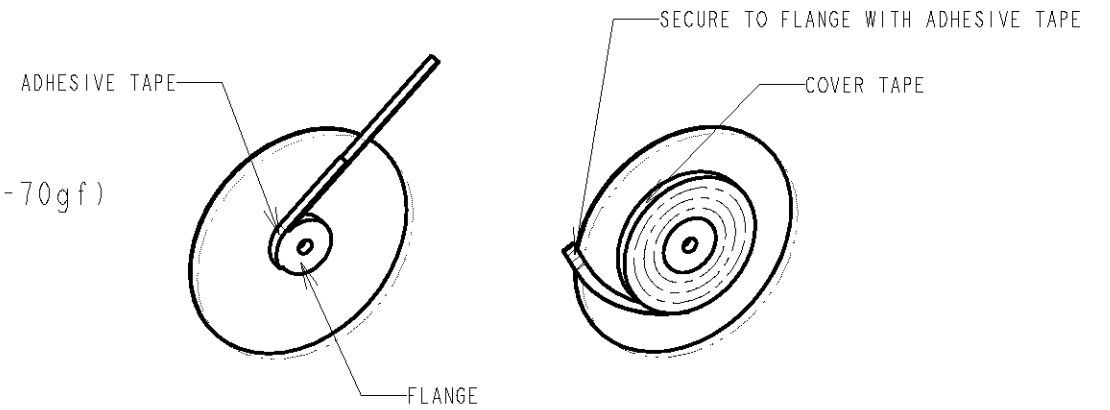

VACUUM NOZZLE OUTLINE (FOR REFERENCE)

TOLERANCES UNLESS OTHERWISE SPECIFIED:

- 10 > : ±0.2
- 30 > * > 10 : ±0.25
- 100 > * > 30 : ±0.3
- ANGLE : ±3°

DWN S.XU 31JAN03		STE TE Connectivity	
CHK S.YAO 31JAN03			
APVD T.SASAKI 31JAN03		NAME AMP Mini Common Terminated (CT) Connector 1.5mm PITCH SINGLE ROW POST HDR ASS'Y (V) SMT TYPE WITH BOSS, EMBOSS TAPE PACKAGED	
PRODUCT SPEC 108-60018		SIZE A3	CAGE CODE 00779
APPLICATION SPEC 114-5223		DRAWING NO C-292230	RESTRICTED TO -
MATERIAL - FINISH -		SCALE NON	SHEET 1 OF 4
CUSTOMER DRAWING		REV B1	

THIS DRAWING IS UNPUBLISHED.

ALL RIGHTS RESERVED.

© COPYRIGHT BY

LOC	DIST	REVISIONS						
FB	00	P	LTR	DESCRIPTION	DATE	DWN	APVD	
				SEE SHEET 1				

TAPE TYPE	TYPE 2	W2	W1	F	E	D	C	B	A	QTY/REEL	POS	COLOR	ON TAPE P/N	
		DIMENSIONS												
		49.5	45.5	6.2	40.4	29.9	44	32.9	20.2±0.15	500	20	BLACK	7-292230-0	
		49.5	45.5	4.7	40.4	28.4	44	31.4		500	19		6-292230-9	
		49.5	45.5	6.2	40.4	26.9	44	29.9		500	18		6-292230-8	
		49.5	45.5	4.7	40.4	25.4	44	28.4		500	17		6-292230-7	
		49.5	45.5	6.2	40.4	23.9	44	26.9		500	16		6-292230-6	
		49.5	45.5	4.7	40.4	22.4	44	25.4		500	15		6-292230-5	
		49.5	45.5	6.2	40.4	20.9	44	23.9		500	14		6-292230-4	
		49.5	45.5	4.7	40.4	19.4	44	22.4		500	13		6-292230-3	
		37.5	33.5	6.2	28.4	17.9	32	20.9		14.2	500		12	6-292230-2
		37.5	33.5	4.7	28.4	16.4	32	19.4		14.2	500		11	6-292230-1
		37.5	33.5	6.2	28.4	14.9	32	17.9	14.2	500	10	6-292230-0		
		37.5	33.5	4.7	28.4	13.4	32	16.4	14.2	500	9	5-292230-9		
	TYPE 1	29.5	25.5	6.2	-	11.9	24	14.9	11.5	500	8	5-292230-8		
		29.5	25.5	4.7	-	10.4	24	13.4	11.5	500	7	5-292230-7		
		29.5	25.5	6.2	-	8.9	24	11.9	11.5	500	6	5-292230-6		
		29.5	25.5	4.7	-	7.4	24	10.4	11.5	500	5	5-292230-5		
		21.5	17.5	6.2	-	5.9	16	8.9	7.5	500	4	5-292230-4		
		21.5	17.5	4.7	-	4.4	16	7.4	7.5	500	3	5-292230-3		
		21.5	17.5	2.8	-	2.9	16	5.9	7.5	500	2	-		
TAPE TYPE		W2	W1	F	E	D	C	B	A	QTY/REEL	POS	COLOR	ON TAPE P/N	
		DIMENSIONS												

TAPE TYPE	TYPE 2	W2	W1	F	E	D	C	B	A	QTY/REEL	POS	COLOR	ON TAPE P/N	
		DIMENSIONS												
		49.5	45.5	6.2	40.4	29.9	44	32.9	20.2±0.15	500	20	BEIGE	2-292230-0	
		49.5	45.5	4.7	40.4	28.4	44	31.4		500	19		1-292230-9	
		49.5	45.5	6.2	40.4	26.9	44	29.9		500	18		1-292230-8	
		49.5	45.5	4.7	40.4	25.4	44	28.4		500	17		1-292230-7	
		49.5	45.5	6.2	40.4	23.9	44	26.9		500	16		1-292230-6	
		49.5	45.5	4.7	40.4	22.4	44	25.4		500	15		1-292230-5	
		49.5	45.5	6.2	40.4	20.9	44	23.9		500	14		1-292230-4	
		49.5	45.5	4.7	40.4	19.4	44	22.4		500	13		1-292230-3	
		37.5	33.5	6.2	28.4	17.9	32	20.9		14.2	500		12	1-292230-2
		37.5	33.5	4.7	28.4	16.4	32	19.4		14.2	500		11	1-292230-1
		37.5	33.5	6.2	28.4	14.9	32	17.9	14.2	500	10	1-292230-0		
		37.5	33.5	4.7	28.4	13.4	32	16.4	14.2	500	9	292230-9		
	TYPE 1	29.5	25.5	6.2	-	11.9	24	14.9	11.5	500	8	292230-8		
		29.5	25.5	4.7	-	10.4	24	13.4	11.5	500	7	292230-7		
		29.5	25.5	6.2	-	8.9	24	11.9	11.5	500	6	292230-6		
		29.5	25.5	4.7	-	7.4	24	10.4	11.5	500	5	292230-5		
		21.5	17.5	6.2	-	5.9	16	8.9	7.5	500	4	292230-4		
		21.5	17.5	4.7	-	4.4	16	7.4	7.5	500	3	292230-3		
		21.5	17.5	2.8	-	2.9	16	5.9	7.5	500	2	-		
TAPE TYPE		W2	W1	F	E	D	C	B	A	QTY/REEL	POS	COLOR	ON TAPE P/N	
		DIMENSIONS												

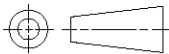
DIMENSIONS: mm	DWN	MATERIAL	FINISH
TOLERANCES UNLESS OTHERWISE SPECIFIED:	CHK	 TE Connectivity	
0 PLC ±-	APVD		
1 PLC ±0.1	PRODUCT SPEC	NAME AMP Mini Common Terminated (CT) Connector 1.5mm PITCH	
2 PLC ±0.01	SEE SHEET 1 OF 4	SINGLE ROW POST HDR ASS'Y (V)	
3 PLC ±0.001	APPLICATION SPEC	SMT TYPE WITH BOSS, EMBOSS TAPE PACKAGED	
4 PLC ±0.0001	SEE SHEET 1 OF 4	SIZE	RESTRICTED TO
ANGLES ±-	WEIGHT	CAGE CODE	DRAWING NO
		A4	00779
CUSTOMER DRAWING		G-292230	
		SCALE	SHEET
		NON	2 OF 4
			REV
			B1

THIS DRAWING IS UNPUBLISHED.

RELEASED FOR PUBLICATION

© COPYRIGHT BY ALL RIGHTS RESERVED.

LOC	DIST	REVISIONS			
P	LTR	DESCRIPTION	DATE	DWN	APVD
FB	00	SEE SHEET 1			

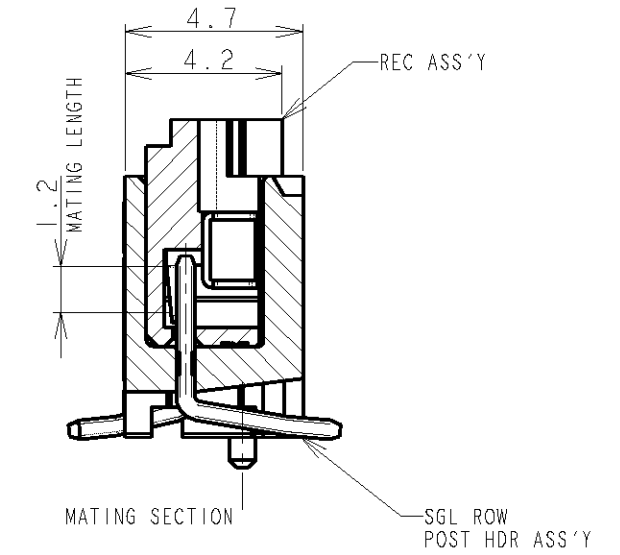
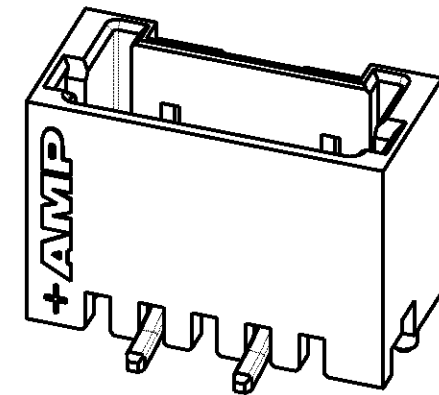
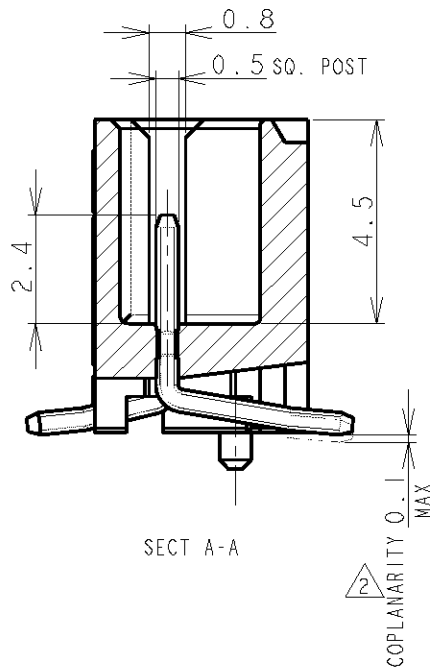
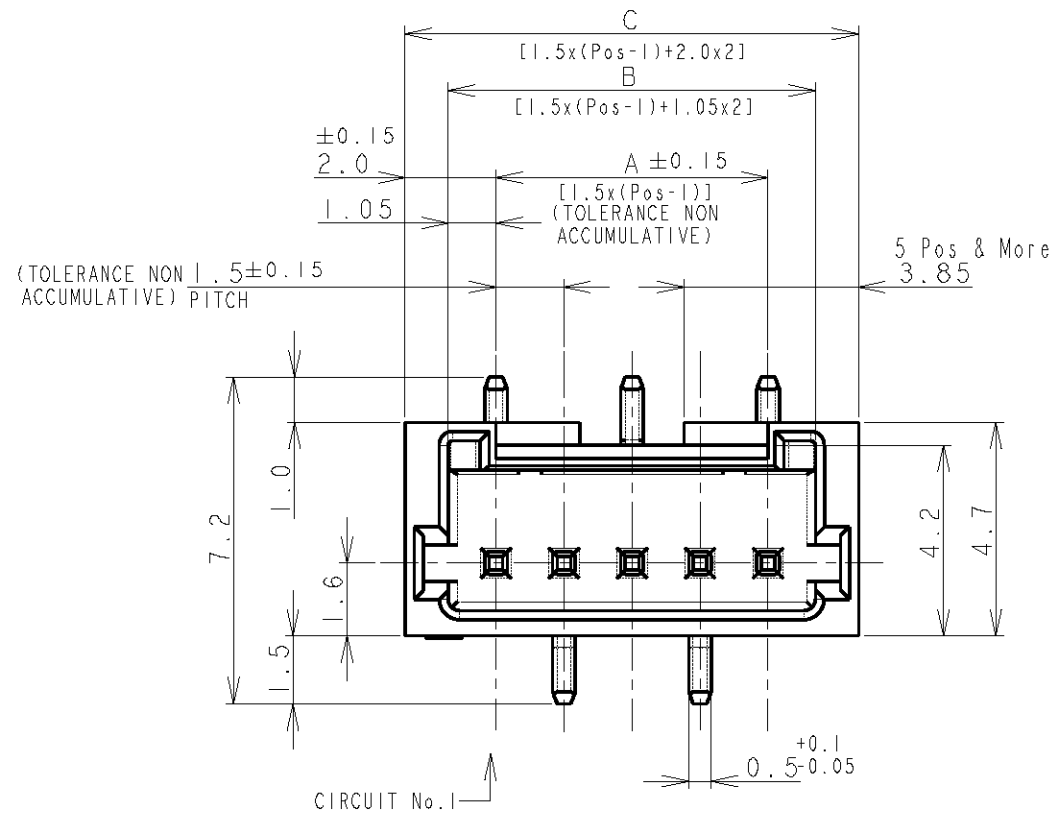

CIRCUIT No.1

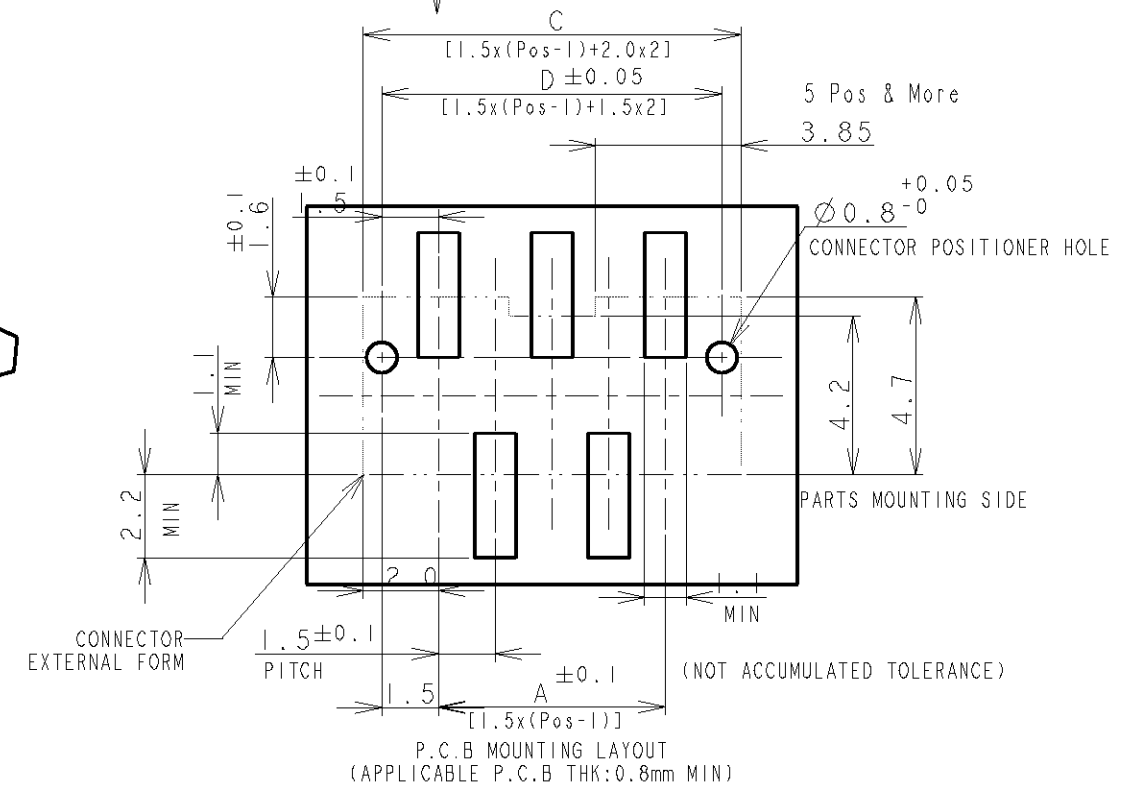
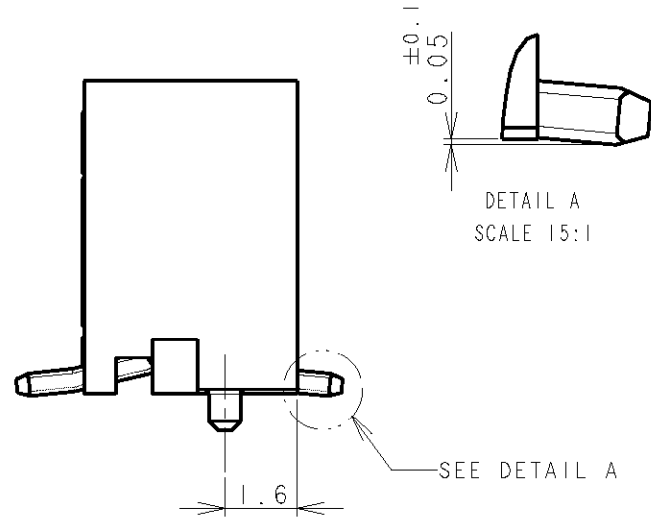
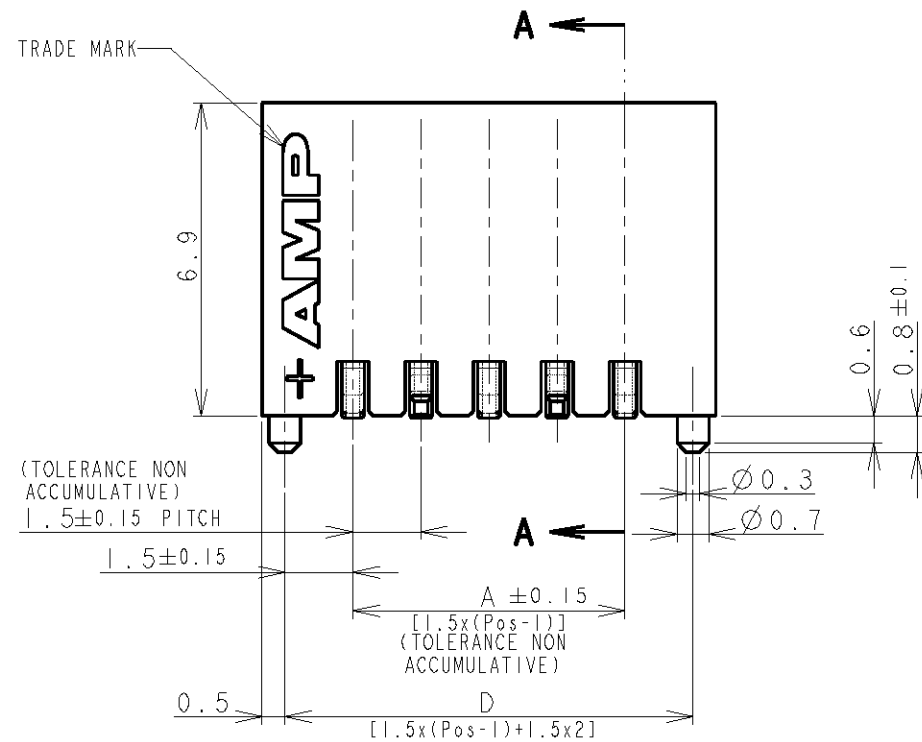

NOTES:
 1. MATERIAL:
 HOUSING: GLASS FILLED, HIGH HEAT RESISTANT NYLON, UL94V-0, COLOR: BEIGE OR BLACK
 POST: Sn-100% BRASS WIRE
 TO BE MEASURED WITH CONNECTOR PLACED ON HORIZONTAL DATUM SURFACE,
 FLOAT OF SOLDER TINE FROM DATUM SURFACE IS 0.1mm MAX.

DWN		STE TE Connectivity	
CHK			
APVD		NAME	
PRODUCT SPEC		AMP MINI COMMON TERMINATION (CT) CONNECTOR 1.5 mm PITCH	
APPLICATION SPEC		SINGLE ROW POST HDR ASS'Y (V) SMT TYPE WITH BOSS	
WEIGHT		SIZE	RESTRICTED TO
MATERIAL		CAGE CODE	
FINISH		DRAWING NO	
SEE NOTE 1		A3	
SEE NOTE 1		00779	
CUSTOMER DRAWING		C-292230	
SCALE		SHEET	REV
NON		3	B1

LOC	DIST	REVISIONS					
FB	00	P	LTR	DESCRIPTION	DATE	DWN	APVD
		-		SEE SHEET 1	-	-	-

0.98	31.5	32.5	30.6	28.5	20	7-292230-0	2-292230-0
0.93	30.0	31.0	29.1	27.0	19	6-292230-9	1-292230-9
0.89	28.5	29.5	27.6	25.5	18	6-292230-8	1-292230-8
0.84	27.0	28.0	26.1	24.0	17	6-292230-7	1-292230-7
0.80	25.5	26.5	24.6	22.5	16	6-292230-6	1-292230-6
0.75	24.0	25.0	23.1	21.0	15	6-292230-5	1-292230-5
0.71	22.5	23.5	21.6	19.5	14	6-292230-4	1-292230-4
0.66	21.0	22.0	20.1	18.0	13	6-292230-3	1-292230-3
0.62	19.5	20.5	18.6	16.5	12	6-292230-2	1-292230-2
0.57	18.0	19.0	17.1	15.0	11	6-292230-1	1-292230-1
0.52	16.5	17.5	15.6	13.5	10	6-292230-0	1-292230-0
0.48	15.0	16.0	14.1	12.0	9	5-292230-9	292230-9
0.43	13.5	14.5	12.6	10.5	8	5-292230-8	292230-8
0.39	12.0	13.0	11.1	9.0	7	5-292230-7	292230-7
0.34	10.5	11.5	9.6	7.5	6	5-292230-6	292230-6
0.30	9.0	10.0	8.1	6.0	5	5-292230-5	292230-5
0.25	7.5	8.5	6.6	4.5	4	5-292230-4	292230-4
0.20	6.0	7.0	5.1	3.0	3	5-292230-3	292230-3
0.17	4.5	5.5	3.6	1.5	2	-	-
WEIGHT (g)	D	C	B	A	Pos.	BLACK	BEIGE (NAT)
	DIMENSIONS					P/N	

THIS DRAWING IS UNPUBLISHED. ALL RIGHTS RESERVED. © COPYRIGHT BY

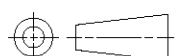
DIMENSIONS: mm		DWN	MATERIAL	FINISH		
TOLERANCES UNLESS OTHERWISE SPECIFIED:		CHK	SEE SHEET 1	SEE SHEET 1		
0 PLC ±	APVD	APVD	 TE Connectivity			
1 PLC ±		PRODUCT SPEC				
2 PLC ±		APPLICATION SPEC	NAME	AMP MINI COMMON TERMINATED (CT) CONNECTOR 1.5 mm PITCH		
3 PLC ±		WEIGHT	SINGLE ROW POST HDR ASS'Y (V) SMT TYPE WITH BOSS			
4 PLC ±			SIZE	CAGE CODE	DRAWING NO	
ANGLES ±			A4	00779	C-292230	
		CUSTOMER DRAWING		SCALE	SHEET 4 OF 4	
				NON	REV B1	