

**SECTION Z-Z - RETENTION PIN DETAIL**  
2 CONTACTS LOCATED ON CENTER OF SAME ROW  
(SEE NOTE 6)

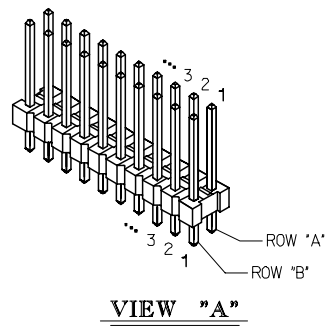
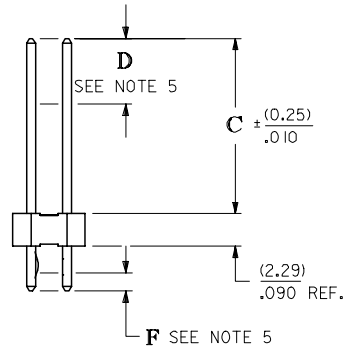
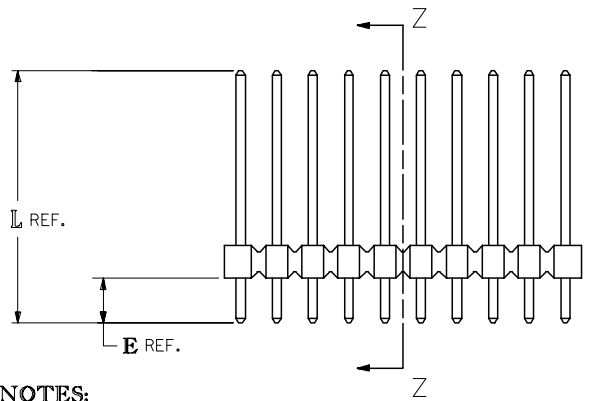

**VIEW "A"**

NO. OF CKTS.	DIM. A REF.		DIM. B REF.	
	MM	IN.	MM	IN.
4	4.83	.190	2.54	.100
6	7.37	.290	5.08	.200
8	9.91	.390	7.62	.300
10	12.45	.490	10.16	.400
12	14.99	.590	12.70	.500
14	17.53	.690	15.24	.600
16	20.07	.790	17.78	.700
18	22.61	.890	20.32	.800
20	25.15	.990	22.86	.900
22	27.69	1.090	25.40	1.000
24	30.23	1.190	27.94	1.100
26	32.77	1.290	30.48	1.200
28	35.31	1.390	33.02	1.300
30	37.85	1.490	35.56	1.400
32	40.39	1.590	38.10	1.500
34	42.93	1.690	40.64	1.600
36	45.47	1.790	43.18	1.700
38	48.01	1.890	45.72	1.800
40	50.55	1.990	48.26	1.900
42	53.09	2.090	50.80	2.000
44	55.63	2.190	53.34	2.100
46	58.17	2.290	55.88	2.200
48	60.71	2.390	58.42	2.300
50	63.25	2.490	60.96	2.400
52	65.79	2.590	63.50	2.500
54	68.33	2.690	66.04	2.600
56	70.87	2.790	68.58	2.700
58	73.41	2.890	71.12	2.800
60	75.95	2.990	73.66	2.900
62	78.49	3.090	76.20	3.000
64	81.03	3.190	78.74	3.100
66	83.57	3.290	81.28	3.200
68	86.11	3.390	83.82	3.300
70	88.65	3.490	86.36	3.400
72	91.19	3.590	88.90	3.500
74	93.73	3.690	91.44	3.600
76	96.27	3.790	93.98	3.700
78	98.81	3.890	96.52	3.800
80	101.35	3.990	99.06	3.900

**NOTES:**

- MATERIAL: WAFER - GLASS FILLED POLYESTER, UL94V-0, COLOR: BLACK  
PIN - PHOSPHOR BRONZE
- FINISH: (TIN)  
OVERALL TIN: (0.00381)/.000150 MIN.,  
OVERALL NICKEL UNDERPLATE: (0.00127)/.000050 MIN.,  
(15 GOLD) SELECT GOLD: (0.000381)/.000015 MIN.,  
SELECT TIN: (0.00191)/.000075 MIN.,  
OVERALL NICKEL UNDERPLATE: (0.00127)/.000050 MIN.,  
(30 GOLD) SELECT GOLD: (0.00076)/.000030 MIN.,  
SELECT TIN: (0.00191)/.000075 MIN.,  
OVERALL NICKEL UNDERPLATE: (0.00127)/.000050 MIN.
- \*THE PRIMARY SHIPPING CARTON WILL BE LABELED \*COMPLIANT TO  
RoHS DIRECTIVE 2002/95/EC AND ELV ANNEX II OF DIRECTIVE 2000/53/EC.\*  
CARTONS WITHOUT THIS LABEL MAY CONTAIN PRODUCT WITH LEAD.
- THIS PRODUCT CONFORMS TO PRODUCT SPECIFICATION PS-8624.
- PACKAGING INFORMATION: (UNLESS OTHERWISE NOTED IN TABLES)  
PARTS TO BE PACKAGED PER PK-70873-0353. BULK PACK WITH ANTISTATIC BAGS.
- MEASURE POINT FOR PLATING THICKNESS.
- RETENTIVE TAIL LOCATIONS (SEE VIEW "A")

NUMBER OF CIRCUITS IN ROW B	RETENTIVE TAIL LOCATIONS
EVEN NUMBER	2 PINS IN THE MIDDLE OF ROW B
ODD NUMBER	PIN IN THE CENTER OF ROW B AND ONE OTHER PIN IN ROW B ON EITHER SIDE OF THE CENTER PIN

- PIN PUSHOUT FORCE: 4 LBS. MIN. (IN EITHER DIRECTION)
- FOR ILLUSTRATION PURPOSES, 20 (DUAL 10) CIRCUIT SIZE IS SHOWN.
- PINS MUST MEET SOLDERABILITY SPEC. SMES-152, EXCEPT VOIDS ARE PERMISSIBLE AT BANDOLIER PIN FAYING SURFACE. (APPROXIMATELY (0.64)/.025 LNG X (0.15)/.006 WIDE REF.)
- WAFER TO BE FLAT WITHIN (0.003 MM/MM)/.003 IN./IN.
- FOR ASSEMBLIES WITH VOIDED PINS, SEE DRAWING NUMBER SDA-70287-5001-9999.
- PARTS CONFORM TO CLASS B REQUIREMENTS OF COSMETIC SPECIFICATION PS-45499-002.

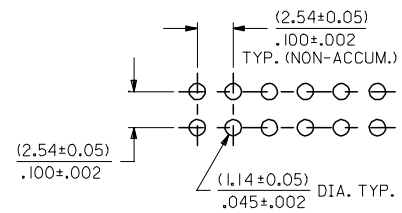

**RECOMMENDED P.C. BOARD HOLE LAYOUT**

2	H
1	H
SH.	REV.

UPDATE TITLE BLOCK EC NO: UCP2007-0511 DRAWN: ADERR 2006/12/24 CHKD: LSCHMIDT 2007/01/09 APPR: FSM TH 2007/01/10	QUALITY SYMBOLS ▽=0 ▽=0	GENERAL TOLERANCES (UNLESS SPECIFIED) mm INCH 4 PLACES ± --- ± --- 3 PLACES ± --- ± .005 2 PLACES ± 0.13 ± .01 1 PLACE ± 0.25 ± --- ANGULAR ±1/2°	DIMENSION STYLE MM/IN DRAWN BY DATE SMR 1993/06/02 CHECKED BY DATE SMR 1993/06/02 APPROVED BY DATE 1993/06/02	SCALE 4:1 DESIGN UNITS INCH THIRD ANGLE PROJECTION	TITLE SALES ASSEMBLY DUAL ROW .025 SQ. PINS/.100 GRID W/RETENTION PINS
		DRAFT WHERE APPLICABLE MUST REMAIN WITHIN DIMENSIONS	MATERIAL NO. SEE CHART	DOCUMENT NO. SDA-70287-0001-5000	SHEET NO. 1 OF 2

**molex** MOLEX INCORPORATED  
THIS DRAWING CONTAINS INFORMATION THAT IS PROPRIETARY TO MOLEX INCORPORATED AND SHOULD NOT BE USED WITHOUT WRITTEN PERMISSION

	13	12	11	10	9	8	7	6	5	4	3	2	1	
J	ENGINEERING NUMBER A-70287	RELEASE FOR MANUFACTURE	E REF.	L REF.	C ±(0.25) .010	RETENTIVE PIN LOCATION	PLATING TYPE SEE CODES LISTED ON SHEET 1	CONNECTOR END PLATING		P.C. BOARD END PLATING		FOR PACKAGING INFORMATION SEE NOTE 4, SHEET 1 UNLESS SPECIFIED BELOW		J
	-0002/-0040	R.F.M.	(3.18) .125	(11.56) .455	(6.10) .240	SEE NOTE 6, SHEET 1	TIN	TIN	(2.54) .100	TIN	(1.27) .050			
	-0042/-0080	R.F.M.	(3.18) .125	(13.59) .535	(8.13) .320	SEE NOTE 6, SHEET 1	TIN	TIN	(4.57) .180	TIN	(1.27) .050			
I	-0082/-0120	R.F.M.	(3.18) .125	(11.56) .455	(6.10) .240	SEE NOTE 6, SHEET 1	15 GOLD	GOLD	(2.54) .100	TIN	(1.27) .050			I
	-0122/-0160	R.F.M.	(3.18) .125	(13.59) .535	(8.13) .320	SEE NOTE 6, SHEET 1	15 GOLD	GOLD	(4.57) .180	TIN	(1.27) .050			
	-0162/-0200	R.F.M.	(3.18) .125	(11.56) .455	(6.10) .240	SEE NOTE 6, SHEET 1	30 GOLD	GOLD	(2.54) .100	TIN	(1.27) .050			
H	-0202/-0240	R.F.M.	(3.18) .125	(13.59) .535	(8.13) .320	SEE NOTE 6, SHEET 1	30 GOLD	GOLD	(4.57) .180	TIN	(1.27) .050			H
	-0242/-0280													

	CKTS	EDP NUMBER	ENG NUMBER	EDP NUMBER	ENG NUMBER	EDP NUMBER	ENG NUMBER	EDP NUMBER	ENG NUMBER	EDP NUMBER	ENG NUMBER	EDP NUMBER	ENG NUMBER	EDP NUMBER	ENG NUMBER	CKTS
	04	10-96-7043	A-70287-0002	10-96-7044	A-70287-0042	10-96-7045	A-70287-0082	10-96-7046	A-70287-0122	10-96-7047	A-70287-0162	10-96-7048	A-70287-0202		A-70287-0242	04
	06	10-96-7063	A-70287-0003	10-96-7064	A-70287-0043	10-96-7065	A-70287-0083	10-96-7066	A-70287-0123	10-96-7067	A-70287-0163	10-96-7068	A-70287-0203		A-70287-0243	06
	08	10-96-7083	A-70287-0004	10-96-7084	A-70287-0044	10-96-7085	A-70287-0084	10-96-7086	A-70287-0124	10-96-7087	A-70287-0164	10-96-7088	A-70287-0204		A-70287-0244	08
G	10	10-96-7103	A-70287-0005	10-96-7104	A-70287-0045	10-96-7105	A-70287-0085	10-96-7106	A-70287-0125	10-96-7107	A-70287-0165	10-96-7108	A-70287-0205		A-70287-0245	10
	12	10-96-7123	A-70287-0006	10-96-7124	A-70287-0046	10-96-7125	A-70287-0086	10-96-7126	A-70287-0126	10-96-7127	A-70287-0166	10-96-7128	A-70287-0206		A-70287-0246	12
	14	10-96-7143	A-70287-0007	10-96-7144	A-70287-0047	10-96-7145	A-70287-0087	10-96-7146	A-70287-0127	10-96-7147	A-70287-0167	10-96-7148	A-70287-0207		A-70287-0247	14
	16	10-96-7163	A-70287-0008	10-96-7164	A-70287-0048	10-96-7165	A-70287-0088	10-96-7166	A-70287-0128	10-96-7167	A-70287-0168	10-96-7168	A-70287-0208		A-70287-0248	16
	18	10-96-7183	A-70287-0009	10-96-7184	A-70287-0049	10-96-7185	A-70287-0089	10-96-7186	A-70287-0129	10-96-7187	A-70287-0169	10-96-7188	A-70287-0209		A-70287-0249	18
	20	10-96-7203	A-70287-0010	10-96-7204	A-70287-0050	10-96-7205	A-70287-0090	10-96-7206	A-70287-0130	10-96-7207	A-70287-0170	10-96-7208	A-70287-0210		A-70287-0250	20
	22	10-96-7223	A-70287-0011	10-96-7224	A-70287-0051	10-96-7225	A-70287-0091	10-96-7226	A-70287-0131	10-96-7227	A-70287-0171	10-96-7228	A-70287-0211		A-70287-0251	22
F	24	10-96-7243	A-70287-0012	10-96-7244	A-70287-0052	10-96-7245	A-70287-0092	10-96-7246	A-70287-0132	10-96-7247	A-70287-0172	10-96-7248	A-70287-0212		A-70287-0252	24
	26	10-96-7263	A-70287-0013	10-96-7264	A-70287-0053	10-96-7265	A-70287-0093	10-96-7266	A-70287-0133	10-96-7267	A-70287-0173	10-96-7268	A-70287-0213		A-70287-0253	26
	28	10-96-7283	A-70287-0014	10-96-7284	A-70287-0054	10-96-7285	A-70287-0094	10-96-7286	A-70287-0134	10-96-7287	A-70287-0174	10-96-7288	A-70287-0214		A-70287-0254	28
	30	10-96-7303	A-70287-0015	10-96-7304	A-70287-0055	10-96-7305	A-70287-0095	10-96-7306	A-70287-0135	10-96-7307	A-70287-0175	10-96-7308	A-70287-0215		A-70287-0255	30
	32	10-96-7323	A-70287-0016	10-96-7324	A-70287-0056	10-96-7325	A-70287-0096	10-96-7326	A-70287-0136	10-96-7327	A-70287-0176	10-96-7328	A-70287-0216		A-70287-0256	32
	34	10-96-7343	A-70287-0017	10-96-7344	A-70287-0057	10-96-7345	A-70287-0097	10-96-7346	A-70287-0137	10-96-7347	A-70287-0177	10-96-7348	A-70287-0217		A-70287-0257	34
	36	10-96-7363	A-70287-0018	10-96-7364	A-70287-0058	10-96-7365	A-70287-0098	10-96-7366	A-70287-0138	10-96-7367	A-70287-0178	10-96-7368	A-70287-0218		A-70287-0258	36
E	38	10-96-7383	A-70287-0019	10-96-7384	A-70287-0059	10-96-7385	A-70287-0099	10-96-7386	A-70287-0139	10-96-7387	A-70287-0179	10-96-7388	A-70287-0219		A-70287-0259	38
	40	10-96-7403	A-70287-0020	10-96-7404	A-70287-0060	10-96-7405	A-70287-0100	10-96-7406	A-70287-0140	10-96-7407	A-70287-0180	10-96-7408	A-70287-0220		A-70287-0260	40
	42	10-96-7423	A-70287-0021	10-96-7424	A-70287-0061	10-96-7425	A-70287-0101	10-96-7426	A-70287-0141	10-96-7427	A-70287-0181	10-96-7428	A-70287-0221		A-70287-0261	42
	44	10-96-7443	A-70287-0022	10-96-7444	A-70287-0062	10-96-7445	A-70287-0102	10-96-7446	A-70287-0142	10-96-7447	A-70287-0182	10-96-7448	A-70287-0222		A-70287-0262	44
	46	10-96-7463	A-70287-0023	10-96-7464	A-70287-0063	10-96-7465	A-70287-0103	10-96-7466	A-70287-0143	10-96-7467	A-70287-0183	10-96-7468	A-70287-0223		A-70287-0263	46
	48	10-96-7483	A-70287-0024	10-96-7484	A-70287-0064	10-96-7485	A-70287-0104	10-96-7486	A-70287-0144	10-96-7487	A-70287-0184	10-96-7488	A-70287-0224		A-70287-0264	48
	50	10-96-7503	A-70287-0025	10-96-7504	A-70287-0065	10-96-7505	A-70287-0105	10-96-7506	A-70287-0145	10-96-7507	A-70287-0185	10-96-7508	A-70287-0225		A-70287-0265	50
	52	10-96-7523	A-70287-0026	10-96-7524	A-70287-0066	10-96-7525	A-70287-0106	10-96-7526	A-70287-0146	10-96-7527	A-70287-0186	10-96-7528	A-70287-0226		A-70287-0266	52
D	54	10-96-7543	A-70287-0027	10-96-7544	A-70287-0067	10-96-7545	A-70287-0107	10-96-7546	A-70287-0147	10-96-7547	A-70287-0187	10-96-7548	A-70287-0227		A-70287-0267	54
	56	10-96-7563	A-70287-0028	10-96-7564	A-70287-0068	10-96-7565	A-70287-0108	10-96-7566	A-70287-0148	10-96-7567	A-70287-0188	10-96-7568	A-70287-0228		A-70287-0268	56
	58	10-96-7583	A-70287-0029	10-96-7584	A-70287-0069	10-96-7585	A-70287-0109	10-96-7586	A-70287-0149	10-96-7587	A-70287-0189	10-96-7588	A-70287-0229		A-70287-0269	58
	60	10-96-7603	A-70287-0030	10-96-7604	A-70287-0070	10-96-7605	A-70287-0110	10-96-7606	A-70287-0150	10-96-7607	A-70287-0190	10-96-7608	A-70287-0230		A-70287-0270	60
	62	10-96-7623	A-70287-0031	10-96-7624	A-70287-0071	10-96-7625	A-70287-0111	10-96-7626	A-70287-0151	10-96-7627	A-70287-0191	10-96-7628	A-70287-0231		A-70287-0271	62
	64	10-96-7643	A-70287-0032	10-96-7644	A-70287-0072	10-96-7645	A-70287-0112	10-96-7646	A-70287-0152	10-96-7647	A-70287-0192	10-96-7648	A-70287-0232		A-70287-0272	64
	66	10-96-7663	A-70287-0033	10-96-7664	A-70287-0073	10-96-7665	A-70287-0113	10-96-7666	A-70287-0153	10-96-7667	A-70287-0193	10-96-7668	A-70287-0233		A-70287-0273	66
	68	10-96-7683	A-70287-0034	10-96-7684	A-70287-0074	10-96-7685	A-70287-0114	10-96-7686	A-70287-0154	10-96-7687	A-70287-0194	10-96-7688	A-70287-0234		A-70287-0274	68
C	70	10-96-7703	A-70287-0035	10-96-7704	A-70287-0075	10-96-7705	A-70287-0115	10-96-7706	A-70287-0155	10-96-7707	A-70287-0195	10-96-7708	A-70287-0235		A-70287-0275	70
	72	10-96-7723	A-70287-0036	10-96-7724	A-70287-0076	10-96-7725	A-70287-0116	10-96-7726	A-70287-0156	10-96-7727	A-70287-0196	10-96-7728	A-70287-0236		A-70287-0276	72
	74	10-96-7743	A-70287-0037	10-96-7744	A-70287-0077	10-96-7745	A-70287-0117	10-96-7746	A-70287-0157	10-96-7747	A-70287-0197	10-96-7748	A-70287-0237		A-70287-0277	74
	76	10-96-7763	A-70287-0038	10-96-7764	A-70287-0078	10-96-7765	A-70287-0118	10-96-7766	A-70287-0158	10-96-7767	A-70287-0198	10-96-7768	A-70287-0238		A-70287-0278	76
	78	10-96-7783	A-70287-0039	10-96-7784	A-70287-0079	10-96-7785	A-70287-0119	10-96-7786	A-70287-0159	10-96-7787	A-70287-0199	10-96-7788	A-70287-0239		A-70287-0279	78
	80	10-96-7803	A-70287-0040	10-96-7804	A-70287-0080	10-96-7805	A-70287-0120	10-96-7806	A-70287-0160	10-96-7807	A-70287-0200	10-96-7808	A-70287-0240		A-70287-0280	80

B	UPDATE TITLE BLOCK EC NO: UCP2007-0511 DRAWN: AADER 2006/12/27 CHKD: LSHMI DT 2007/01/09 APPR: ESM TH 2007/01/10	DESCRIPTION REVISIONS 1 2	QUALITY SYMBOLS	GENERAL TOLERANCES (UNLESS SPECIFIED)	DIMENSION STYLE	SCALE	DESIGN UNITS	THIRD ANGLE PROJECTION
			IN/MM 4 PLACES ± --- ± --- 3 PLACES ± --- ± .005 2 PLACES ± 0.13 ± .01 1 PLACE ± 0.25 ± --- ANGULAR ±1/2°	DRAWN BY DATE SMR 1993/06/02 CHECKED BY DATE SMR 1993/06/02 APPROVED BY DATE SMR 1993/06/02	MATERIAL NO. SEE CHART SIZE C	TITLE SALES ASSEMBLY DUAL ROW .025 SQ PINS/100 GRID W/RETENTION PINS MOLEX MOLEX INCORPORATED	SHEET NO. 2 OF 2	
A	THIS DRAWING CONTAINS INFORMATION THAT IS PROPRIETARY TO MOLEX INCORPORATED AND SHOULD NOT BE USED WITHOUT WRITTEN PERMISSION							