

1

2

3

4

5

6

7

A

B

C

D

E

F

A

B

C

D

E

F

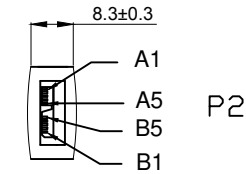
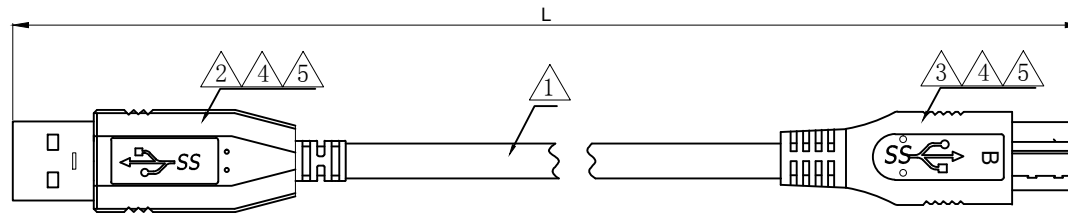
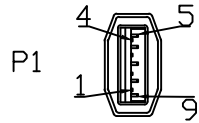

Printing: ㊦ AWM STYLE 2725 80°C 30V  
 VW-1 SUPER HIGH SPEED USB Revision 3.0

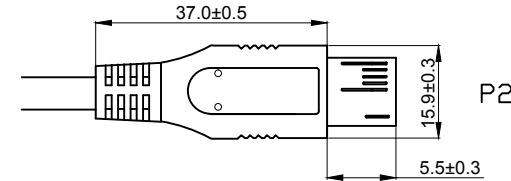
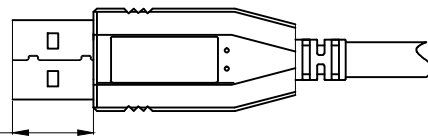

① Pin Assignment

P1	P2
1 — Red	B1
2 — White	B2
3 — Green	B3
4 — Black	B5
5 — Blue	A5
6 — Yellow	A4
7 — Drain	A3
8 — Orange	A2
9 — Purple	A1
Shell — Braid	Shell

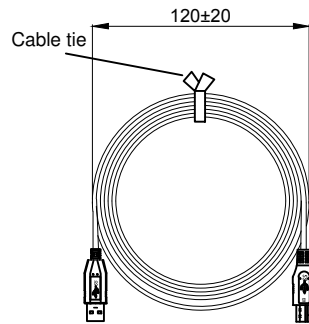

NOTES:

1. Cable Must Be Open, Short, Miswire 100% Test
2. Voltage: 300V DC
3. Contact Resistance: 5ohms max.
4. Insulation Resistance: 10M ohms min.
5. 1Pcs/PE Bag

WSW P/N	Length(mm)	Qty/Per Carton
A-USB30AM-30MBM-050	500±20	200
A-USB30AM-30MBM-100	1000±30	150
A-USB30AM-30MBM-200	2000±50	100
A-USB30AM-30MBM-300	3000±50	70
A-USB30AM-30MBM-500	5000±50	50

NO.	TITLE	DESCRIPTION
②	⑤ Inner Mold	LDPE WHITE
	④ Over Mold	PVC 45P Black
	③ CONN	USB3.0 Micro B/M, Black, PIN G/F, Shell Ni-Plated
	② CONN	USB3.0 A/M, Blue, PBT, PIN G/F, Shell Ni-Plated
	① CABLE	UL2725(Rev 3.0), OD:5.5mm BLACK, (1P#30+D+AL+Mylar)*2C+1P#30+2C#24+AL+B

RoHS compliant  
 Unit: mm

Scale	FREE					Date	Name	Customer-No.
TOLERANCE						Drawn	07.01.2019	Xavier
						Approved	12.02.2019	Winnie
		②	Packing quantities & PVC hardness	12.02.2019	Winnie			
DIM	TOL	①	Add wire color	07.15.2019	Xavier			
		①	Drawn	07.01.2019	Xavier			
Angle	TOL	Id.	Modification	Date	Name	Drawing-No. ASS 8454 CA rev02 Replace Sheet 1/1		

1

2

3

4

5

6

7