

**NOT RECOMMENDED FOR NEW DESIGNS**  
**RECOMMENDED REPLACEMENT PART**  
**ISL34341**

**WSVGA 24-Bit Long-Reach Video SERDES with Bidirectional Side-Channel**

The ISL34340 is a serializer/deserializer of LVCMOS parallel video data. The video data presented to the serializer on the parallel LVCMOS bus is serialized into a high-speed differential signal. This differential signal is converted back to parallel video at the remote end by the deserializer. It also transports auxiliary data bidirectionally over the same link during the video vertical retrace interval.

**Ordering Information**

PART NUMBER (Note)	PART MARKING	TEMP. RANGE (°C)	PACKAGE (Pb-free)	PKG. DWG. #
ISL34340INZ*	ISL34340INZ	-40 to +85	64 Ld EPTQFP	Q64.10x10B

\*Add "-T13" suffix for tape and reel. Please refer to TB347 for details on reel specifications.

NOTE: These Intersil Pb-free plastic packaged products employ special Pb-free material sets, molding compounds/die attach materials, and 100% matte tin plate plus anneal (e3 termination finish, which is RoHS compliant and compatible with both SnPb and Pb-free soldering operations). Intersil Pb-free products are MSL classified at Pb-free peak reflow temperatures that meet or exceed the Pb-free requirements of IPC/JEDEC J STD-020.

**Features**

- 24-bit RGB transport over single differential pair
- Bidirectional auxiliary data transport without extra bandwidth and over the same differential pair
- 40MHz PCLK transports
  - SVGA 800x600 @ 70fps, 16% blanking
  - WSVGA 1024x600 @ 60fps, 8% blanking
- Internal 100Ω termination on high-speed serial lines
- DC balanced 8b/10b line code allows AC-coupling
  - Provides immunity against ground shifts
- Transmitter amplitude boost and pre-emphasis and receiver equalization allow for longer cable lengths and higher data rates
- Same device for serializer and deserializer simplifies inventory
- I<sup>2</sup>C interface
- High-speed serial lines meet 8kV ESD rating
- Pb-free (RoHS compliant)

**Applications**

- Navigation and display systems
- Video entertainment systems
- Industrial computing terminals
- Remote cameras

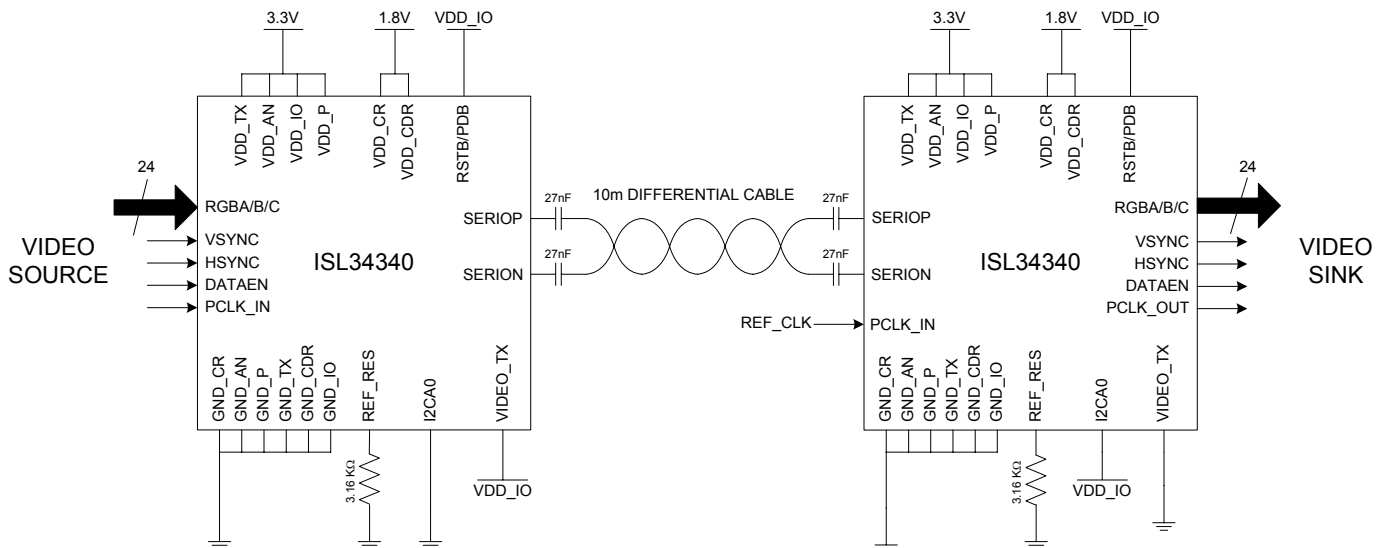

# ISL34340

## Pinout

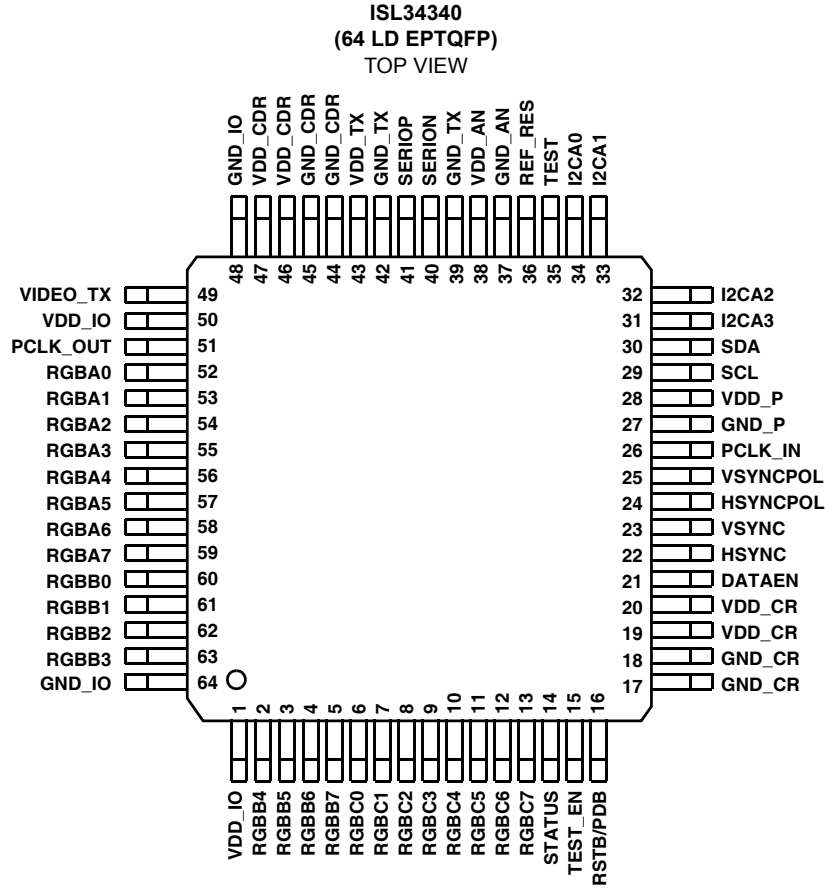

## Block Diagram

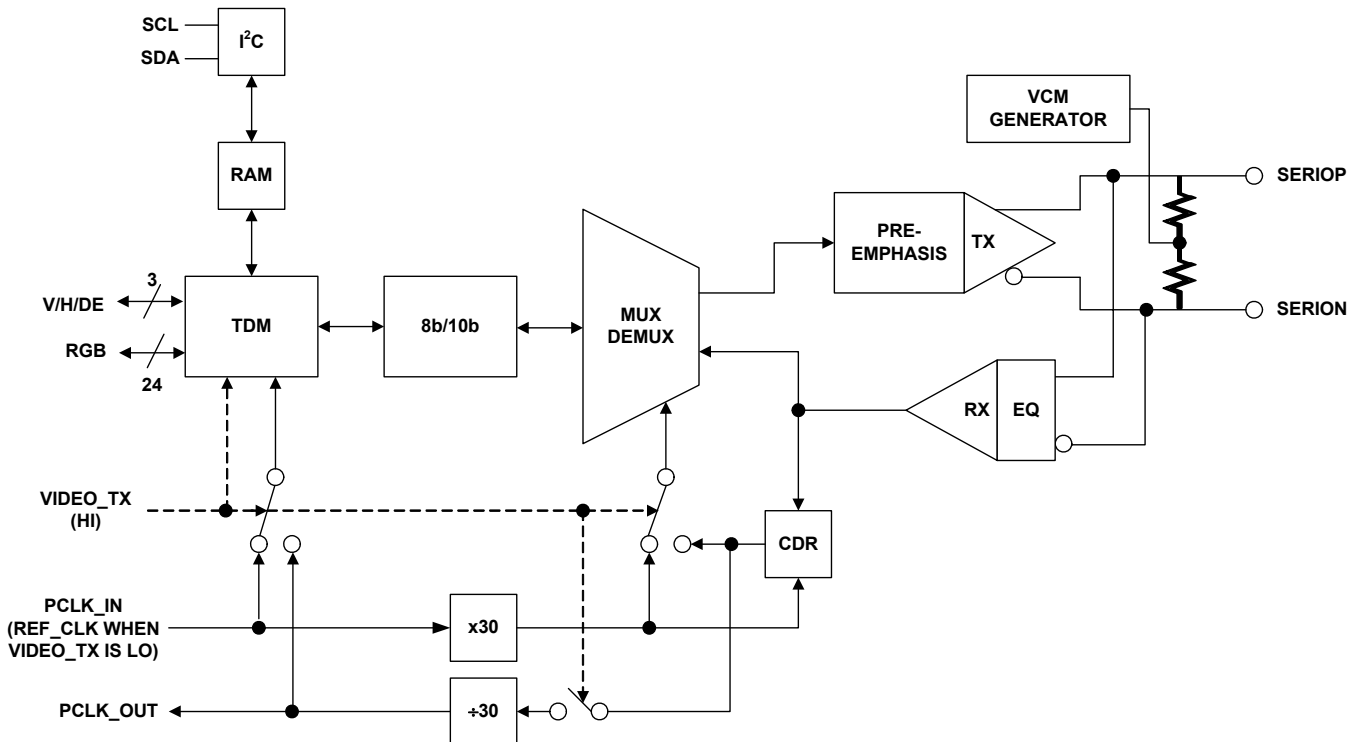

**Absolute Maximum Ratings**

Supply Voltage	
VDD_P to GND_P, VDD_TX to GND_TX, VDD_IO to GND_IO	-0.5V to 4.6V
VDD_CDR to GND_CDR, VDD_CR to GND_CR	-0.5V to 2.5V
Between any pair of GND_P, GND_TX, GND_IO, GND_CDR, GND_CR	-0.1V to 0.1V
3.3V Tolerant LVTTTL/LVCMOS Input Voltage	-0.3V to VDD_IO + 0.3V
Differential Input Voltage	-0.3V to VDD_IO + 0.3V
Differential Output Current	Short Circuit Protected
LVTTTL/LVCMOS Outputs	Short Circuit Protected
ESD Rating	
Human Body Model	
All pins	.4kV
SERIO/P/N (all VDD Connected, all GND Connected)	.8kV
Machine Model	.200V

**Thermal Information**

Thermal Resistance (Typical, Notes 1, 2)	$\theta_{JA}$	$\theta_{JC}$ (°C/W)
EPTQFP	33	4.5
Maximum Power Dissipation		327mW
Maximum Junction Temperature		+125°C
Maximum Storage Temperature Range		-65°C to +150°C
Operating Temperature Range		-40°C to +85°C
Pb-free reflow profile		see link below
	<a href="http://www.intersil.com/pbfree/Pb-FreeReflow.asp">http://www.intersil.com/pbfree/Pb-FreeReflow.asp</a>	

**CAUTION:** Do not operate at or near the maximum ratings listed for extended periods of time. Exposure to such conditions may adversely impact product reliability and result in failures not covered by warranty.

**NOTES:**

- $\theta_{JA}$  is measured in free air with the component mounted on a high effective thermal conductivity test board with "direct attach" features. See Tech Brief TB379.
- For  $\theta_{JC}$ , the "case temp" location is the center of the exposed metal pad on the package underside.

**Electrical Specifications** Unless otherwise indicated, all data is for: VDD\_CDR = VDD\_CR = 1.8V, VDD\_IO = 3.3V, VDD\_TX = VDD\_P = VDD\_AN = 3.3V, T<sub>A</sub> = +25°C, Ref\_Res = 3.16k $\Omega$ , High-speed AC-coupling capacitor = 27nF.

PARAMETER	SYMBOL	CONDITIONS	MIN	TYP	MAX	UNITS	
<b>POWER SUPPLY VOLTAGE</b>							
VDD_CDR, VDD_CR			1.7	1.8	1.9	V	
VDD_TX, VDD_P, VDD_AN, VDD_IO			3.0	3.3	3.6	V	
<b>SERIALIZER POWER SUPPLY CURRENTS</b>							
Analog TX Supply Current	I <sub>DDTX</sub>	VIDEO_TX = 1 PCLK_IN = 40MHz		17		mA	
Analog CDR Supply Current	I <sub>DDCDR</sub>			57		mA	
Digital I/O Supply Current	I <sub>DDIO</sub>			1	2	mA	
Digital Supply Current	I <sub>DDCR</sub>			20		mA	
PLL/VCO Supply Current	I <sub>DDP</sub>			17		mA	
Analog Bias Supply Current	I <sub>DDAN</sub>			5.5		mA	
Total 1.8V Supply Current					77	90	mA
Total 3.3V Supply Current					40	46	mA
<b>DESERIALIZER POWER SUPPLY CURRENTS</b>							
Analog TX Supply Current	I <sub>DDTX</sub>	VIDEO_TX = 0 REF_CLK = 40MHz		24		mA	
Analog CDR Supply Current	I <sub>DDCDR</sub>			45		mA	
Digital I/O Supply Current	I <sub>DDIO</sub>			17	25	mA	
Digital Supply Current	I <sub>DDCR</sub>			32		mA	
PLL/VCO Supply Current	I <sub>DDP</sub>			17		mA	
Analog Bias Supply Current	I <sub>DDAN</sub>			5.4		mA	
Total 1.8V Supply Current					77	90	mA
Total 3.3V Supply Current					64	80	mA

# ISL34340

**Electrical Specifications** Unless otherwise indicated, all data is for: VDD\_CDR = VDD\_CR = 1.8V, VDD\_IO = 3.3V, VDD\_TX = VDD\_P = VDD\_AN = 3.3V, T<sub>A</sub> = +25°C, Ref\_Res = 3.16kΩ, High-speed AC-coupling capacitor = 27nF. (Continued)

PARAMETER	SYMBOL	CONDITIONS	MIN	TYP	MAX	UNITS
<b>POWER-DOWN SUPPLY CURRENT</b>						
Total 1.8V Power-Down Supply Current		RSTB = GND; spec is per device		0.5		mA
Total 3.3V Power-Down Supply Current				1		mA
<b>PARALLEL INTERFACE</b>						
High Level Input Voltage	V <sub>IH</sub>		2.0			V
Low Level Input Voltage	V <sub>IL</sub>				0.8	V
Input Leakage Current	I <sub>IN</sub>		-10	±0.01	10	μA
High Level Output Voltage	V <sub>OH</sub>	I <sub>OH</sub> = -2.0mA, VDD_IO = 3V	0.8*VDD_IO			V
Low Level Output Voltage	V <sub>OL</sub>	I <sub>OL</sub> = 2.0mA, VDD_IO = 3V			0.2*VDD_IO	V
Output Short Circuit Current	I <sub>OSC</sub>				50	mA
Output Rise and Fall Times	t <sub>OR</sub> /t <sub>OF</sub>	Slew rate control set to min, C <sub>L</sub> = 8pF		1		ns
		Slew rate control set to max, C <sub>L</sub> = 8pF		4		ns
<b>SERIALIZER PARALLEL INTERFACE</b>						
PCLK_IN Frequency	f <sub>IN</sub>		6		40	MHz
PCLK_IN Duty Cycle	t <sub>IDC</sub>		40	50	60	%
Parallel Input Setup Time	t <sub>IS</sub>		3.6			ns
Parallel Input Hold Time	t <sub>IH</sub>		1.6			ns
<b>DESERIALIZER PARALLEL INTERFACE</b>						
PCLK_OUT Frequency	f <sub>OUT</sub>		6		40	MHz
PCLK_OUT Duty Cycle	t <sub>ODC</sub>			50		%
PCLK_OUT Period Jitter (RMS)	t <sub>OJ</sub>	Clock randomizer off		0.5		%t <sub>PCLK</sub>
PCLK_OUT Spread Width	t <sub>OSPRD</sub>	Clock randomizer on		±20		%t <sub>PCLK</sub>
Time to Parallel Output Data Valid	t <sub>DV</sub>	Relative to PCLK_OUT	-4.7		5.5	ns
Deserializer Output Latency	t <sub>CPD</sub>	Part-to-part, side-channel disabled	4	9	14	PCLK
<b>DESERIALIZER REFERENCE CLOCK (REF_CLK IS FED INTO PCLK_IN)</b>						
REF_CLK Lock Time	t <sub>PLL</sub>			100		μs
REF_CLK to PCLK_OUT Clock Maximum Frequency Offset		PCLK_OUT is the recovered clock	1500	5000		ppm
<b>HIGH-SPEED TRANSMITTER</b>						
HS Differential Output Voltage, Transition Bit	VOD <sub>TR</sub>	TXCN = 0x00	600	825	990	mV <sub>P-P</sub>
		TXCN = 0x0F		1170		mV <sub>P-P</sub>
		TXCN = 0xF0		975		mV <sub>P-P</sub>
		TXCN = 0xFF		1300		mV <sub>P-P</sub>
HS Differential Output Voltage, Non-Transition Bit	VOD <sub>NTR</sub>	TXCN = 0x00	600	825	990	mV <sub>P-P</sub>
		TXCN = 0x0F		460		mV <sub>P-P</sub>
		TXCN = 0xF0		975		mV <sub>P-P</sub>
		TXCN = 0xFF		600		mV <sub>P-P</sub>

# ISL34340

**Electrical Specifications** Unless otherwise indicated, all data is for: VDD\_CDR = VDD\_CR = 1.8V, VDD\_IO = 3.3V, VDD\_TX = VDD\_P = VDD\_AN = 3.3V, T<sub>A</sub> = +25°C, Ref\_Res = 3.16kΩ, High-speed AC-coupling capacitor = 27nF. **(Continued)**

PARAMETER	SYMBOL	CONDITIONS	MIN	TYP	MAX	UNITS
HS Generated Output Common Mode Voltage	V <sub>OCM</sub>			2.35		V
HS Common Mode Serializer-Deserializer Voltage Difference	ΔV <sub>CM</sub>			20	120	mV
HS Differential Output Impedance	R <sub>OUT</sub>		80	100	120	Ω
HS Output Latency	t <sub>LPD</sub>	Part-to-part	4	7	10	PCLK
HS Output Rise and Fall Times	t <sub>R</sub> /t <sub>F</sub>	20% to 80%		150		ps
HS Differential Skew	t <sub>SKEW</sub>			<10		ps
HS Output Random Jitter	t <sub>RJ</sub>			13.4		psRMS
HS Output Deterministic Jitter	t <sub>DJ</sub>			40		psP-P
<b>HIGH SPEED RECEIVER</b>						
HS Differential Input Voltage	V <sub>ID</sub>		150			mV <sub>P-P</sub>
HS Generated Input Common Mode Voltage	V <sub>ICM</sub>			2.32		V
HS Differential Input Impedance	R <sub>IN</sub>		80	100	120	Ω
HS Maximum Jitter Tolerance				0.52		UI <sub>P-P</sub>
<b>I<sup>2</sup>C</b>						
I <sup>2</sup> C Clock Rate (on SCL)	f <sub>I2C</sub>			100	400	kHz
I <sup>2</sup> C Clock Pulse Width (HI or LO)			1.3			μs
I <sup>2</sup> C Clock Low to Data Out Valid			0		1	μs
I <sup>2</sup> C Start/Stop Setup/Hold Time			0.6			μs
I <sup>2</sup> C Data in Setup Time			100			ns
I <sup>2</sup> C Data in Hold Time			100			ns
I <sup>2</sup> C Data out Hold Time			100			ms

## Pin Descriptions

PIN NUMBER	PIN NAME	DESCRIPTION	
		SERIALIZER	DESERIALIZER
52 to 63, 2 to 13	RGBA[7:0], RGG[7:0], RGBC[7:0]	Parallel video data LVCMOS inputs	Parallel video data LVCMOS outputs
22	HSYNC	Horizontal (line) Sync LVCMOS input	Horizontal (line) Sync LVCMOS output
23	VSYNC	Vertical (frame) Sync LVCMOS input	Vertical (frame) Sync LVCMOS output
21	DATAEN	Video Data Enable LVCMOS input	Video Data Enable LVCMOS output
26	PCLK_IN	Pixel clock LVCMOS input	PLL reference clock LVCMOS input
51	PCLK_OUT	Default; not used	Recovered clock LVCMOS output
41, 40	SERIO <sub>P</sub> , SERIO <sub>N</sub>	High speed differential serial I/O	High speed differential serial I/O
24	HSYNCPOL	CMOS input for HSYNC 1: HSYNC is active low 0: HSYNC is active high	
25	VSYNCPOL	CMOS input for VSYNC 1: VSYNC is active low 0: VSYNC is active high	

**Pin Descriptions** (Continued)

PIN NUMBER	PIN NAME	DESCRIPTION	
		SERIALIZER	DESERIALIZER
49	VIDEO_TX	CMOS input for video flow direction 1: video serializer 0: video deserializer	
29, 30	SDA, SCL	I <sup>2</sup> C Interface Pins (I <sup>2</sup> C DATA, I <sup>2</sup> C CLK)	
31 to 34	I2CA[3:0]	I <sup>2</sup> C Device Address	
16	RSTB/PDB	CMOS input for Reset and Power-down. For normal operation, this pin must be forced high. When this pin is forced low, the device will be reset. If this pin stays low, the device will be in PD mode.	
14	STATUS	CMOS output for Receiver Status: 1: Valid 8b/10b data received 0: otherwise Note: serializer and deserializer switch roles during side-channel reverse traffic	
36	REF_RES	Analog bias setting resistor connection; use 3.16kΩ ±1% to ground	
27	GND_P	PLL Ground	
48, 64	GND_IO	Digital (Parallel and Control) Ground	
44, 45	GND_CDR	Analog (Serial) Data Recovery Ground	
39, 42	GND_TX	Analog (Serial) Output Ground	
37	GND_AN	Analog Bias Ground	
17, 18	GND_CR	Core Logic Ground	
19, 20	VDD_CR	Core Logic VDD	
43	VDD_TX	Analog (Serial) Output VDD	
38	VDD_AN	Analog Bias VDD	
46, 47	VDD_CDR	Analog (Serial) Data Recovery VDD	
1, 50	VDD_IO	Digital (Parallel and Control) VDD	
28	VDD_P	PLL VDD	
15, 35	TEST_EN, TEST	Must be connected to ground	
Exposed Pad	Exposed Pad	Must be connected to ground	

## NOTES:

- Pins with the same name are internally connected together. However, this connection must NOT be used for connecting together external components or features.
- The various differently-named Ground pins are internally weakly connected. They must be tied together externally. The different names are provided to assist in minimizing the current loops involved in bypassing the associated supply VDD pins. In particular, for ESD testing, they should be considered a common connection.

Diagrams

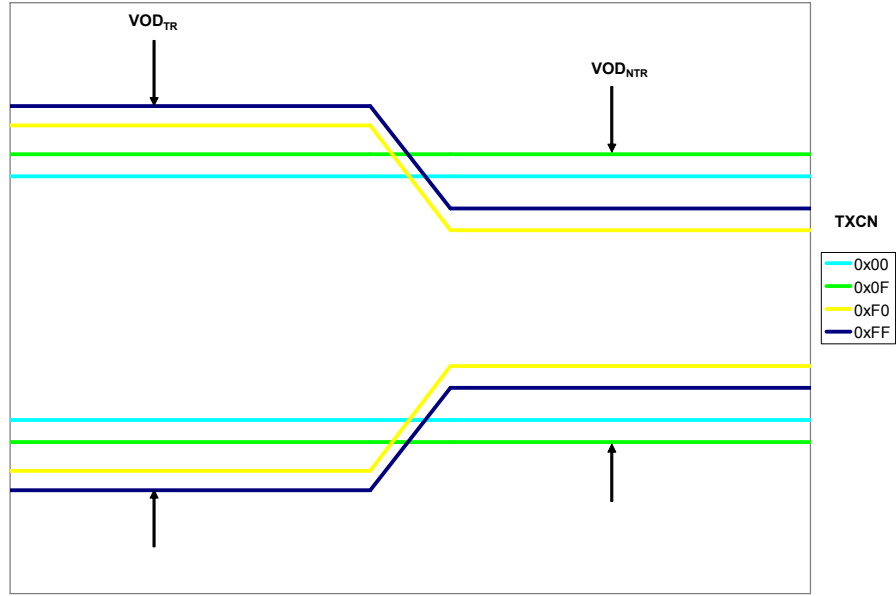

FIGURE 1. VOD vs TXCN SETTING

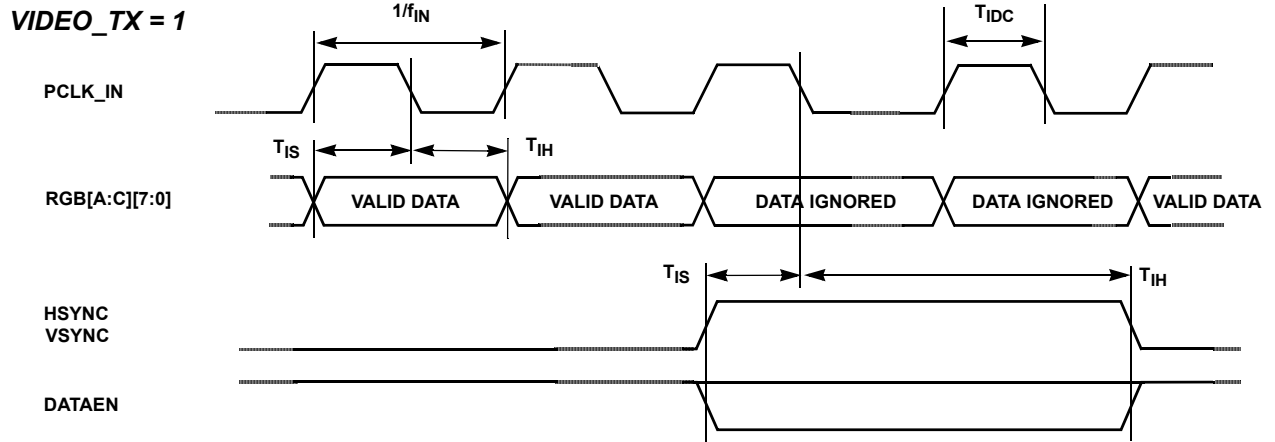

FIGURE 2. PARALLEL VIDEO INPUT TIMING [HSYNCPOL = 0, VSYNCPOL = 0, PCLKPOL (reg) = 0]

VIDEO\_TX = 0

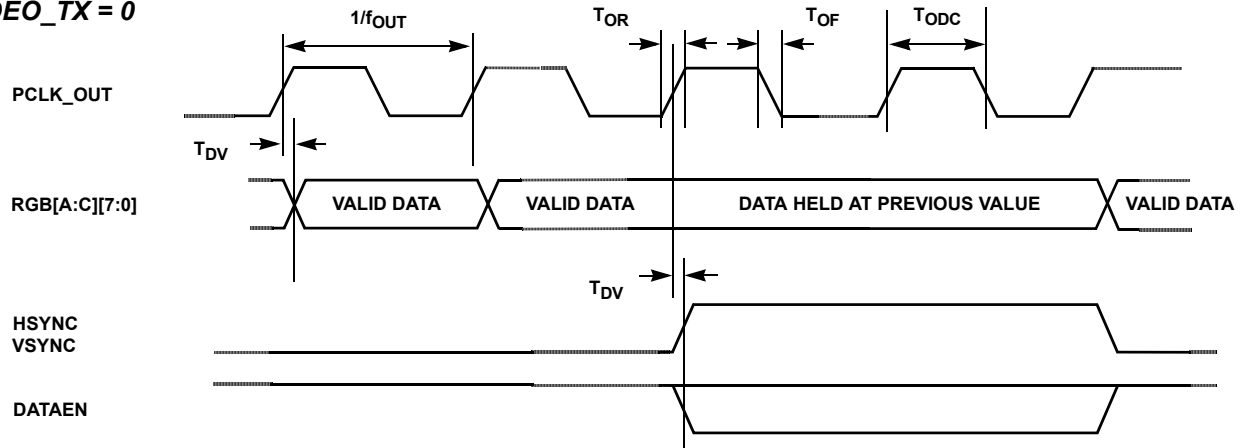

FIGURE 3. PARALLEL VIDEO OUTPUT TIMING [HSYNCPOL = 0, VSYNCPOL = 0, PCLKPOL (reg) = 0]

## Applications

### Overview

A pair of ISL34340 SERDES transports 24-bit parallel video (16-bit parallel video for the ISL34320) along with auxiliary data over a single 100Ω differential cable either to a display or from a camera. Auxiliary data is transferred in both directions and can be used for remote configuration and telemetry.

The benefits include lower EMI, lower costs, greater reliability and space savings. The same device can be configured to be either a serializer or deserializer by setting one pin (VIDEO\_TX), simplifying inventory. RGBA/B/C, VSYNC, HSYNC, and DATAEN pins are inputs in serializer mode and outputs in deserializer mode.

The video data presented to the serializer on the parallel LVCMOS bus is serialized into a high-speed differential signal. This differential signal is converted back to parallel video at the remote end by the deserializer. The side-channel data is transferred between the SERDES pair during two lines of the vertical video blanking interval.

When the side-channel is enabled, there will be a number of PCLK cycles uncertainty from frame-to-frame. This should not cause sync problems with most displays, as this occurs during the vertical front porch of the blanking period. When properly configured, the SERDES link supports end-to-end transport with fewer than one error in  $10^{10}$  bits.

### Differential Signals and Termination

The ISL34340 serializes the 24-bit parallel data at 30x the PCLK\_IN frequency. The ISL34320 serializes the 16-bit parallel data at 20x the PCLK\_IN frequency. The extra 2 bits per word come from the 8b/10b encoding scheme.

The high bit rate of the differential serial data requires special care in the layout of traces on PCBs, in the choice and assembly of connectors, and in the cables themselves.

PCB traces need to be adjacent and matched in length (so as to minimize the imbalanced coupling to other traces or elements), and of a geometry to match the impedance of the transmitter and receiver, to minimize reflections. Similar care needs to be applied to the choice of connectors and cables.

SERIO and SERION pins incorporate internal differential termination of the serial signal lines. External termination cannot be used unless the side-channel is disabled.

### SERIO Pin AC-Coupling

AC-coupling minimizes the effects of DC common mode voltage difference and local power supply variations between two SERDES. The serializer outputs DC balanced 8b/10b line code, which allows AC-coupling.

The AC-coupling capacitor on SERIO pins must be 27nF on the serializer board and 27nF on the deserializer board. The value of the AC-coupling capacitor is very critical since a value too small will attenuate the high speed signal at low clock rate. A value too big will slow down the turn around time for the side-channel.

### Receiver Reference Clock (REF\_CLK)

The reference clock (REF\_CLK) for the PLL is fed into PCLK\_IN pin. REF\_CLK is used to recover the clock from the high speed serial stream. REF\_CLK is very sensitive to any instability. The following conditions must be met at all times after power is applied to the deserializer, or else the deserializer may need a manual reset:

- REF\_CLK frequency must be within the limits specified
- REF\_CLK amplitude must be stable.

A simple 3.3V CMOS crystal oscillator can be used for REF\_CLK.

### Power Supply Sequencing

The 3.3V supply must be higher than the 1.8V supply at all times, including during power-up and power-down. To meet



this requirement, the 3.3V supply must be powered up before the 1.8V supply.

For the deserializer, REF\_CLK must not be applied before the device is fully powered up. Applying REF\_CLK before power-up may require the deserializer to be manually reset. A 10ms delay after the 1.8V supply is powered up guarantees normal operation.

**Power Supply Bypassing**

The serializer and deserializer functions rely on the stable functioning of PLLs locked to local reference sources or locked to an incoming signal. It is important that the various supplies (VDD\_P, VDD\_AN, VDD\_CDR, VDD\_TX) be well bypassed over a wide range of frequencies, from below the typical loop bandwidth of the PLL to approaching the signal bit rate of the serial data. A combination of different values of capacitors from 1000pF to 5µF or more with low ESR characteristics is generally required.

The parallel LVCMOS VDD\_IO supply is inherently less sensitive, but since the RGB and SYNC/DATAEN signals can all swing on the same clock edge, the current in these pins and the corresponding GND pins can undergo substantial current flow changes, so once again, a combination of different values of capacitors over a wide range, with low ESR characteristics, is desirable.

A set of arrangements of this type is shown in Figure 4, where each supply is bypassed with a ferrite-bead-based choke, and a range of capacitors. A “choke” is preferable to an “inductor” in this application, since a high-Q inductor will be likely to cause one or more resonances with the shunt capacitors, potentially causing problems at or near those frequencies, while a “lossy” choke will reflect a high impedance over a wide frequency range.

The higher value capacitor, in particular, needs to be chosen carefully, with special care regarding its ESR. Very good results can be obtained with multilayer ceramic capacitors, available from many suppliers, and generally in small outlines (such as the 1210 outline suggested in the schematic shown in Figure 4), which provide good bypass capabilities down to a few mΩ at 1MHz to 2MHz. Other capacitor technologies may also be suitable (perhaps niobium oxide), but “classic” electrolytic capacitors frequently have ESR values of above 1Ω, that nullify any decoupling effect above the 1kHz to 10kHz frequency range.

Capacitors of 0.1µF offer low impedance in the 10MHz to 20MHz region, and 1000pF capacitors in the 100MHz to 200MHz region. In general, one of the lower value capacitors should be used at each supply pin on the IC. Figure 4 shows the grounding of the various capacitors to the pin corresponding to the supply pin. Although all the ground supplies are tied together, the PCB layout should be arranged to emulate this arrangement, at least for the smaller value (high frequency) capacitors, as much as possible.

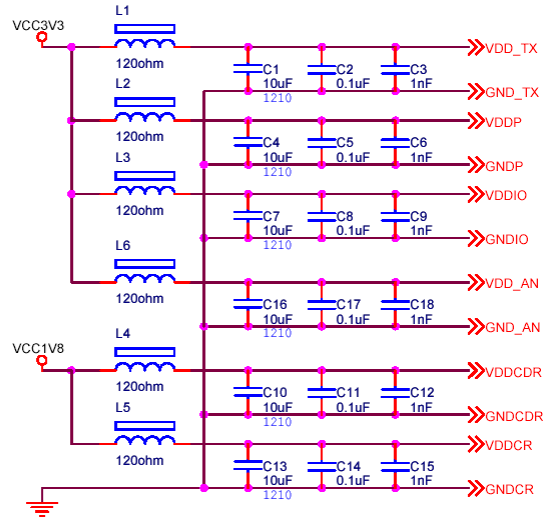

FIGURE 4. POWER SUPPLY BYPASSING

**I<sup>2</sup>C Interface**

The I<sup>2</sup>C interface allows access to internal registers used to configure the SERDES and to obtain status information. A serializer must be assigned a different address than its deserializer counterpart. The upper 3 bits are permanently set to 011 and the lower 4 bits determined by pins as follows:

0	1	1	I2CA3	I2CA2	I2CA1	I2CA0	R/W
---	---	---	-------	-------	-------	-------	-----

Thus, 16 SERDES can reside on the same bus. By convention, when all address pins are tied low, the device address is referred to as 0x60.

SCL and SDA are open drain to allow multiple devices to share the bus. If not used, SCL and SDA should be tied to VDD\_IO.

All Intersil U.S. products are manufactured, assembled and tested utilizing ISO9000 quality systems. Intersil Corporation’s quality certifications can be viewed at [www.intersil.com/design/quality](http://www.intersil.com/design/quality)

*Intersil products are sold by description only. Intersil Corporation reserves the right to make changes in circuit design, software and/or specifications at any time without notice. Accordingly, the reader is cautioned to verify that data sheets are current before placing orders. Information furnished by Intersil is believed to be accurate and reliable. However, no responsibility is assumed by Intersil or its subsidiaries for its use; nor for any infringements of patents or other rights of third parties which may result from its use. No license is granted by implication or otherwise under any patent or patent rights of Intersil or its subsidiaries.*

For information regarding Intersil Corporation and its products, see [www.intersil.com](http://www.intersil.com)

Thin Plastic Quad Flatpack Exposed Pad Plastic Packages (EPTQFP)

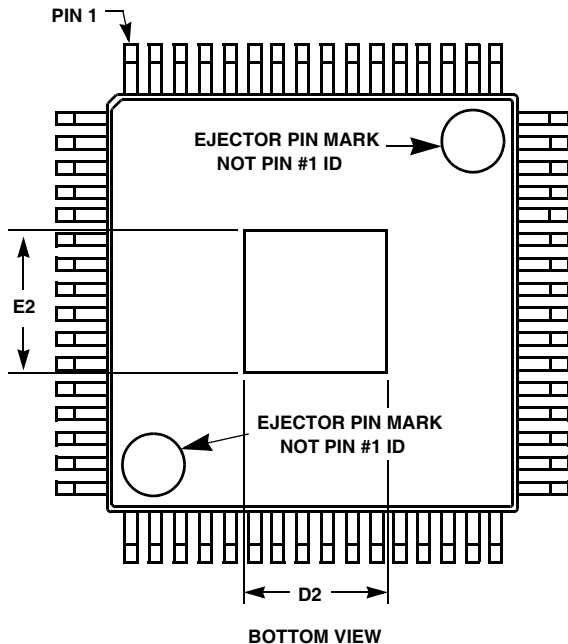
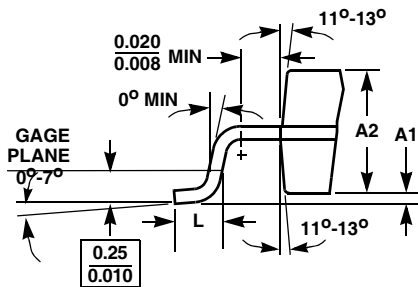
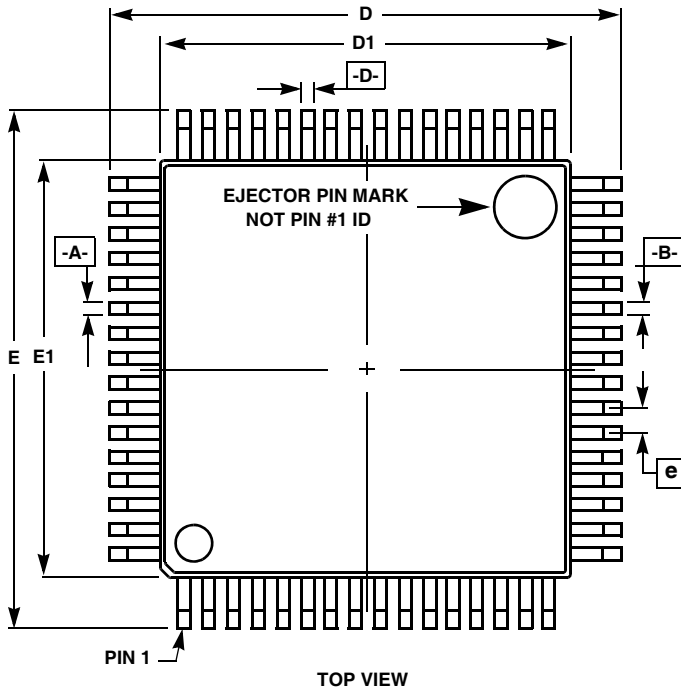

**Q64.10x10B** (JEDEC MS-026ACD-HU ISSUE D)  
64 LEAD THIN PLASTIC QUAD FLATPACK EXPOSED  
PAD PACKAGE

SYMBOL	MILLIMETERS		NOTES
	MIN	MAX	
A	-	1.20	-
A1	0.05	0.15	-
A2	0.95	1.05	-
b	0.16	0.28	6
b1	0.17	0.23	-
D	11.80	12.20	3
D1	9.90	10.10	4, 5
D2	3.46	3.76	-
E	11.80	12.20	3
E1	9.90	10.10	4, 5
E2	3.46	3.76	-
L	0.45	0.75	-
N	64		7
e	0.50 BSC		-

Rev. 2 4/08

NOTES:

- Controlling dimension: MILLIMETER. Converted inch dimensions are not necessarily exact.
- All dimensions and tolerances per ANSI Y14.5M-1982.
- Dimensions D and E to be determined at seating plane [-C-].
- Dimensions D1 and E1 to be determined at datum plane [-H-].
- Dimensions D1 and E1 do not include mold protrusion. Allowable protrusion is 0.25mm (0.010 inch) per side.
- Dimension b does not include dambar protrusion. Allowable dambar protrusion shall not cause the lead width to exceed the maximum b dimension by more than 0.08mm (0.003 inch).
- "N" is the number of terminal positions.

