

ITEM #	PART #	QTY	DESCRIPTION
1	TJ-101-10 OR TJ-101-100S	1	TELEPHONE JACK
2	TJ-101-3	1	SHELL
3	TJ-105-13	1	STRAIN RELIEF CLAMP

C TJ-101-CP

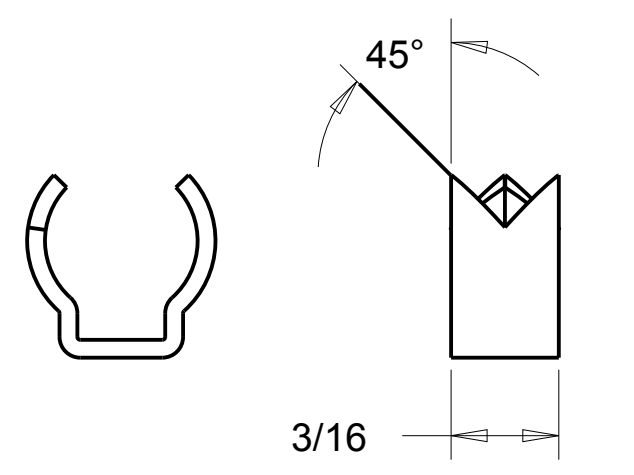
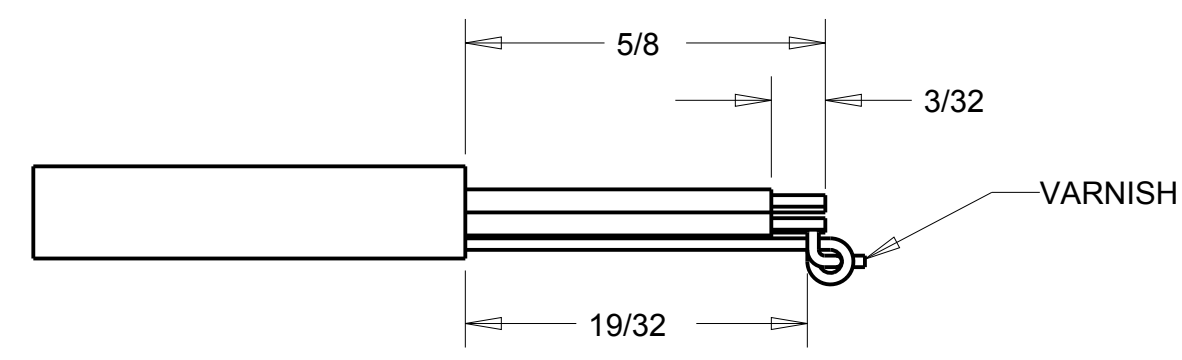
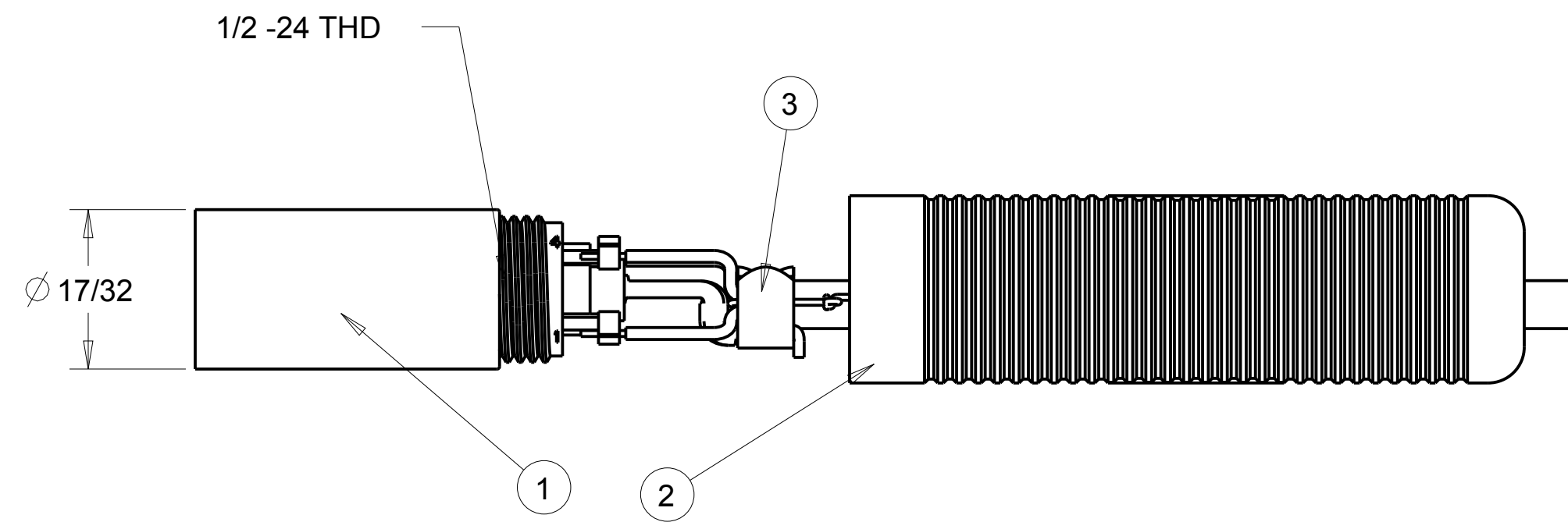
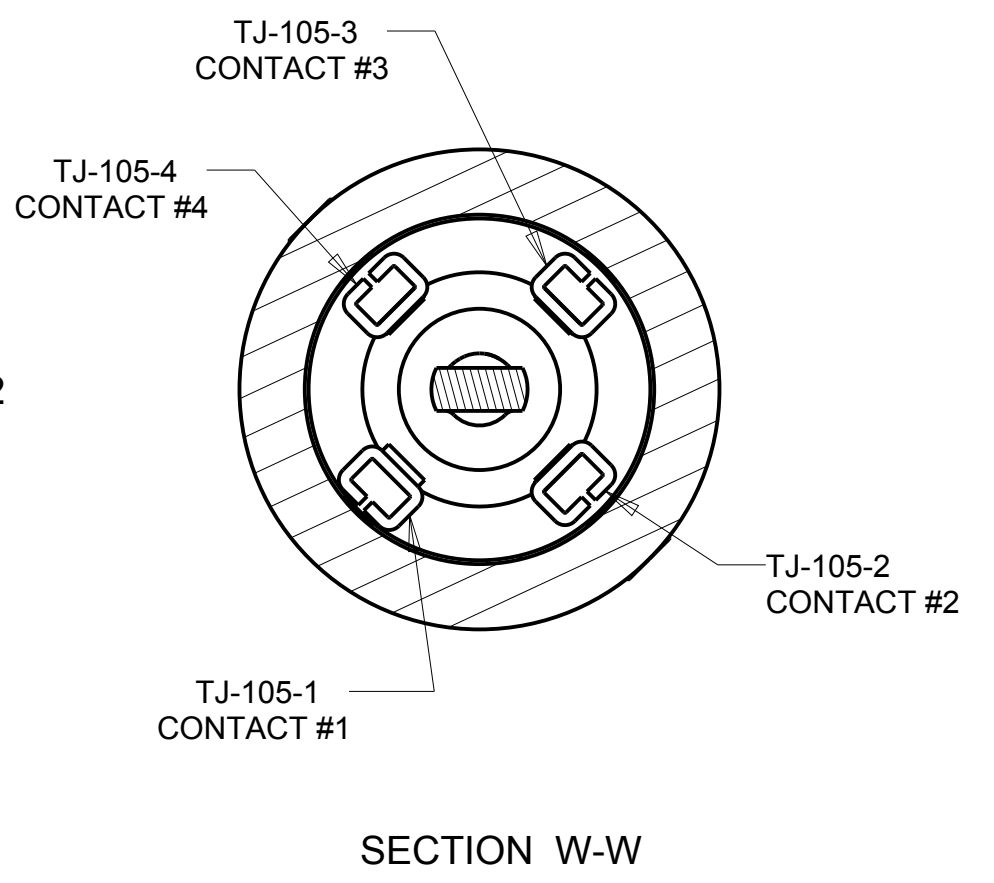
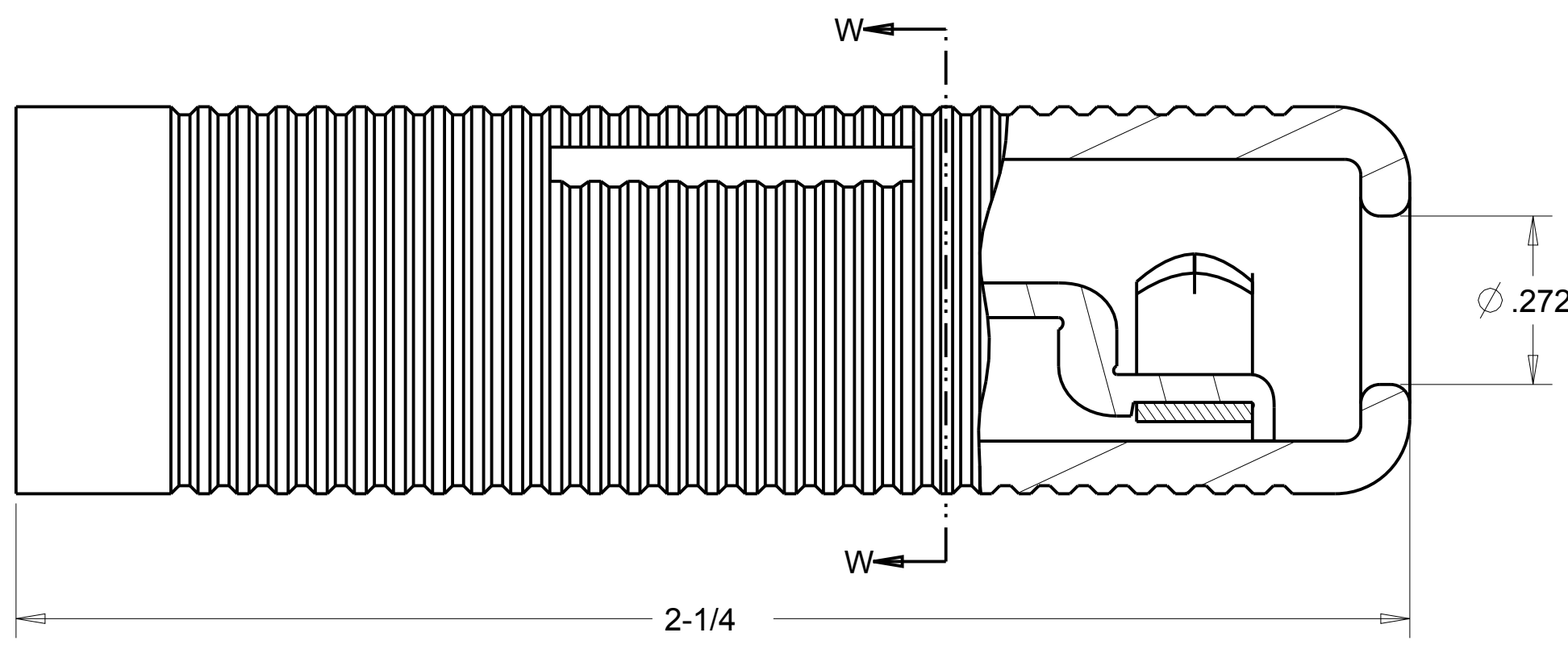
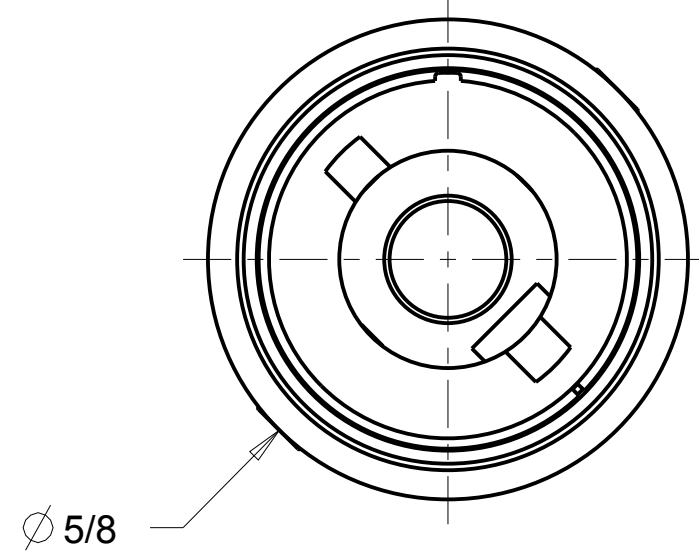

TJ-105-13 STRAIN RELIEF CLAMP FOR CABLE WITH $\phi .280$ MAX OD

- CONDENSED SPECIFICATIONS:
- THIS JACK MATES WITH NEXUS TELEPHONE PLUG TP-101 WITH A MAX INSERTION FORCE OF 10 LBS & WITHDRAWL FORCE OF 6 LBS MIN TO 10 LBS MAX
 - THE STRAIN RELIEF CLAMP IS INTENDED FOR USE WITH CABLES APPROX $\phi .275$ OUTSIDE DIA.
 - THE SOLDER TERMINALS EACH WILL ACCEPT TWO STRANDED CONDUCTORS OF 404 CIRCULAR MILS (24 GAGE, 41 STRANDS OF 40 AWG)
 - EACH CONDUCTOR IS OF ONE PIECE CONSTRUCTION. THERE ARE NO JOINTS OF ANY TYPE BETWEEN THE CONTACT AREA & THE SOLDER TERMINAL.
 - THE STAY CORD ANCHOR WILL WITHSTAND A 50 LB PULL FOR AT LEAST 5 MIN.
 - MATERIALS:
 - CONTACTS- BREYLLIUM COPPER PER FEDERAL SPEC QQ-C-533. FINISH NICKEL PLATER PER FEDERAL SPEC QQ-N-290, CLASS 2, TYPE 6.
 - BODY INSULATION
 - STRAIN RELIEF CLAMP; STAINLESS STEEL PER FEDERAL SPEC QQ-5-766, CLASS 4
 - SHELL: GLASS FILLED NYLON, BLACK
 - ELECTRICAL:
 - DIELECTRIC STRENGTH: 500 VOLTS RMS MIN BETWEEN ANY PAIR OF CONTACTS.
 - INSULATION RESISTANCE: 100 MEGAOHMS MIN BETWEEN ANY PAIR OF CONTACTS.
 - CONTACT RESISTANCE: WHEN MATED WITH NEXUS TP-101 TELEPHONE PLUG & WITH A DIRECT CURRENT OF 100 MILLIAMPERES AT 5 VOLTS (OPEN CIRCUIT VOLTAGE) FLOWING THROUGH THE CONTACTS, THE POTENTIAL DROP BETWEEN EACH PAIR OF CONTACTSWILL NOT EXCEED .005 VOLTS.

SUGGESTED LEAD DRESS

ORDER PART NUMBER TJ-101

THIS DOCUMENT CONTAINS PROPRIETARY INFORMATION OF NEXUS, INCORPORATED AND SUCH INFORMATION MAY NOT BE DISCLOSED TO OTHERS FOR ANY PURPOSE OR USED FOR ANY PURPOSE WITHOUT THE WRITTEN CONSENT OF NEXUS.

DWN BY IDH		DATE 10/22/87		MATERIAL	
CHECKED BY		DATE		FINISH	
APPR BY		DATE		WEIGHT	SCALE = 4.00 :1
UNLESS OTHERWISE SPECIFIED DIMENSIONS ARE IN INCHES & OR (mm)				TITLE	
TOLERANCES:				TELEPHONE JACK	
DECIMAL:				NEXUS STAMFORD, CONN	
±.XX(X.X) ±.XXX(X.XX) ±.XXXX(X.XXX)				SIZE	DWG. NO.
±.01(0.3) ±.003(0.08) ±.0005(0.013)				C	TJ-101-CP
FRACTION: ±X/XX ± 1/64				DO NOT SCALE DWG. SHEET 1 OF 1	
ANGLES: ±X ° ±5 °					