

Nuvoton
Advanced Power Control IC
NCT3012S

-TABLE OF CONTENTS-

1. GENERAL DESCRIPTION 1

2. FEATURES 2

3. BLOCK DIAGRAM 3

4. PIN CONFIGURATION 4

5. PIN DESCRIPTION..... 5

6. CONTROL AND STATUS REGISTER 7

 6.1 Deep Sleep Enable Control Register (DPSENCTRL) 7

 6.2 Deep S5 Delay Time Control (DELAYCTRL) 8

 6.3 Chip and Version ID Register (CVID) 8

7. ELECTRICAL CHARACTERISTIC 9

 7.1 ABSOLUTE MAXIMUM RATINGS 9

 7.2 DC CHARACTERISTICS..... 9

 7.3 AC CHARACTERISTICS 10

8. TYPICAL APPLICATION REFERENCE CIRCUIT 11

9. PACKAGE SPECIFICATIONS..... 12

10. ORDERING INFORMATION..... 13

11. TOP MARKING SPECIFICATIONS..... 13

12. REVISION HISTORY 14

1. GENERAL DESCRIPTION

The NCT3012S is Nuvoton's advanced power control IC which is specifically designed for desktop, notebook and any embedded system applications. The NCT3012S provides a mechanism to further lower the total system power consumption while the system is in S5 state. The NCT3012S could block the entire system standby power that comes from the ATX power supplier while the system is in S5 state, and it is fulfilled via the control of the external transistor. The NCT3012S is the only active IC under that circumstance so the total system power consumption is minimized. The system standby power could be resumed by the pushing of the external power button. The NCT3012S is powered by the 5VSB from the ATX power supplier, and communicates with the system through 2-wire System Management Bus (SMBus™) serial interface. The package is 8-pin ESOP green package.

2. FEATURES

2.1 General Description

- IC Communication Interface: I²C® Compatible System Management Bus (SMBus™) Serial Interface
- IC Operation Power Source: 5 Volt VSB Power from ATX Power Supply
- Supports ACPI (Advanced Configuration and Power Interface) Power Sequence
- Supports Programmable Configuration Settings
- Supports Deep S5 Power Saving Control

2.2 PACKAGE

- SOP-8 150mil with Exposed Pad Package
- Lead Free (ROHS Compliant) and Halogen Free SOP-8

2.3 APPLICATION

- Desktop and Notebook Computers
- Servers
- Embedded Applications

3. BLOCK DIAGRAM

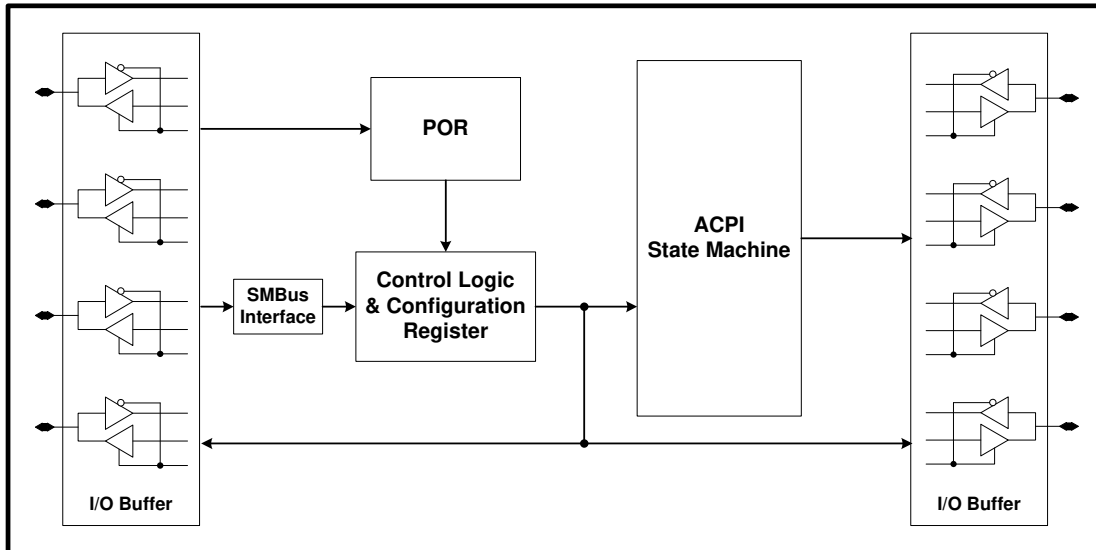

4. PIN CONFIGURATION

- NCT3012S PIN CONFIGURATION

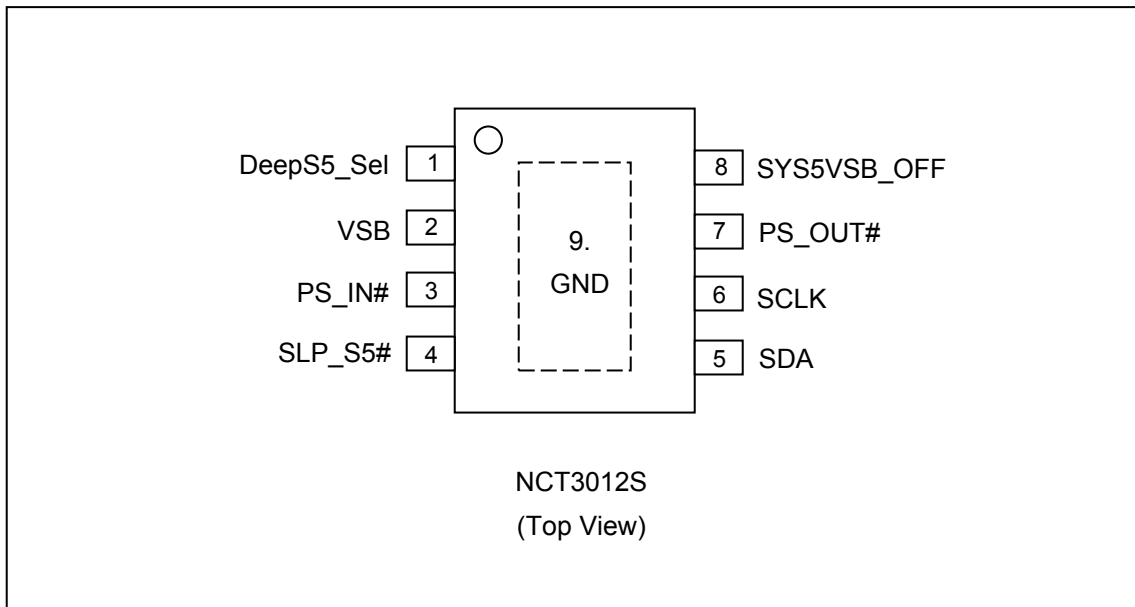

5. PIN DESCRIPTION

● PIN TYPE DESCRIPTION

PIN TYPE	PIN ATTRIBUTE
I/OD _{12TS}	TTL level and schmitt trigger open drain output with 12 mA sink capability
I/O _{12TS}	TTL level and schmitt trigger with 12 mA source and sink capability
I/OD ₁₂	Bi-directional pin and open-drain output with 12mA sink capability
OD ₁₂	Open-drain output pin with 12 mA sink capability
IN _{TS}	TTL level input pin and schmitt trigger
AIN	Input pin (Analog)
AOUT	Output pin (Analog)
IN	Input pin
OUT	Output pin
P	Power or Ground Pin

● NCT3012S PIN DESCRIPTION

PIN	SYMBOL	I/O	POWER WELL	FUNCTION
1	DeepS5_Sel	Strapping	VSB	Function Selection. Strapped by VSB ● Strapped to high : DeepS5_Sel = 1: System will enter the deep S5 state after 6 sec delays when AC power on. ● Strapped to low : (Default) DeepS5_Sel = 0: System will not enter the deep S5 state when AC power on. System is in normal ACPI S5 state.
2	VSB	P	VSB	5V stand-by power supply for the digital circuits.
3	PS_IN#	IN _{TS}	VSB	Panel Switch Input. (Support 5V and 3V pull-high.)
4	SLP_S5#	IN _{TS}	VSB	SLP_S5# input.
5	SDA	I/OD _{12TS}	VSB	SMBus slave bi-directional Data. (5V or 3V)

6	SCLK	IN _{TS}	VSB	SMBus Address: 0x6C SMBus slave clock. Support 100K (5V or 3V)
7	PS_OUT# (DETECT SYS_3VSB)	AIN/ OD ₁₂	VSB	Panel Switch Output. This signal is used to wake-up the system from S3/S5 state. (Detect Level: 2.95V) The circuit must use 1KΩ resistor and connect to SYS_3VSB or 3VDual power source for power detection.
8	SYS5VSB_OFF	OD ₁₂	VSB	This pin is to control system power for entering deeper power saving mode (Deep S3/ S5 State).
9	GND	P	VSB	Ground.

6. CONTROL AND STATUS REGISTER

6.1 Deep Sleep Enable Control Register (DPSENCTRL)

Location: Address **00**_{HEX}

Type: Read / Write

Power Well : VSB

Reset: Power On Reset

Default Value: **3C**_{HEX} / **3D**_{HEX}

Bit	7	6	5	4	3	2	1	0
Name	Reserved		PSOUT_N_WIDTH[5:4]		PSOUT_N_DLY[3:2]		Reserved	DpS5_En

Bit	Description
7-6	Reserved, don't change the default value
5-4	Deep sleep wake-up PS_OUT# pulse width: When system wake up from deep sleep mode, system will occur a low pulse via PS_OUT#.: 00: Don't occur low pulse 01: Pulse Width 32ms 10: Pulse Width 64ms 11: Pulse Width 160ms (default)
3-2	Deep sleep wake-up PS_OUT# delay time : When system wake up from deep sleep mode, system will occur a low pulse via PS_OUT# after SYS_3VSB ready and wait a delay time.. 00: Delay 5ms 01: Delay 20ms 10: Delay 80ms 11: Delay 160ms (default)
1	Reserved, don't change the default value
0	Deep S5 Enable : Default value was determined by pin1 power on strapping. Strapping to High, the default value of the bit is set to "1". Strapping to Low, the default value of this bit is set to "0". 0: Disable Deep S5 1: Enable Deep S5

6.2 Deep S5 Delay Time Control (DELAYCTRL)

Location: Address **15**_{HEX}
 Type: Read / Write
 Power Well : VSB
 Reset: Power On Reset
 Default Value: **00**_{HEX} / **02**_{HEX}

Bit	7	6	5	4	3	2	1	0
Name	Reserved		Reserved		Reserved		Delay_Time_Control [1:0]	

Bit	Description
7-2	Reserved
1-0	<p>Delay_Time_Control: Delay (0 /3 /6 /10) seconds to enter deep S5 state Default value was determined by pin1 power on strapping. Strapping to High, the default value of these two bits is set to "10" (6 seconds). Strapping to Low, the default value of these two bits is set to "00" (0 second).</p> <p>00: 0 second; 01: 3 seconds; 10: 6 seconds; 11: 10 seconds.</p>

6.3 Chip and Version ID Register (CVID)

Location: Address **20**_{HEX}
 Type: Read Only
 Power Well : VSB
 Reset: Power On Reset
 Default Value: **88**_{HEX}

Bit	7	6	5	4	3	2	1	0
Name	Chip_ID[4:0]					Ver_ID[2:0]		

Bit	Description
7-3	<p>Chip ID : 10001 (default)</p>
2-0	<p>Version ID : 000 : (default)</p>

7. ELECTRICAL CHARACTERISTIC

7.1 ABSOLUTE MAXIMUM RATINGS

PARAMETER	RATING	UNIT
Power Supply Voltage (VSB)	-0.3 ~ 6.0	V
Input Voltage	-0.3 to VSB+0.3	V
Operating Temperature	0 to +70	°C
Storage Temperature	-50 to +150	°C

Note: Exposure to conditions beyond those listed under Absolute Maximum Ratings may adversely affect the life and reliability of the device.

7.2 DC CHARACTERISTICS

PARAMETER	SYM	MIN	TYP	MAX.	UNIT	CONDITIONS
Supply Input Voltage						
VSB Input Voltage	VSB			5.5	V	
Supply Input Current						
VSB Input Current	I _{VSB}		2	5	mA	
I/OD_{12TS} –TTL level and Schmitt trigger open-drain output with 12mA sink capability						
Input Low Threshold Voltage	V _{t-}			0.85	V	
Input High Threshold Voltage	V _{t+}	2.2			V	
Hysteresis	V _{TH}		1.25			
Output Low Voltage	V _{OL}			0.4	V	I _{OL} = 12 mA
Input High Leakage	I _{LIH}			+10	μA	
Input Low Leakage	I _{LIL}			-10	μA	
OUT – 3.3V output pin with 12mA source and sink capability						
Output Low Voltage	V _{OL}			0.4	V	I _{OL} = 12 mA
Output High Voltage	V _{OH}	2.4			V	I _{OH} = -12 mA
OD₁₂ – Open-drain output pin with 12mA sink capability						
Output Low Voltage	V _{OL}			0.4	V	I _{OL} = 12 mA
IN – TTL-level input pin						
Input Low Voltage	V _{IL}			0.8	V	
Input High Voltage	V _{IH}	2.0			V	
Input High Leakage	I _{LIH}			+10	μA	
Input Low Leakage	I _{LIL}			-10	μA	

PARAMETER	SYM	MIN	TYP	MAX.	UNIT	CONDITIONS
IN_{TS} – TTL-level, Schmitt-trigger input pin						
Input Low Threshold Voltage	V _{t-}			0.85	V	
Input High Threshold Voltage	V _{t+}	2.2			V	
Hysteresis	V _{TH}		1.25		V	
Input High Leakage	I _{LIH}			+10	μA	
Input Low Leakage	I _{LIL}			-10	μA	

7.3 AC CHARACTERISTICS

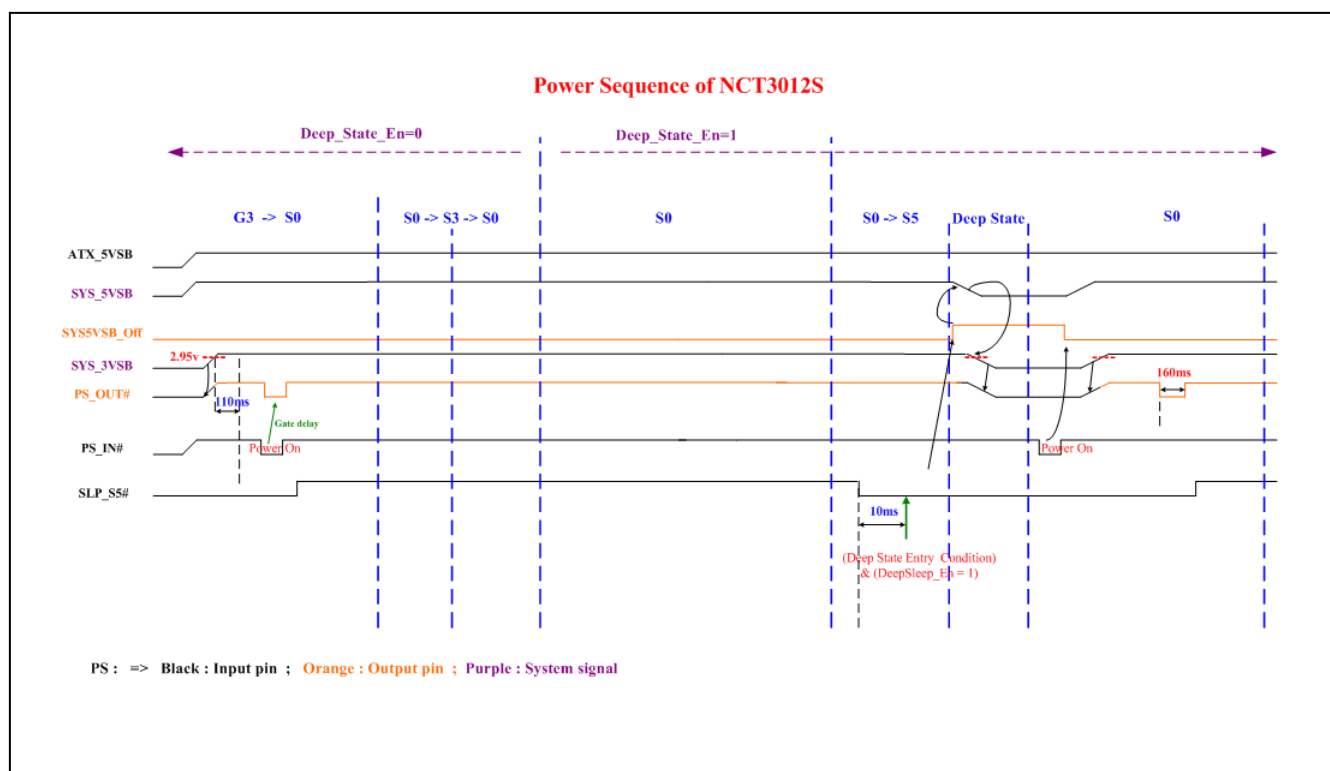

8. TYPICAL APPLICATION REFERENCE CIRCUIT

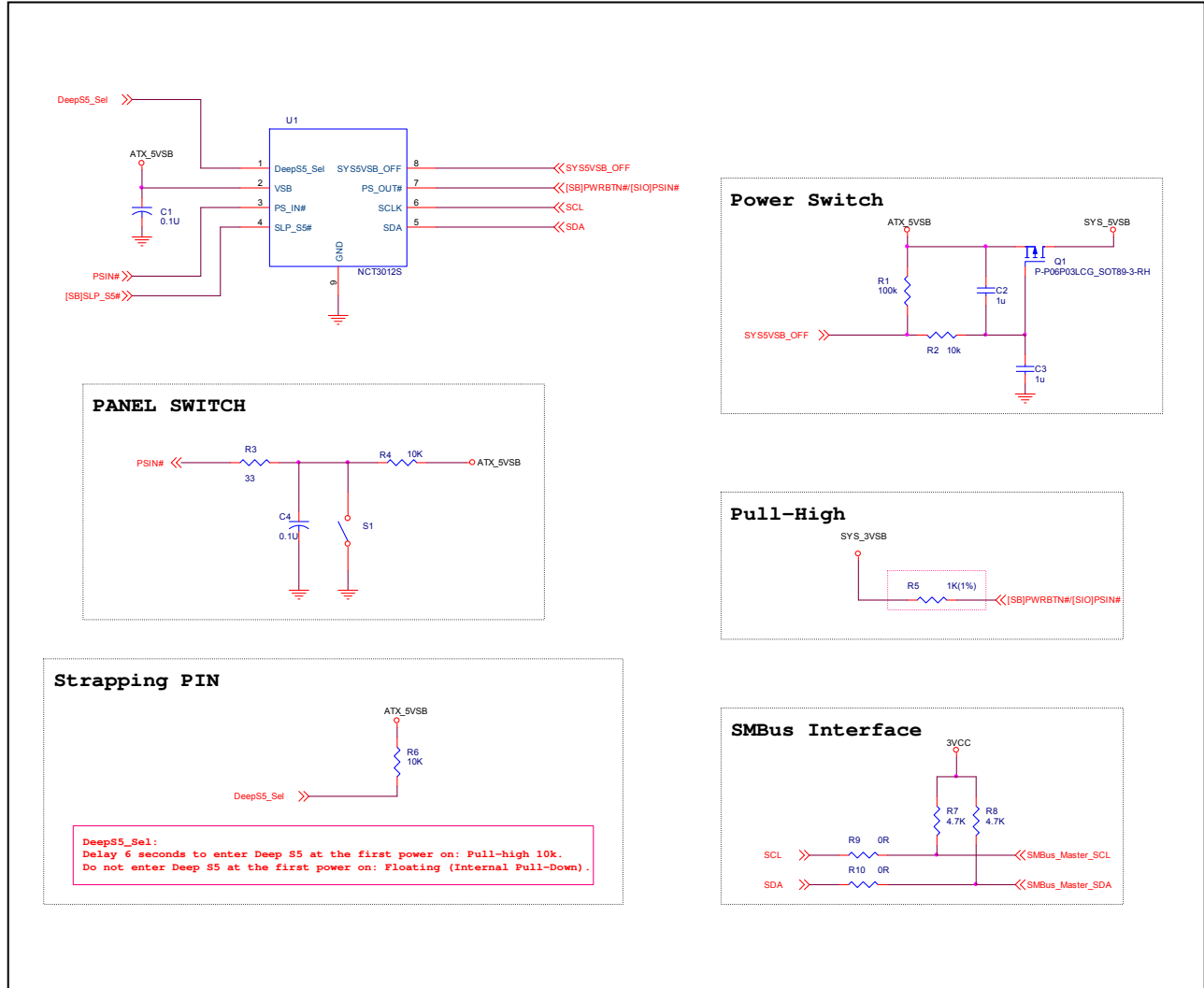

9. PACKAGE SPECIFICATIONS

ESOP-8 (150mil) PKG Outline

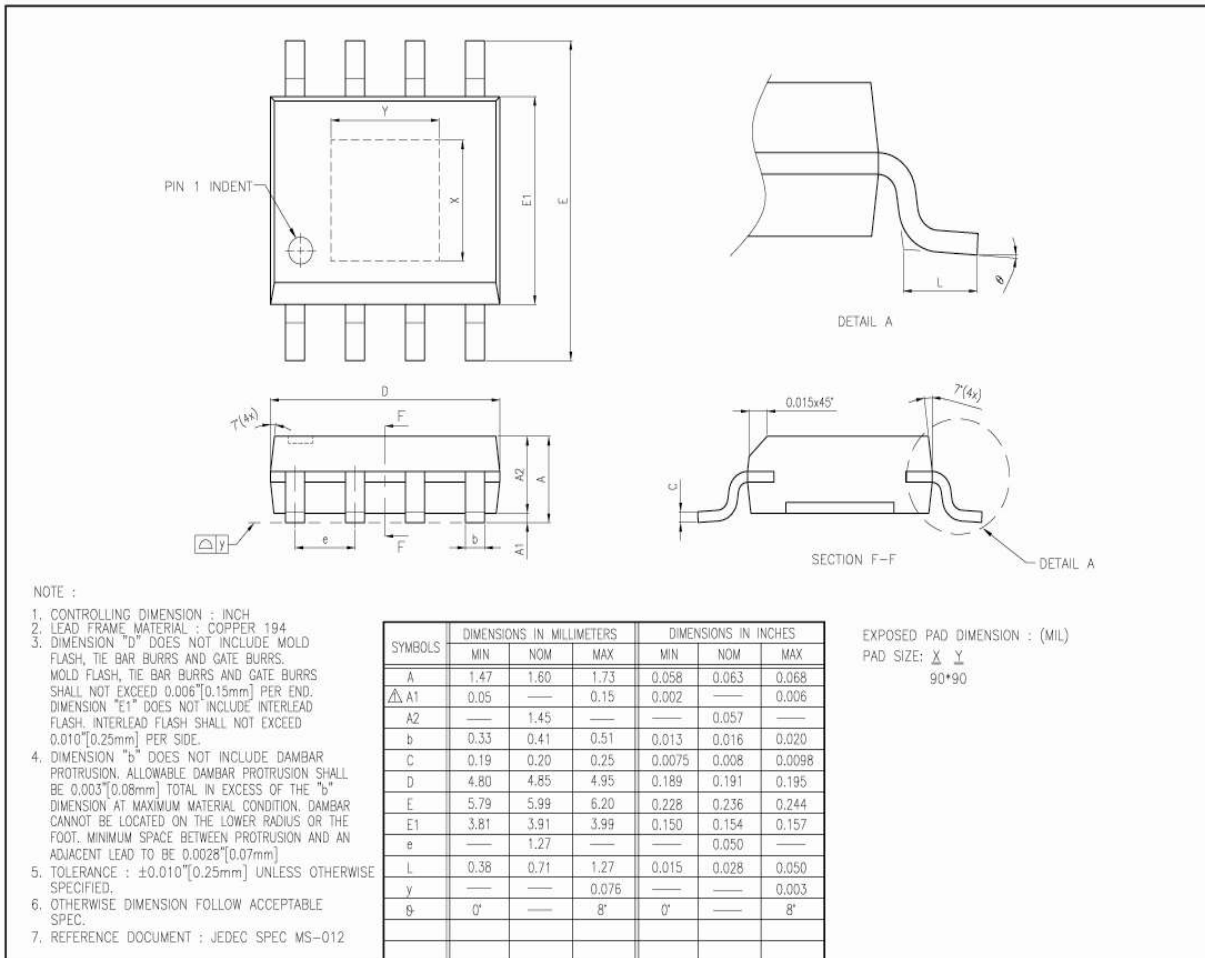

9.1 Taping Specification

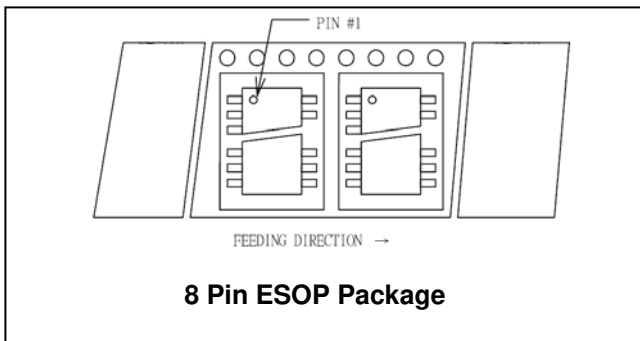

10. Ordering Information

PART NUMBER	PACKAGE TYPE	SUPPLIED AS	PRODUCTION FLOW
NCT3012S	8PIN ESOP (Green package)	2,500 units/ T&R	Commercial, 0°C to +70°C

11. TOP MARKING SPECIFICATIONS

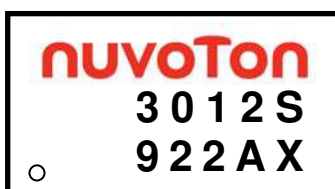

1st line: nuvoTon – company name
 2nd line: 3012S – the part number
 3rd line: Tracking code 922 A X
922: Packages assembled in Year 09', week 22
A: Assembly house ID
X: The IC version (A means A; B means B...etc)

12. REVISION HISTORY

VERSION	DATE	PAGE	DESCRIPTION
A0	07/10/2009	ALL	Preliminary Release

Important Notice

Nuvoton Products are neither intended nor warranted for usage in systems or equipment, any malfunction or failure of which may cause loss of human life, bodily injury or severe property damage. Such applications are deemed, "Insecure Usage".

Insecure usage includes, but is not limited to: equipment for surgical implementation, atomic energy control instruments, airplane or spaceship instruments, the control or operation of dynamic, brake or safety systems designed for vehicular use, traffic signal instruments, all types of safety devices, and other applications intended to support or sustain life.

All Insecure Usage shall be made at customer's risk, and in the event that third parties lay claims to Nuvoton as a result of customer's Insecure Usage, customer shall indemnify the damages and liabilities thus incurred by Nuvoton.

*Please note that all data and specifications are subject to change without notice.
All the trademarks of products and companies mentioned in this datasheet belong to their respective owners.*