

THESE DRAWINGS ARE THE PROPERTY OF QUALTEK ELECTRONICS AND NOT TO BE REPRODUCED FOR OR COMMUNICATED TO A THIRD PARTY WITHOUT THE EXPRESS WRITTEN PERMISSION OF AN OFFICER OF QUALTEK ELECTRONICS.

REVISION			
REV.	DESCRIPTION	DATE	APPROVED
A	Changed Cable Spec	03-12-07	DP
B	Updated Pin Out, Notes and Graphics	08-27-15	LY
C	Updated Pin Out	10-04-17	LY

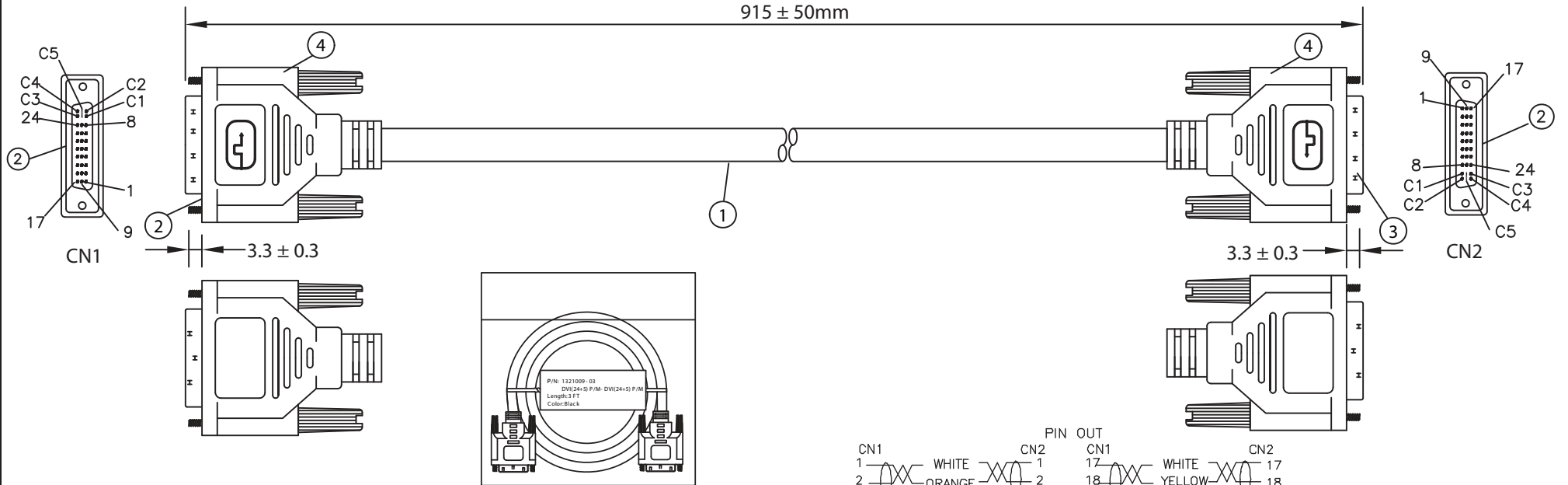

NOTES:

- CABLE: UL20276**
(28AWG*1PR+EAM)*7+(28AWG*1PR+SAM)*3+28AWG*1PR
+28AWG*5C+AEB(AL) 65%
PVC OUTER JACKET: BLACK, OD: 9.5 ± 0.3mm
- CONNECTOR: DVI 24+5 MALE**
INSULATOR: BLACK
PIN G/F
NICKEL PLATED SHELL
THUMB SCREW: E4*28.5mm #4-40UNC
- CONNECTOR: DVI 24+5 MALE**
INSULATOR: BLACK
PIN G/F
NICKEL PLATED SHELL
THUMB SCREW: E4*28.5mm #4-40UNC
- PVC MOLDED: COLOR V398 45P BLACK**
- ELECTRICAL TEST:**
<1>.100% OPEN SHORT & MISS WIRE TEST
<2>.INSULATION RESISTANCE: AC300V DC400V 10M ohm MIN.
<3>.CONDUCTOR RESISTANCE: 3 ohm MAX.
- PACKING: 1PC/POLYBAG**

PIN OUT					
CN1	1	WHITE	CN2	1	WHITE
	2	ORANGE		2	YELLOW
	3	DRAIN		3	DRAIN
	4	DRAIN		4	DRAIN
	5	WHITE		5	WHITE
	6	BROWN		6	GREEN
	7	ORANGE		7	DRAIN
	8	YELLOW		8	WHITE
	9	GREEN		9	RED
	10	WHITE		10	RED(CEN)
	11	BLACK		11	GREEN(CEN)
	12	DRAIN		12	BLUE(CEN)
	13	DRAIN		13	BLUE
	14	WHITE		14	BLUE
	15	BLUE		15	BLUE
	16	RED		16	BLUE
	17	RED		17	GREEN(S)+BLUE(S)+RED(S)
	18	VIOLET		18	
	19	WHITE		19	
	20	RED		20	
	21	ORANGE		21	
	22	GREEN		22	
	23	YELLOW		23	
	24	WHITE		24	
	C1	RED(CEN)		C1	RED(CEN)
	C2	GREEN(CEN)		C2	GREEN(CEN)
	C3	BLUE(CEN)		C3	BLUE(CEN)
	C4	BLUE		C4	BLUE
	C5	GREEN(S)+BLUE(S)+RED(S)		C5	GREEN(S)+BLUE(S)+RED(S)
	SHELL	BRAID& DRAIN		SHELL	BRAID& DRAIN

CONTROLLED

Dim range (mm)		Tolerance +/- (mm)	Qualtek Electronics Corp. WCI DIVISION		
0-1	0.15	Part Number: 1321009-03 RoHS Compliant	Description: DVI (24+5)P/M - DVI (24+5)P/M		
1-6	0.20		UNIT: mm REV.C		
6-18	0.30		Drawn / Date		
18-50	0.50		Checked / Date		
50-120	0.70		Approved / Date		
120-250	0.90	B. Grubb 01-12-07	01-12-07	JJH / 01-12-07	
250-500	1.20				