

MA01F030VABBR300

Product Details

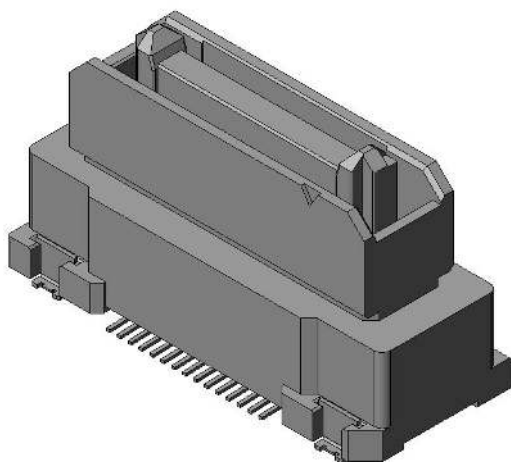

Features

Floating Board-to-board Connector, 8 Gbps+ high-speed transmission (10GBASE-KR and PCIe Gen3 equivalent), Automotive Grade, 30 pos., 0.635mm pitch, 12.3 mm height, Floating side Straight type

Part Number	MA01F030VABBR300
Status	Active
Number of Positions	30 pos.
Contact Pitch	0.635 mm pitch
Rated Current	0.5 A
Rated Voltage	AC 50 Vr.m.s.
Applications	On board equipment (ADAS-ECU, Central gateway, etc.), FA equipment, semiconductor manufacturing equipment, office machines, communication equipment, measuring equipment, broadcasting equipment and other various applications
Connector Type	Floating side
Connector Style	Straight
PCB Mounting Method	Soldering (SMT)

Material of Contact	Copper alloy
Finish of Contact in Connecting Area	Gold plating
Minimum Thickness of The Plating Contact Area	0.1 micrometer min.
Finish of Contact in PCB Mounting Area	Gold plating
Material of Insulator	LCP
PCB Mounted Height	12.3 mm
Existence of Polarization Key	With Key
Existence of Location Boss	With Boss
PCB Boardlock Feature	Hold-down
Body Length	20.925 mm
Body Breadth	8.8 mm
Operating Temperature Range	-40 deg. C to +125 deg. C
Mating Cycles	100 mating cycles
Finish of Hold-down	Copper alloy/ Tin plating
Packaging Type	Embossed tape packaging
Quantity in The Standard Packaging	300 pieces/ reel
RoHS compliant	10 substances (2011/65/EU, (EU)2015/863)
REACH compliant	233 substances (17/01/2023)
Combination	MA01R030VABBR600 MA01R030VANBR200 MA01R030HAYBR600 MA01R030VADBR500

Notice

1. The values specified in this web site are only for reference. The products and their specifications are subject to change without notice. Contact our sales staff for further information before considering or ordering any of our products.

For purchase, a product specification must be agreed upon.

2. Users are requested to provide protection circuits and redundancy circuits to ensure safety of the equipment, and sufficiently review the suitability of JAE's products to the equipment.

3. The products presented in this web site are designed for the uses recommended below.

We strongly suggest you contact our sales staff when considering use of any of the products in any other way than the recommended applications or for a specific use that requires an extremely high reliability.

(1) Applications that require consultation:

* Please contact us if you are considering use involving a quality assurance program that you specify or that is peculiar to the industry, such as:

Automotive electrical components, train control, telecommunications devices (mainline), traffic light control, electric power, combustion control, fire prevention or security systems, disaster evention equipment, etc.

* We may separately give you our support with a quality assurance program that

you specify, when you think of a use such as :

Aviation or space equipment, submarine repeaters, nuclear power control systems, medical equipment for life support, etc.

(2) Recommended applications include:

* Computers, office appliances, telecommunications devices (terminals, mobile units), measuring equipment, audiovisual equipment, home electric appliances, factory automation

equipment, etc