



## STEREO DIGITAL AUDIO LIP-SYNC DELAY

### FEATURES

- Digital Audio Format: 16-24-bit I<sup>2</sup>S
- Single Serial Input Port
- Delay Time: 170 ms/ch at  $f_s = 48$  kHz
- Delay Resolution: 256 samples
- Delay Memory Cleared on Power-Up or After Delay Changes
  - Eliminates Erroneous Data From Being Output
- 3.3 V Operation With 5 V Tolerant I/O
- Supports Audio Bit Clock Rates of 32 to 64 fs with  $f_s = 32$  kHz–192 kHz
- No External Crystal or Oscillator Required
  - All Internal Clocks Generated From the Audio Clock
- Surface Mount 4mm × 4mm, 16-pin QFN Package

### APPLICATIONS

- High Definition TV Lip-Sync Delay
- Flat Panel TV Lip-Sync Delay
- Home Theater Rear-Channel Effects
- Wireless Speaker Front-Channel Synchronization
- Camcorders

### DESCRIPTION

The TPA5052 accepts a single serial audio input, buffers the data for a selectable period of time, and outputs the delayed audio data on a single serial output. In systems with complex video processing algorithms, one device allows delay of up to 170 ms/ch ( $f_s = 48$  kHz) to synchronize the audio stream to the video stream. If more delay is needed, the devices can be connected in series.

### SIMPLIFIED APPLICATION DIAGRAM

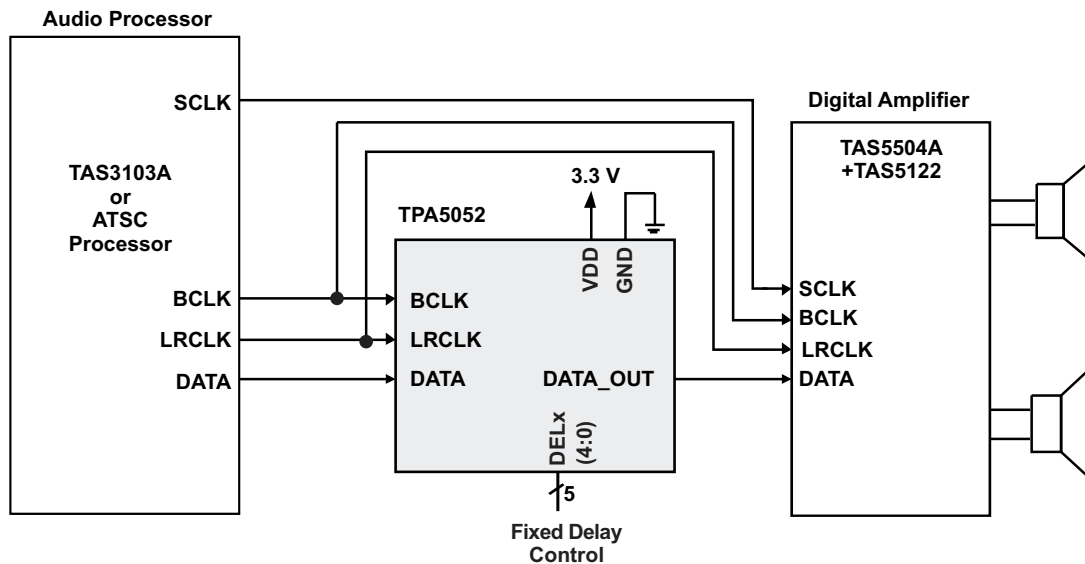

Please be aware that an important notice concerning availability, standard warranty, and use in critical applications of Texas Instruments semiconductor products and disclaimers thereto appears at the end of this data sheet.



These devices have limited built-in ESD protection. The leads should be shorted together or the device placed in conductive foam during storage or handling to prevent electrostatic damage to the MOS gates.

## PIN DESCRIPTIONS

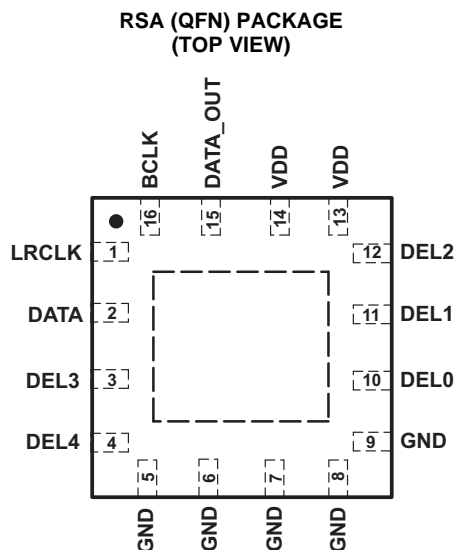

## TERMINAL FUNCTIONS

TERMINAL		I/O	DESCRIPTION
NAME	NO.		
DEL0	10	I	Delay select pin – LSB. 5V tolerant input.
DEL1	11	I	Delay select pin. 5V tolerant input.
DEL2	12	I	Delay select pin. 5V tolerant input.
DEL3	3	I	Delay select pin. 5V tolerant input.
DEL4	4	I	Delay select pin - MSB. 5V tolerant input.
BCLK	16	I	Audio data bit clock input for serial input. 5V tolerant input.
DATA	2	I	Audio serial data input for serial input. 5V tolerant input.
DATA_OUT	15	O	Delayed audio serial data output.
GND	5–9	P	Ground – All ground terminals must be tied to GND for proper operation
LRCLK	1	I	Left and Right serial audio sampling rate clock (fs). 5V tolerant input.
VDD	13, 14	P	Power supply interface. Both pins must be tied to power supply.
Thermal Pad		-	Connect to ground. Must be soldered down in all applications to properly secure device on the PCB.

## FUNCTIONAL BLOCK DIAGRAM

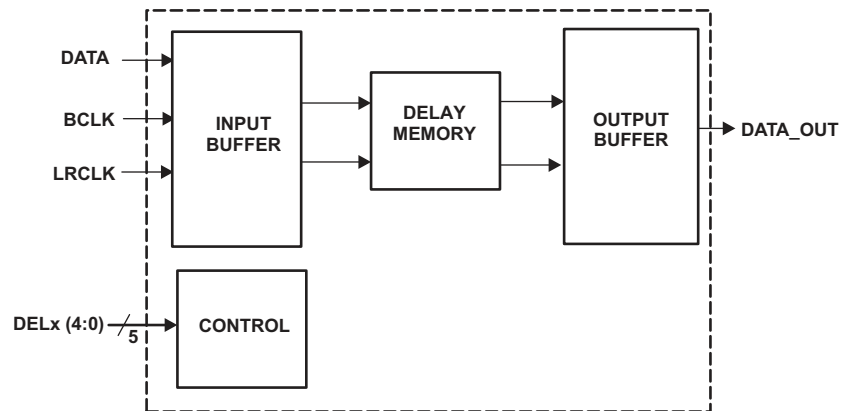

## ABSOLUTE MAXIMUM RATINGS

over operating free-air temperature (unless otherwise noted) <sup>(1)</sup>

		VALUE	UNIT
V <sub>DD</sub>	Supply voltage	-0.3 to 3.6	V
V <sub>I</sub>	Input voltage	DATA, LRCLK, BCLK, DEL[4:0]	-0.3 to 5.5
Continuous total power dissipation		See Dissipation Rating Table	
T <sub>A</sub>	Operating free-air temperature range	-40 to 85	°C
T <sub>J</sub>	Operating junction temperature range	-40 to 125	°C
T <sub>stg</sub>	Storage temperature range	-65 to 125	°C
Lead temperature 1,6 mm (1/16 inch) from case for 10 seconds		260	°C

(1) Stresses beyond those listed under *absolute maximum ratings* may cause permanent damage to the device. These are stress ratings only, and functional operations of the device at these or any other conditions beyond those indicated under *recommended operating conditions* is not implied. Exposure to absolute-maximum-rated conditions for extended periods may affect device reliability.

## DISSIPATION RATINGS<sup>(1)</sup>

PACKAGE	T <sub>A</sub> ≤ 25°C POWER RATING	DERATING FACTOR	T <sub>A</sub> = 70°C POWER RATING	T <sub>A</sub> = 85°C POWER RATING
RSA	2.5 W	25 mW/°C	1.375 W	1 W

(1) This data was taken using 1 oz trace and copper pad that is soldered directly to a JEDEC standard high-k PCB. The thermal pad must be soldered to a thermal land on the printed-circuit board. See TI Technical Briefs [SCBA017D](#) and [SLUA271](#) for more information about using the QFN thermal pad.

## RECOMMENDED OPERATING CONDITIONS

			MIN	MAX	UNIT
V <sub>DD</sub>	Supply voltage	VDD	3	3.6	V
V <sub>IH</sub>	High-level input voltage	DATA, LRCLK, BCLK, DEL[4:0]	2		V
V <sub>IL</sub>	Low-level input voltage	DATA, LRCLK, BCLK, DEL[4:0]		0.8	V
T <sub>A</sub>	Operating free-air temperature		-40	85	°C

### DC CHARACTERISTICS

T<sub>A</sub> = 25°C, V<sub>DD</sub> = 3 V (unless otherwise noted)

PARAMETER	TEST CONDITIONS	MIN	TYP	MAX	UNIT
I <sub>DD</sub>	Supply current V <sub>DD</sub> = 3.3 V, f <sub>s</sub> = 48 kHz, BCLK = 32 × f <sub>s</sub>		1.8	3	mA
I <sub>OH</sub>	High-level output current DATA_OUT = 2.6 V	5		13	mA
I <sub>OL</sub>	Low-level output current DATA_OUT = 0.4 V	5		13	mA
I <sub>IH</sub>	High-level input current DATA, LRCLK, BCLK, V <sub>I</sub> = 5.5V, V <sub>DD</sub> = 3V			20	μA
	DEL[4:0], V <sub>I</sub> = 3.6V, V <sub>DD</sub> = 3.6V			5	
I <sub>IL</sub>	Low-level input current DATA, LRCLK, BCLK, DEL[4:0], V <sub>I</sub> = 0V, V <sub>DD</sub> = 3.6V			1	μA

### Serial Audio Input Ports

over recommended operating conditions (unless otherwise noted)

PARAMETER	TEST CONDITIONS	MIN	TYP	MAX	UNIT
f <sub>SCLKIN</sub>	Frequency, BCLK 32 × f <sub>s</sub> , 48 × f <sub>s</sub> , 64 × f <sub>s</sub>	1.024	12.288		MHz
t <sub>su1</sub>	Setup time, LRCLK to BCLK rising edge	10			ns
t <sub>h1</sub>	Hold time, LRCLK from BCLK rising edge	10			ns
t <sub>su2</sub>	Setup time, DATA to BCLK rising edge	10			ns
t <sub>h2</sub>	Hold time, DATA from BCLK rising edge	10			ns
LRCLK frequency		32	48	192	kHz
BCLK duty cycle			50%		
LRCLK duty cycle			50%		
BCLK rising edges between LRCLK rising edges	LRCLK duty cycle = 50%	32		64	BCLK edges

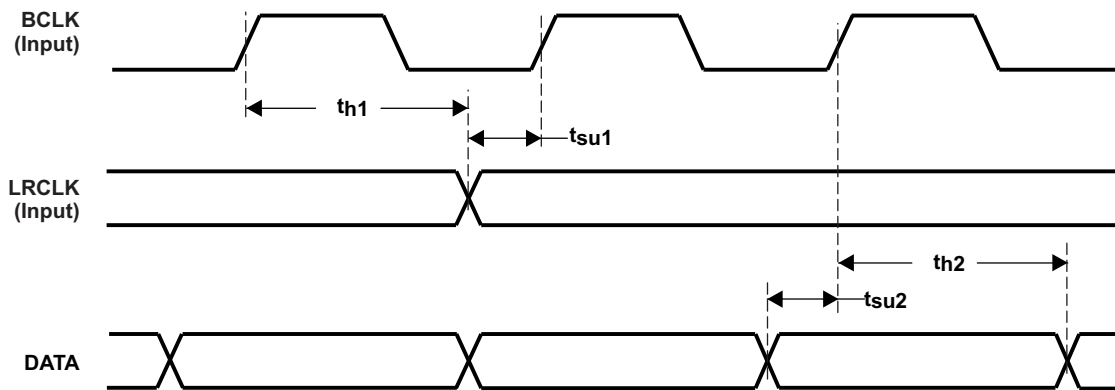

Figure 1. Serial Data Interface Timing

## APPLICATION INFORMATION

### AUDIO SERIAL INTERFACE

The audio serial interface for the TPA5052 consists of a 3-wire synchronous serial port. It includes LRCLK, BCLK, and DATA. BCLK is the serial audio bit clock, and it is used to clock the serial data present on DATA into the serial shift register of the audio interface. Serial data is clocked into the TPA5052 on the rising edge of BCLK. LRCLK is the serial audio left/right word clock. It is used to latch serial data into the internal registers of the serial audio interface. LRCLK is operated at the sampling frequency,  $f_s$ . BCLK can be operated at 32 to 64 times the sampling frequency for I<sup>2</sup>S formats. A system clock is not necessary for the operation of the TPA5052.

### I<sup>2</sup>S TIMING

The I<sup>2</sup>S data format diagram is shown in [Figure 2](#).

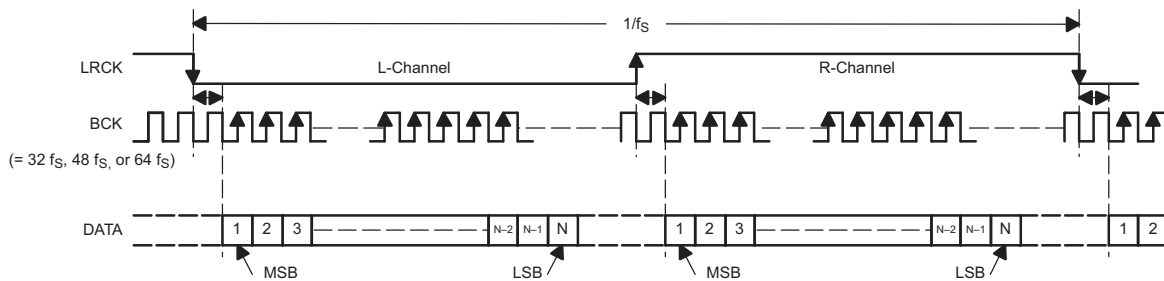

Figure 2. I<sup>2</sup>S Data Format; L-Channel = LOW, R-Channel = HIGH

### GENERAL DELAY OPERATION

The delay of the TPA5052 is set using the 5 delay pins (DEL4, DEL3, DEL2, DEL1, DEL0). The minimum delay is 255 samples, and occurs when all five pins are at logic 0. The maximum delay is 8191 samples, and occurs when all five pins are at logic 1. The delay can be increased by changing the values on each pin from a 0 to a 1. See [Table 1](#). Delay pin DEL4 is the MSB, and DEL0 is the LSB.

The delay is calculated with the following formula:

$$\text{Audio Delay (in samples)} = 4096 \times (\text{DEL4}) + 2048 \times (\text{DEL3}) + 1024 \times (\text{DEL2}) + 512 \times (\text{DEL1}) + 256 \times (\text{DEL0}) + 255$$

$$\text{Audio Delay (ms)} = \text{Audio Delay (in samples)} \times (1/f_s)$$

Both channels have the same amount of delay. They cannot be controlled individually.

Table 1. Delay Settings

DEL4	DEL3	DEL2	DEL1	DEL0	Delay in Samples
0	0	0	0	0	255
0	0	0	0	1	511
0	0	0	1	0	767
0	0	0	1	1	1023
↓	↓	↓	↓	↓	↓
1	1	1	1	1	8191

### TPA5052 Operation

Only a single decoupling capacitor (0.1  $\mu\text{F}$ –1  $\mu\text{F}$ ) is required across VDD and GND. The DELx terminals can be directly connected to VDD or GND. [Table 1](#) describes the delay settings selectable via the DELx terminals. A schematic implementation of the TPA5052 is shown in [Figure 3](#).

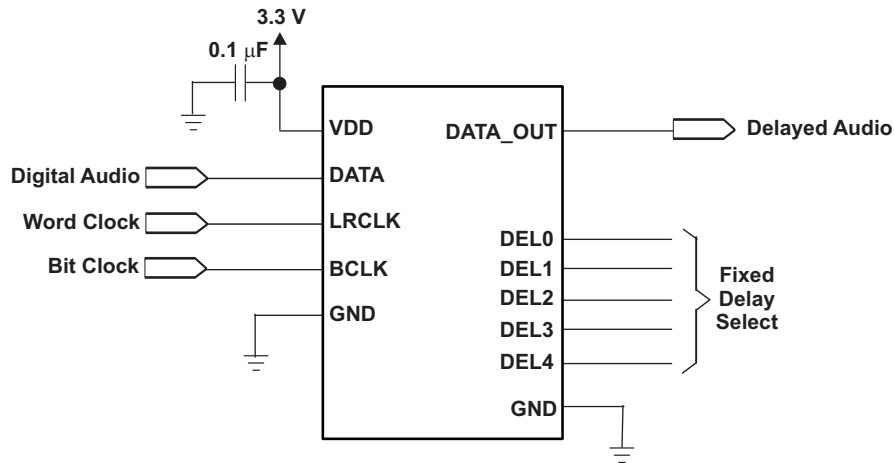

**Figure 3. TPA5052 Schematic**

### COMPLETE UPDATE

To avoid pops and clicks in the audio stream when the delay is changed, the TPA5052 holds each channel in an internal mute mode until all the set number of samples have passed. For example, if the delay is set to 511 samples, the TPA5052 holds each channel in mute until all 511 samples of audio data have passed.

## APPLICATION EXAMPLES

### Connecting Two Devices in Series to Increase the Delay

It is sometimes desirable to increase the delay time beyond the limit which one device provides. In such cases, the TPA5052 device can be placed in a series to increase the delay. See [Figure 4](#) for an example.

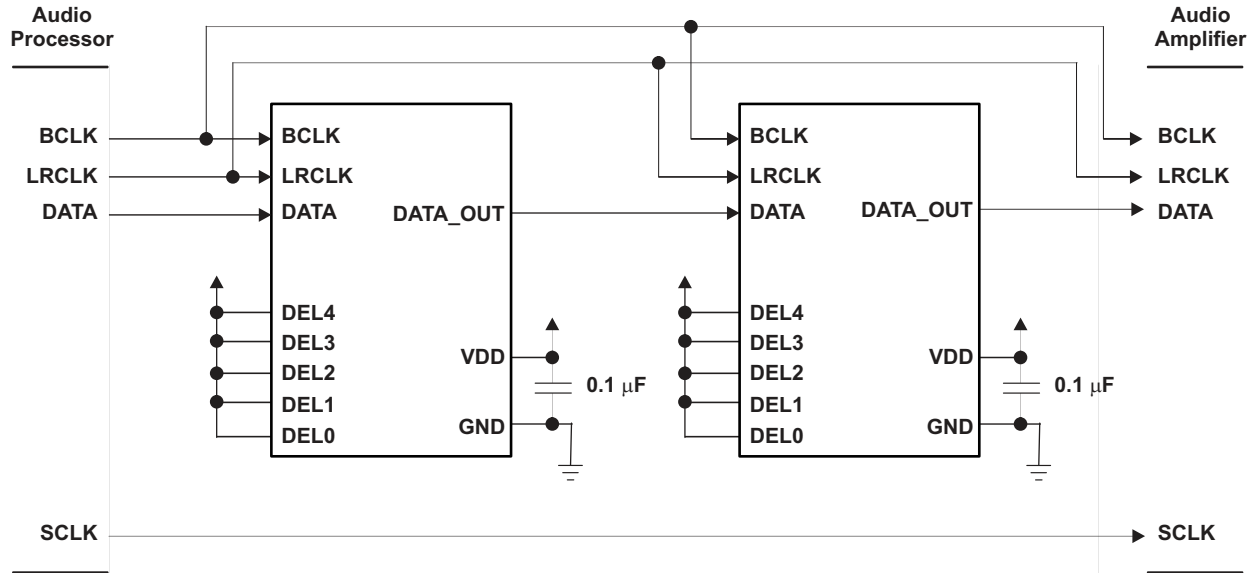

Figure 4. Two Devices in Series

## DEVICE CURRENT CONSUMPTION

The TPA5052 draws different amounts of supply current depending upon the conditions under which it is operated. As  $V_{DD}$  increases, so too does  $I_{DD}$ . Likewise, as  $V_{DD}$  decreases,  $I_{DD}$  decreases. The same is true of the sampling frequency,  $f_s$ . An increase in  $f_s$  causes an increase in  $I_{DD}$ . [Figure 5](#) illustrates the relationship between operating condition and typical supply current.

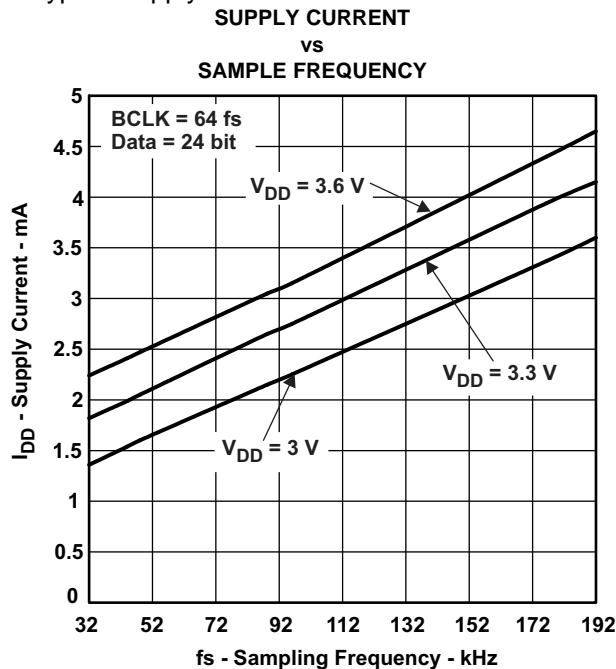



Figure 5. Typical Supply Current

**PACKAGING INFORMATION**

Orderable Device	Status (1)	Package Type	Package Drawing	Pins	Package Qty	Eco Plan (2)	Lead finish/ Ball material (6)	MSL Peak Temp (3)	Op Temp (°C)	Device Marking (4/5)	Samples
TPA5052RSAR	ACTIVE	QFN	RSA	16	3000	RoHS & Green	NIPDAU	Level-2-260C-1 YEAR	-40 to 85	TPA 5052	
TPA5052RSAT	LIFEBUY	QFN	RSA	16	250	RoHS & Green	NIPDAU	Level-2-260C-1 YEAR	-40 to 85	TPA 5052	

(1) The marketing status values are defined as follows:

**ACTIVE:** Product device recommended for new designs.

**LIFEBUY:** TI has announced that the device will be discontinued, and a lifetime-buy period is in effect.

**NRND:** Not recommended for new designs. Device is in production to support existing customers, but TI does not recommend using this part in a new design.

**PREVIEW:** Device has been announced but is not in production. Samples may or may not be available.

**OBsolete:** TI has discontinued the production of the device.

(2) **RoHS:** TI defines "RoHS" to mean semiconductor products that are compliant with the current EU RoHS requirements for all 10 RoHS substances, including the requirement that RoHS substance do not exceed 0.1% by weight in homogeneous materials. Where designed to be soldered at high temperatures, "RoHS" products are suitable for use in specified lead-free processes. TI may reference these types of products as "Pb-Free".

**RoHS Exempt:** TI defines "RoHS Exempt" to mean products that contain lead but are compliant with EU RoHS pursuant to a specific EU RoHS exemption.

**Green:** TI defines "Green" to mean the content of Chlorine (Cl) and Bromine (Br) based flame retardants meet JS709B low halogen requirements of <=1000ppm threshold. Antimony trioxide based flame retardants must also meet the <=1000ppm threshold requirement.

(3) MSL, Peak Temp. - The Moisture Sensitivity Level rating according to the JEDEC industry standard classifications, and peak solder temperature.

(4) There may be additional marking, which relates to the logo, the lot trace code information, or the environmental category on the device.

(5) Multiple Device Markings will be inside parentheses. Only one Device Marking contained in parentheses and separated by a "~" will appear on a device. If a line is indented then it is a continuation of the previous line and the two combined represent the entire Device Marking for that device.

(6) Lead finish/Ball material - Orderable Devices may have multiple material finish options. Finish options are separated by a vertical ruled line. Lead finish/Ball material values may wrap to two lines if the finish value exceeds the maximum column width.

**Important Information and Disclaimer:**The information provided on this page represents TI's knowledge and belief as of the date that it is provided. TI bases its knowledge and belief on information provided by third parties, and makes no representation or warranty as to the accuracy of such information. Efforts are underway to better integrate information from third parties. TI has taken and continues to take reasonable steps to provide representative and accurate information but may not have conducted destructive testing or chemical analysis on incoming materials and chemicals. TI and TI suppliers consider certain information to be proprietary, and thus CAS numbers and other limited information may not be available for release.

In no event shall TI's liability arising out of such information exceed the total purchase price of the TI part(s) at issue in this document sold by TI to Customer on an annual basis.





**TAPE AND REEL INFORMATION**

**QUADRANT ASSIGNMENTS FOR PIN 1 ORIENTATION IN TAPE**

\*All dimensions are nominal

Device	Package Type	Package Drawing	Pins	SPQ	Reel Diameter (mm)	Reel Width W1 (mm)	A0 (mm)	B0 (mm)	K0 (mm)	P1 (mm)	W (mm)	Pin1 Quadrant
TPA5052RSAR	QFN	RSA	16	3000	330.0	12.4	4.25	4.25	1.15	8.0	12.0	Q2
TPA5052RSAT	QFN	RSA	16	250	180.0	12.4	4.25	4.25	1.15	8.0	12.0	Q2

**TAPE AND REEL BOX DIMENSIONS**

\*All dimensions are nominal

Device	Package Type	Package Drawing	Pins	SPQ	Length (mm)	Width (mm)	Height (mm)
TPA5052RSAR	QFN	RSA	16	3000	356.0	356.0	35.0
TPA5052RSAT	QFN	RSA	16	250	210.0	185.0	35.0

RSA (S-PVQFN-N16)

PLASTIC QUAD FLATPACK NO-LEAD

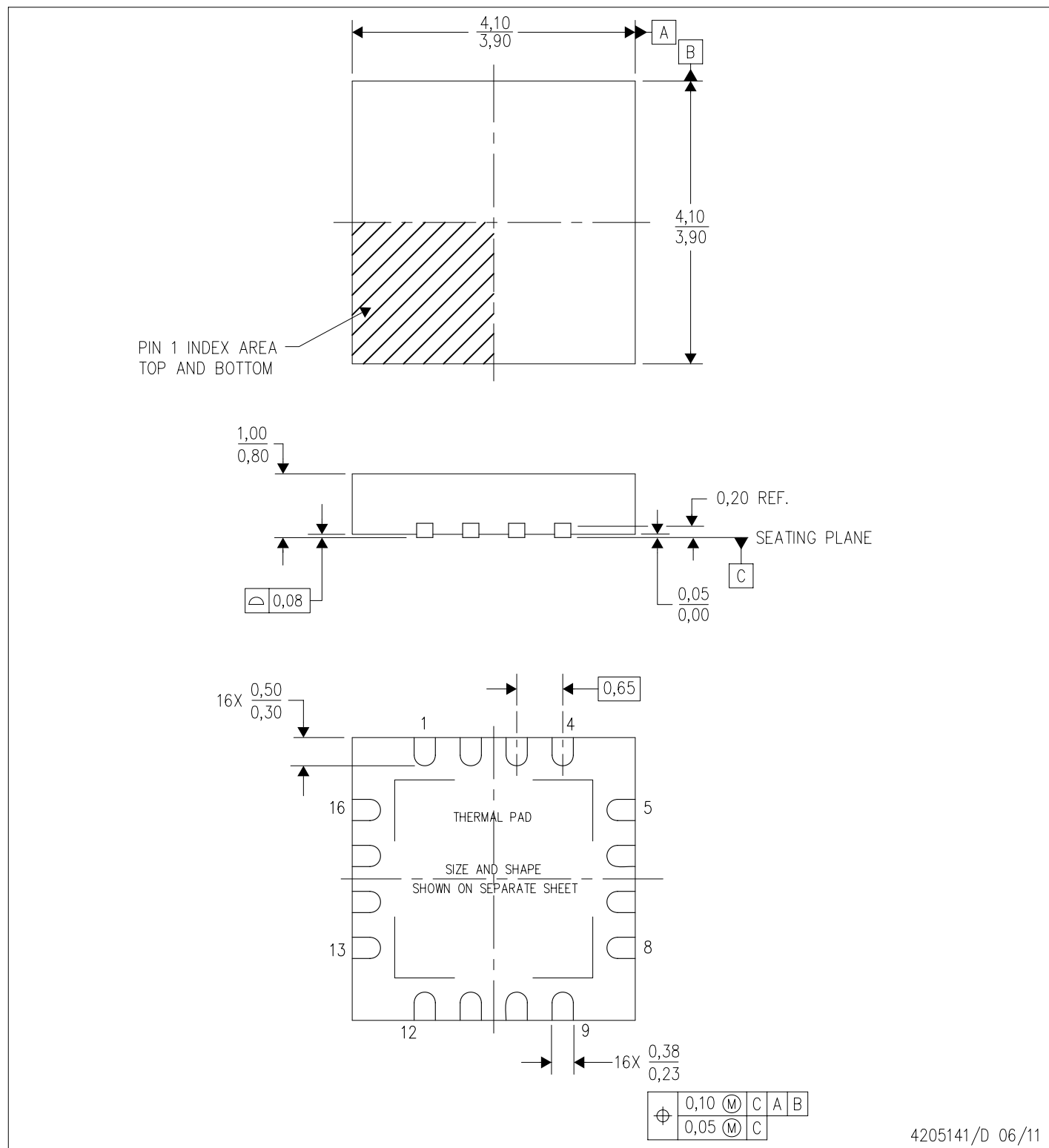

- NOTES:
- All linear dimensions are in millimeters. Dimensioning and tolerancing per ASME Y14.5M-1994.
  - This drawing is subject to change without notice.
  - Quad Flatpack, No-leads (QFN) package configuration.
  - The package thermal pad must be soldered to the board for thermal and mechanical performance.
  - See the additional figure in the Product Data Sheet for details regarding the exposed thermal pad features and dimensions.
  - Falls within JEDEC MO-220.

## THERMAL INFORMATION

This package incorporates an exposed thermal pad that is designed to be attached directly to an external heatsink. The thermal pad must be soldered directly to the printed circuit board (PCB). After soldering, the PCB can be used as a heatsink. In addition, through the use of thermal vias, the thermal pad can be attached directly to the appropriate copper plane shown in the electrical schematic for the device, or alternatively, can be attached to a special heatsink structure designed into the PCB. This design optimizes the heat transfer from the integrated circuit (IC).

For information on the Quad Flatpack No-Lead (QFN) package and its advantages, refer to Application Report, QFN/SON PCB Attachment, Texas Instruments Literature No. SLUA271. This document is available at [www.ti.com](http://www.ti.com).

The exposed thermal pad dimensions for this package are shown in the following illustration.

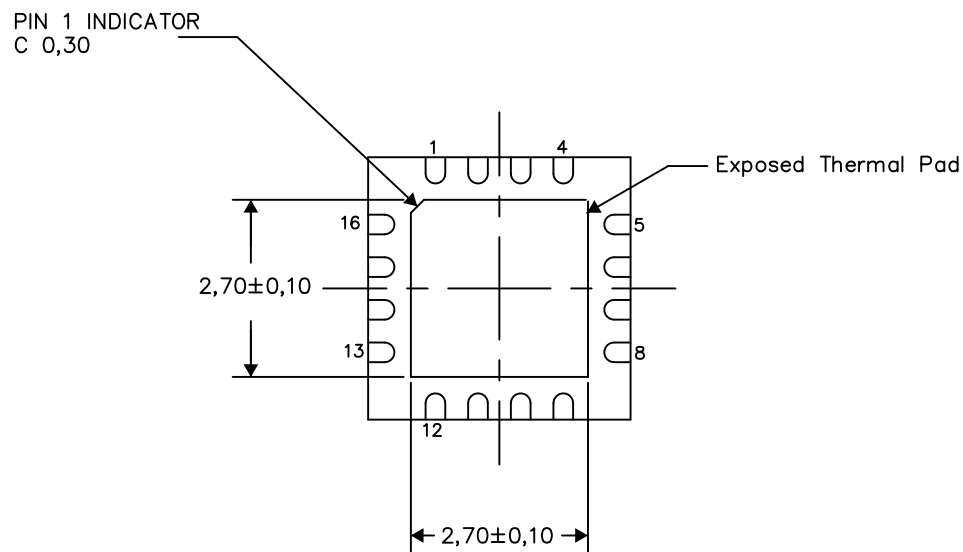

Bottom View

Exposed Thermal Pad Dimensions

4206364-2/0 09/15

### NOTES:

- A. All linear dimensions are in millimeters

RSA (S-PVQFN-N16)

PLASTIC QUAD FLATPACK NO-LEAD

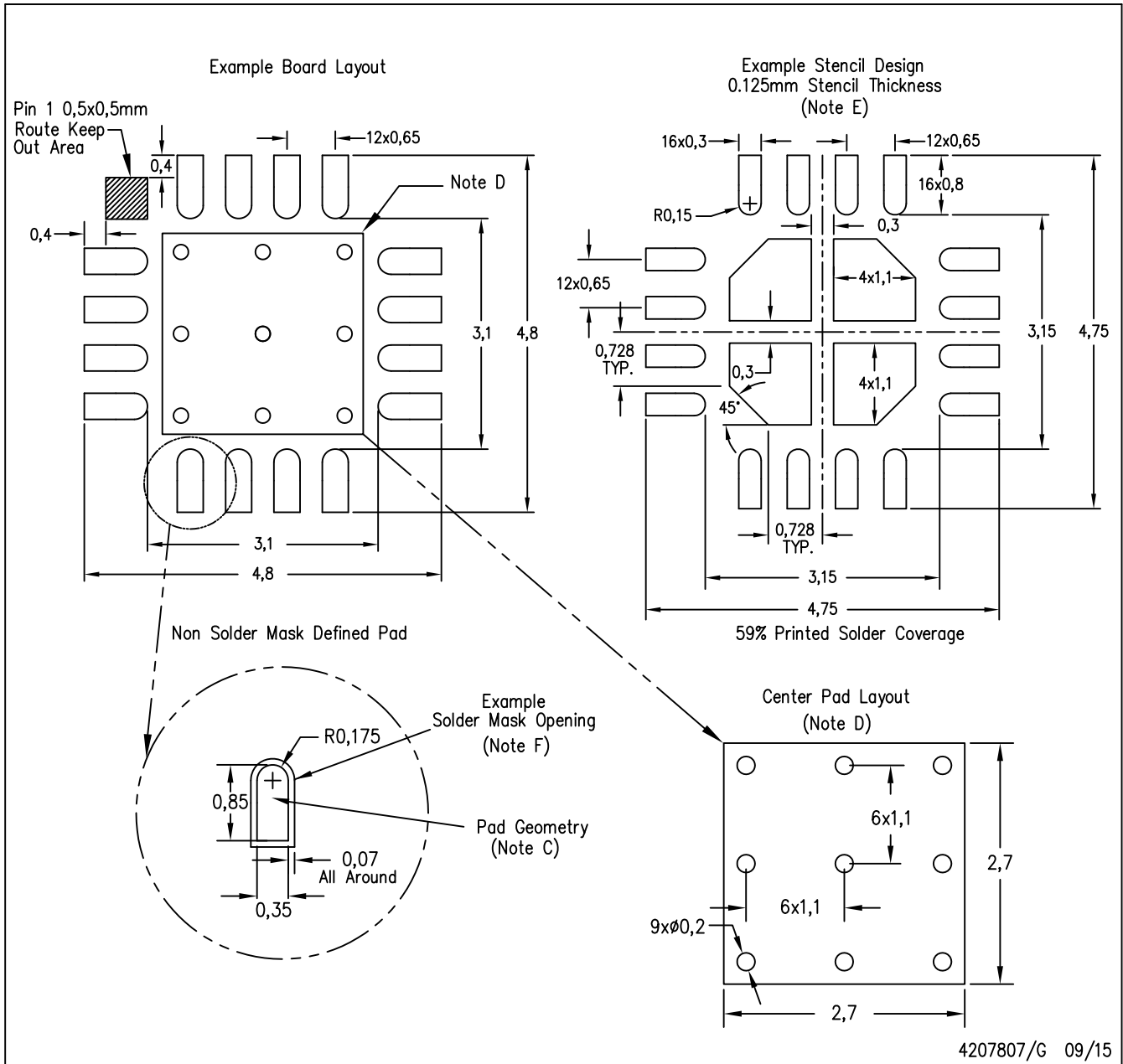

- NOTES:
- A. All linear dimensions are in millimeters.
  - B. This drawing is subject to change without notice.
  - C. Publication IPC-7351 is recommended for alternate designs.
  - D. This package is designed to be soldered to a thermal pad on the board. Refer to Application Note, QFN Packages, Texas Instruments Literature No. SLUA271, and also the Product Data Sheets for specific thermal information, via requirements, and recommended board layout. These documents are available at [www.ti.com](http://www.ti.com) <<http://www.ti.com>>.
  - E. Laser cutting apertures with trapezoidal walls and also rounding corners will offer better paste release. Customers should contact their board assembly site for stencil design recommendations. Refer to IPC 7525 for stencil design considerations.
  - F. Customers should contact their board fabrication site for solder mask tolerances.

## IMPORTANT NOTICE AND DISCLAIMER

TI PROVIDES TECHNICAL AND RELIABILITY DATA (INCLUDING DATA SHEETS), DESIGN RESOURCES (INCLUDING REFERENCE DESIGNS), APPLICATION OR OTHER DESIGN ADVICE, WEB TOOLS, SAFETY INFORMATION, AND OTHER RESOURCES "AS IS" AND WITH ALL FAULTS, AND DISCLAIMS ALL WARRANTIES, EXPRESS AND IMPLIED, INCLUDING WITHOUT LIMITATION ANY IMPLIED WARRANTIES OF MERCHANTABILITY, FITNESS FOR A PARTICULAR PURPOSE OR NON-INFRINGEMENT OF THIRD PARTY INTELLECTUAL PROPERTY RIGHTS.

These resources are intended for skilled developers designing with TI products. You are solely responsible for (1) selecting the appropriate TI products for your application, (2) designing, validating and testing your application, and (3) ensuring your application meets applicable standards, and any other safety, security, regulatory or other requirements.

These resources are subject to change without notice. TI grants you permission to use these resources only for development of an application that uses the TI products described in the resource. Other reproduction and display of these resources is prohibited. No license is granted to any other TI intellectual property right or to any third party intellectual property right. TI disclaims responsibility for, and you will fully indemnify TI and its representatives against, any claims, damages, costs, losses, and liabilities arising out of your use of these resources.

TI's products are provided subject to [TI's Terms of Sale](#) or other applicable terms available either on [ti.com](https://www.ti.com) or provided in conjunction with such TI products. TI's provision of these resources does not expand or otherwise alter TI's applicable warranties or warranty disclaimers for TI products.

TI objects to and rejects any additional or different terms you may have proposed.

Mailing Address: Texas Instruments, Post Office Box 655303, Dallas, Texas 75265  
Copyright © 2023, Texas Instruments Incorporated