

Click [here](#) for production status of specific part numbers.

MAX14514

Dual Electroluminescent Lamp Driver

General Description

The MAX14514 is a high-voltage DC-AC converter ideal for driving two electroluminescent (EL) lamps. The MAX14514 features a +2.7V to +5.5V input range that allows the device to accept a wide variety of voltage sources, including single-cell lithium-ion (Li+) batteries. The lamp outputs of the device generate up to 300VP-P for maximum lamp brightness.

The MAX14514 utilizes an inductor-based boost converter to generate the high voltage necessary to drive EL lamps and allows the use of a 220 μ H inductor to effectively drive total combined lamp sizes of up to 20nF.

The MAX14514 uses a high-voltage full-bridge output stage to convert the high voltage generated by the boost converter to an AC waveform suitable for driving the EL panels. An external resistor controls the slew-rate of the rising and falling edges of the AC drive waveform to reduce audible noise output. The high-voltage outputs are ESD protected up to ± 15 kV Human Body Model, ± 4 kV IEC 61000-4-2 Air Gap Discharge, and ± 4 kV IEC 61000-4-2 Contact Discharge.

The MAX14514 features dimming/enable controls (DIM1, DIM2) for each output to allow the user to set the peak-to-peak output voltage with a PWM signal, a DC analog voltage, or a resistor connected from DIM_ to GND. The MAX14514 also provides a slow turn-on/off feature that slowly ramps the output voltage applied to the lamp when enabled or disabled.

The MAX14514 enters a low-power shutdown mode when the EN and DIM_ inputs are connected to GND. The device also features thermal shutdown if the die temperature exceeds +158 $^{\circ}$ C (typ).

The MAX14514 is available in a space-saving, 14-pin, 3mm x 3mm TDFN package and is specified over the extended -40 $^{\circ}$ C to +85 $^{\circ}$ C operating temperature range.

Applications

- I Keypad Backlighting
- LCD Backlighting
- PDAs/Smartphones

Benefits and Features

- Dual ± 15 kV ESD-Protected EL Lamp Outputs
- 300V_{P-P} Maximum Output for Highest Brightness
- +2.7V to +5.5V Input Voltage Range
- Resistor Adjustable Slew-Rate Control
- Resistor Adjustable Lamp and Switching Converter Frequencies
- DIM Input for Controlling Output Voltage Through DC Analog Voltage, PWM, or Resistor to GND
- Capacitor Adjustable Soft Turn-On/-Off
- Low 150nA Shutdown Current
- Thermal Shutdown
- Space Saving, 14-Pin, 3mm x 3mm TDFN Package

Ordering Information

PART	TEMP RANGE	PIN-PACKAGE
MAX14514ETD+	-40 $^{\circ}$ C to +85 $^{\circ}$ C	14 TDFN-EP*

+Denotes lead(Pb)-free/RoHS-compliant package.

*EP = Exposed paddle.

Pin Configuration

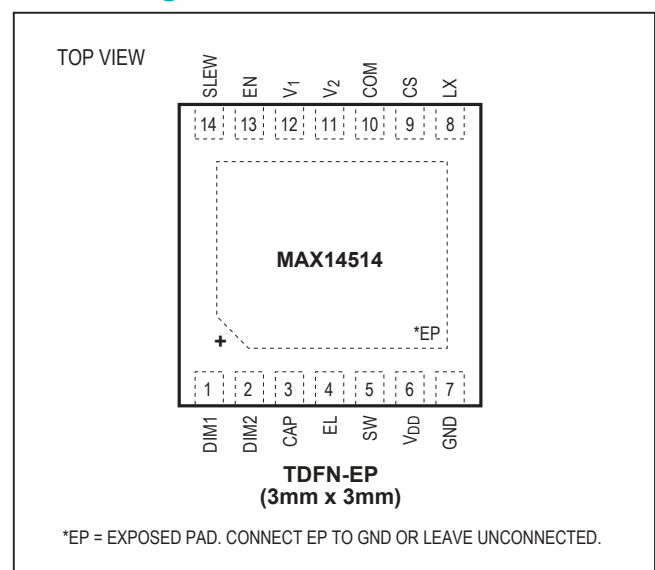

Typical Application Circuit

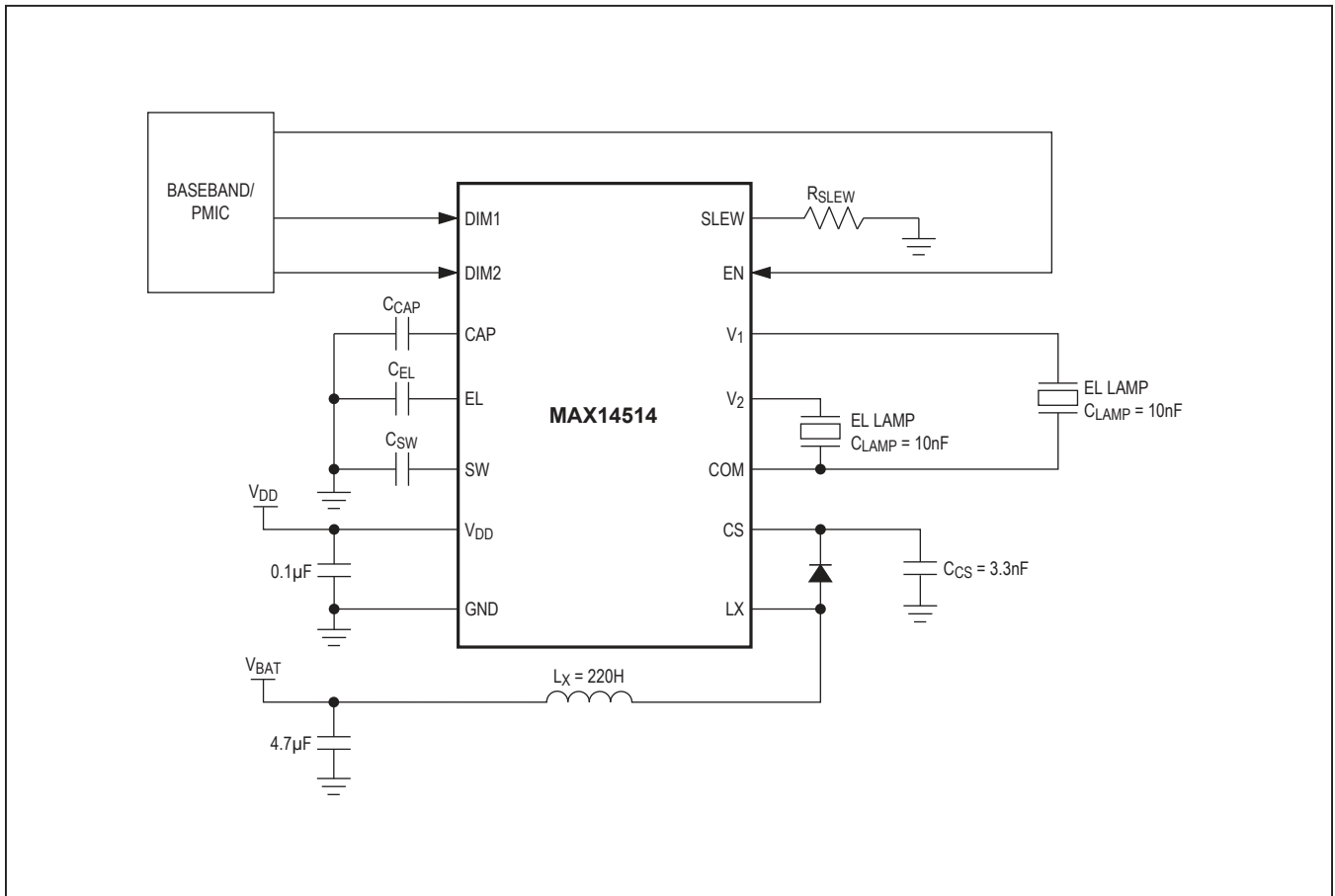

Absolute Maximum Ratings

(Voltages referenced to GND.)

V _{DD}	-0.3V to +6.0V
CS, LX.....	-0.3V to +160V
V ₁ , V ₂ , COM.....	-0.3V to (V _{CS} + 0.3V)
SW, EL, DIM_, SLEW, CAP, EN.....	-0.3V to (V _{DD} + 0.3V)
Continuous Power Dissipation (T _A = +70°C)	
14-Pin TDFN (derate 24.4mW/°C above +70°C)	1951mW
Junction-to-Case Thermal Resistance (θ _{JC}) (Note 1)	
14-Pin TDFN.....	8°C/W

Junction-to-Ambient Thermal Resistance (θ_{JA}) (Note 1)

14-Pin TDFN.....	41°C/W
Operating Temperature Range.....	-40°C to +85°C
Junction Temperature.....	+150°C
Storage Temperature Range.....	-65°C to +150°C
Lead Temperature (soldering, 10s)	+300°C

Note 1: Package thermal resistances were obtained using the method described in JEDEC specification JESD51-7, using a four-layer board. For detailed information on package thermal considerations, refer to www.maximintegrated.com/thermal-tutorial.

Stresses beyond those listed under "Absolute Maximum Ratings" may cause permanent damage to the device. These are stress ratings only, and functional operation of the device at these or any other conditions beyond those indicated in the operational sections of the specifications is not implied. Exposure to absolute maximum rating conditions for extended periods may affect device reliability.

Electrical Characteristics

(V_{DD} = +2.7V to +5.5V, C_{LAMP_TOTAL} = 10nF, C_{CS} = 3.3nF, L_X = 220µH (I_{SAT} = 170mA, R_S = 5.5Ω), T_A = -40°C to +85°C, unless otherwise noted. Typical values are at V_{DD} = +3.0V, T_A = +25°C.) (Note 2)

PARAMETER	SYMBOL	CONDITIONS	MIN	TYP	MAX	UNITS	
Input Supply Voltage	V _{DD}		2.7		5.5	V	
Input Supply Current	I _{IN}	R _{SLEW} = 375kΩ, F _{EL} = 200Hz, (V ₁ , V ₂) - V _{COM} = 300V _{P-P}			700	µA	
Shutdown Supply Current	I _{SHDN}	EN = GND		40	150	nA	
		T _A = +25°C T _A = -40°C to +85°C			400		
Shutdown Inductor Supply Current	I _{LX_SHDN}	EN = GND, LX = V _{DD} , CS = V _{DD}			1.5	µA	
Undervoltage Lockout	V _{UV}	V _{DD} falling	1.8	2.1	2.3	V	
Undervoltage Lockout Hysteresis	V _{UV_HYST}			125		mV	
EL OUTPUTS (V₁, V₂, COM)							
Peak-to-Peak Output Voltage	V ₋ - V _{COM}	V _{DD} = +3V	V _{DIM} = +0.5V	105	130	162	V
			V _{DIM} = +1V	210	260	310	
			V _{DIM} = +1.3V	250	300	350	
V ₁ , V ₂ High-Side Switch On- Resistance	R _{ONHS_VN}	I _{SOURCE} = 1mA		1.5	3.0	kΩ	
V ₁ , V ₂ Low-Side Switch On- Resistance	R _{ONLS_VN}	I _{SINK} = 1mA		0.7	2.0	kΩ	
COM High-Side Switch On- Resistance	R _{ONHS_COM}	I _{SOURCE} = 1mA		0.7	1.5	kΩ	
COM Low-Side Switch On- Resistance	R _{ONLS_COM}	I _{SINK} = 1mA		0.4	1.0	kΩ	
High-Side Switch Off-Leakage	R _{ONHS_LEAK}	V ₁ , V ₂ , V _{COM} = 0, V _{CS} = 150V	-3		+3	µA	
Low-Side Switch Off-Leakage	R _{ONLS_LEAK}	V ₁ , V ₂ , V _{COM} = 150V, V _{CS} = 150V	-3		+3	µA	
EL Lamp Switching Frequency	f _{EL}	C _{EL} = 872pF, R _{SLEW} = 375kΩ	210	250	290	Hz	
ESD Protection (COM, V ₁ , V ₂ Only)		Human Body Model		±15		kV	
		IEC 61000-4-2 Contact Discharge		±4			
		IEC 61000-4-2 Air-Gap Discharge		±4			

Electrical Characteristics (continued)

($V_{DD} = +2.7V$ to $+5.5V$, $C_{LAMP_TOTAL} = 10nF$, $C_{CS} = 3.3nF$, $L_X = 220\mu H$ ($I_{SAT} = 170mA$, $R_S = 5.5\Omega$), $T_A = -40^\circ C$ to $+85^\circ C$, unless otherwise noted. Typical values are at $V_{DD} = +3.0V$, $T_A = +25^\circ C$.) (Note 2)

PARAMETER	SYMBOL	CONDITIONS	MIN	TYP	MAX	UNITS	
BOOST CONVERTER							
Output Regulation Voltage	V_{CS}	$V_{DD} = +3V$	$V_{DIM_} = +0.5V$	52	65	81	V
			$V_{DIM_} = +1V$	105	130	155	
			$V_{DIM_} = +1.3V$	125	150	175	
Boost Switching Frequency	f_{SW}	$C_{SW} = 96pF$, $R_{SLEW} = 375k\Omega$	80	100	120	kHz	
Switch On-Resistance	R_{LX}	$I_{SINK} = 25mA$, $V_{DD} = +3V$			20	Ω	
LX Leakage Current	I_{LX}	$V_{LX} = +150V$	-1		+1	μA	
CS Input Current	I_{CS}	No load, $V_{CS} = +150V$, $V_{EN} = 0$, $V_{DIM_} = 0$			80	μA	
CONTROL INPUT (SW)							
Input-Voltage High Threshold	V_{IH_CSW}	$R_{SLEW} = 375k\Omega$	0.9	0.98	1.06	V	
Input-Voltage Low Threshold	V_{IL_CSW}	$R_{SLEW} = 375k\Omega$	0.43	0.49	0.55	V	
Input Low Current	I_{IL_CSW}	$R_{SLEW} = 375k\Omega$, $V_{CS} = +78V$, $C_{EL} = V_{DD}$, $V_{DIM_} = V_{DD}$	43		79	μA	
Input High Current	I_{IH_CSW}	$R_{SLEW} = 375k\Omega$, $V_{CS} = +78V$, $C_{EL} = V_{DD}$, $V_{DIM_} = V_{DD}$	5		7.5	μA	
CONTROL INPUT (EL)							
Input-Voltage High Threshold	V_{IH_CEL}	$R_{SLEW} = 375k\Omega$	1.08		1.32	V	
Input-Voltage Low Threshold	V_{IL_CEL}	$R_{SLEW} = 375k\Omega$	0.22		0.39	V	
Input Low Current	I_{IL_CEL}	$R_{SLEW} = 375k\Omega$	1.3		1.88	μA	
Input High Current	I_{IH_CEL}	$R_{SLEW} = 375k\Omega$	1.3		1.88	μA	
CONTROL INPUT (CAP)							
CAP Switching Frequency	f_{CAP}	$R_{SLEW} = 375k\Omega$, $C_{CAP} = 1.25nF$	180	300	410	Hz	
Slow Turn-On Time	t_{SLOW_ON}	$R_{SLEW} = 375k\Omega$, $C_{CAP} = 1.25nF$		0.3		s	
Fast Turn-On CAP Threshold	V_{FAST_CAP}	$R_{SLEW} = 375k\Omega$	$V_{DD}-0.35$			V	
Nonfast Turn-On CAP Threshold	$V_{NON-FAST_CAP}$	$R_{SLEW} = 375k\Omega$			1.4	V	
Input Leakage Current	I_{IH_CAP}	CAP = V_{DD} , $R_{SLEW} = 375k\Omega$	Normal operation	0.3	1	μA	
			Shutdown mode	-100	100	nA	
CONTROL INPUT (SLEW)							
Force Voltage	V_{FORCE}	$R_{SLEW} = 375k\Omega$	0.9	0.98	1.05	V	
High-Voltage Output Slew Rate		$R_{SLEW} = 375k\Omega$		32		V/100 μs	
CONTROL INPUTS (DIM1, DIM2)							
Input High Voltage	V_{IH_DIM}	Max output voltage	1.3			V	
Input Low Voltage	V_{IL_DIM}	Min output voltage			0.15	V	
Input Low Current	I_{IL_DIM}	$V_{DIM_} = 0$, $R_{SLEW} = 375k\Omega$	2.2	2.6	3.0	μA	
Input High Current	I_{IH_DIM}	$V_{DIM_} = V_{DD}$	-1		+1	μA	
PWM Frequency Range				0.2 to 1		MHz	

Electrical Characteristics (continued)

($V_{DD} = +2.7V$ to $+5.5V$, $C_{LAMP_TOTAL} = 10nF$, $C_{CS} = 3.3nF$, $L_X = 220\mu H$ ($I_{SAT} = 170mA$, $R_S = 5.5\Omega$), $T_A = -40^\circ C$ to $+85^\circ C$, unless otherwise noted. Typical values are at $V_{DD} = +3.0V$, $T_A = +25^\circ C$.) (Note 2)

PARAMETER	SYMBOL	CONDITIONS	MIN	TYP	MAX	UNITS
Low-Peak Detector Threshold	V_{LPD}		0.13		0.35	V
Low-Peak Detector Hysteresis	V_{LPD_HYST}			100		mV
CONTROL INPUT (EN)						
Input Logic-High Voltage	V_{IH_EN}		1.4			V
Input Logic-Low Voltage	V_{IL_EN}				0.3	V
THERMAL SHUTDOWN						
Thermal Shutdown				158		$^\circ C$
Thermal Shutdown Hysteresis				8		$^\circ C$

Note 2: All devices are 100% production tested at $T_A = +25^\circ C$. All temperature limits are guaranteed by design.

Typical Operating Characteristics

($V_{DD} = +3.6V$, $T_A = +25^\circ C$, unless otherwise noted.)

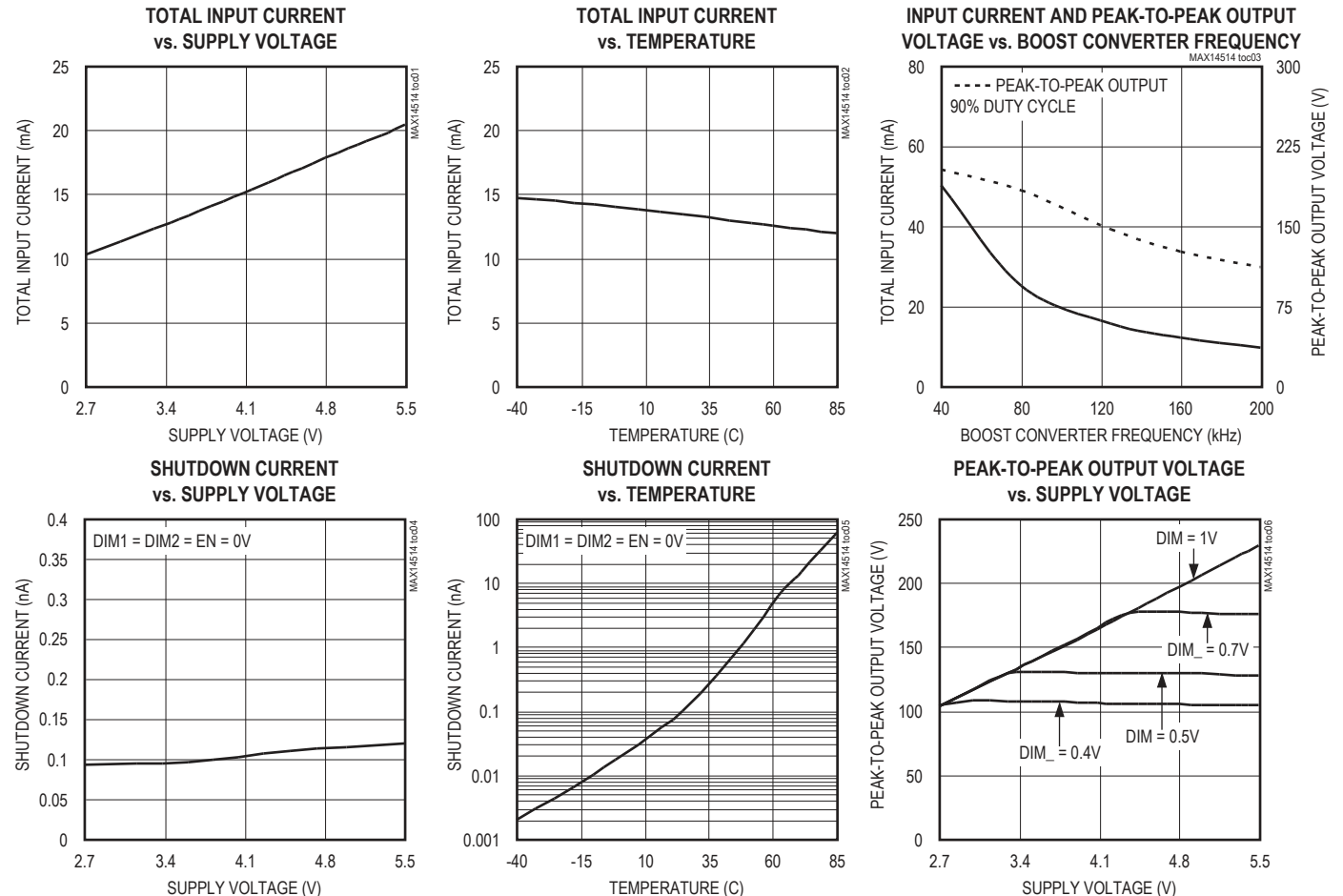

Typical Operating Characteristics (continued)

($V_{DD} = +3.6V$, $T_A = +25^\circ C$, unless otherwise noted.)

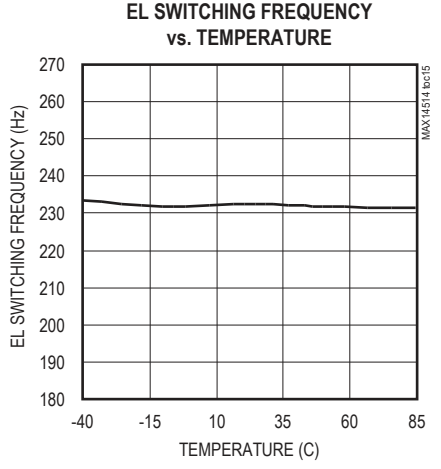
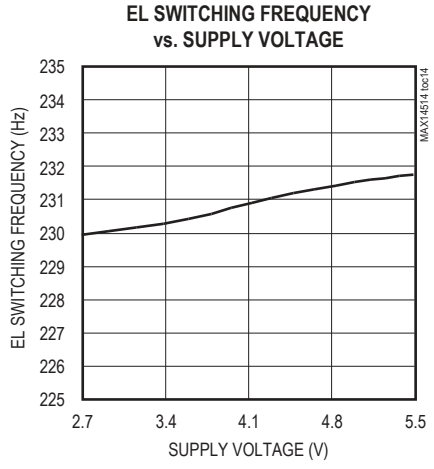
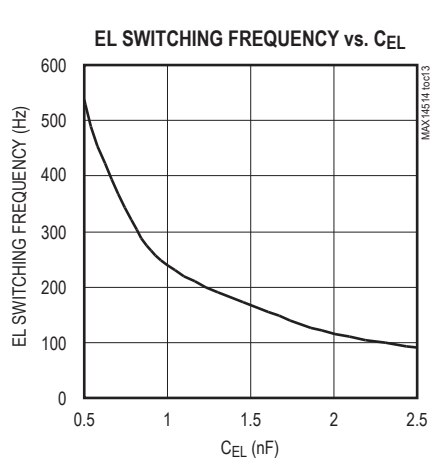
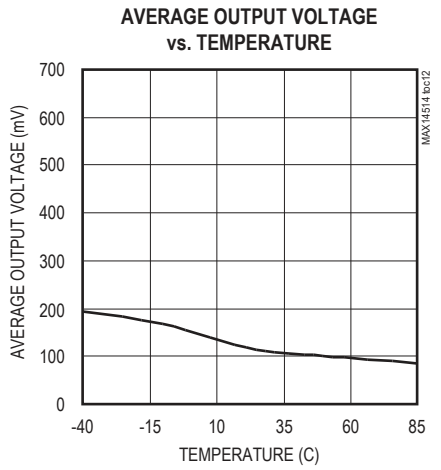
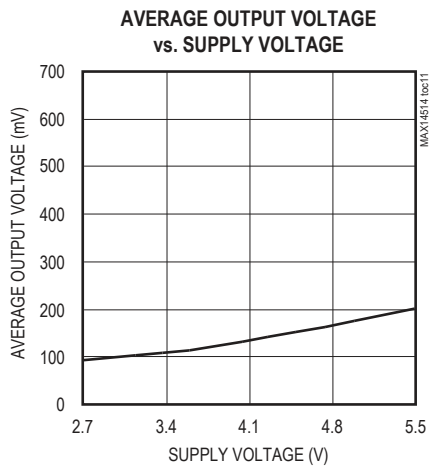
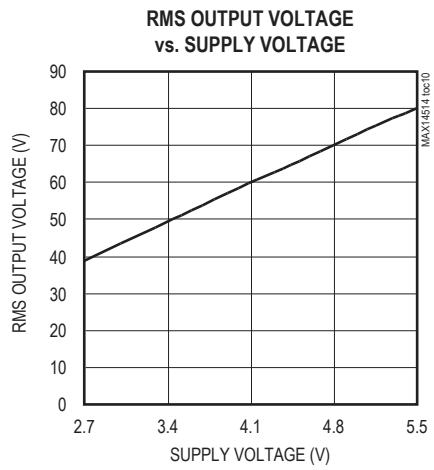
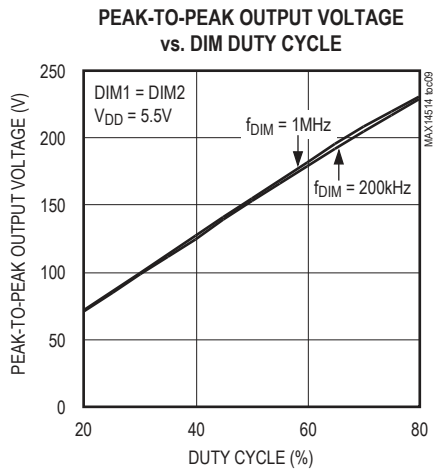
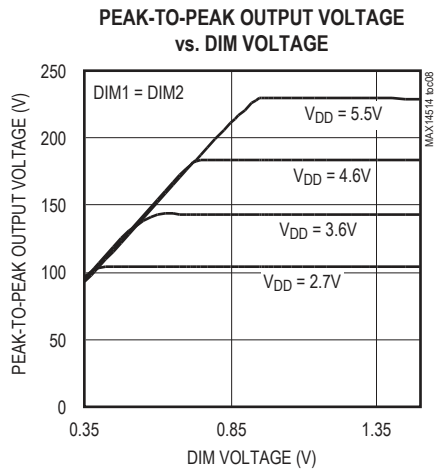
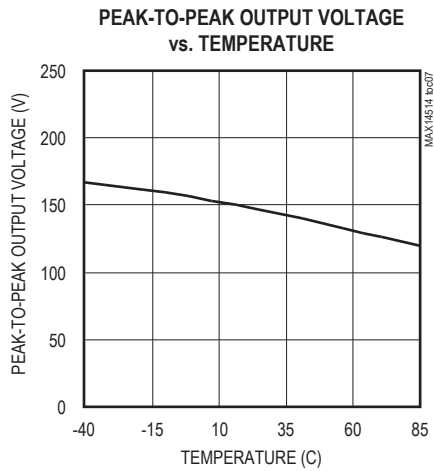

Typical Operating Characteristics (continued)

($V_{DD} = +3.6V$, $T_A = +25^\circ C$, unless otherwise noted.)

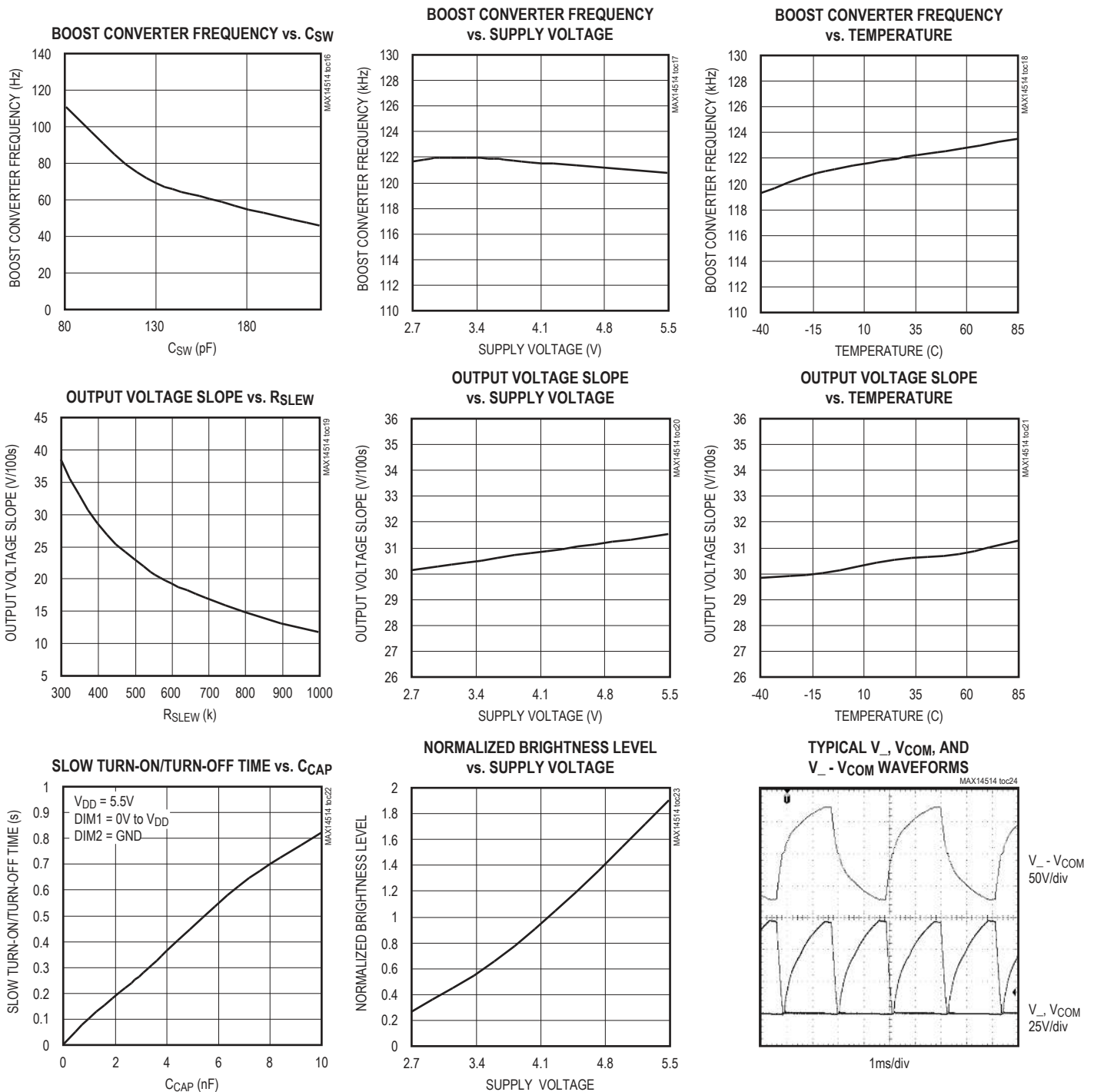

Pin Description

PIN	NAME	FUNCTION
1	DIM1	High-Voltage Output 1 Dimming Control. Apply a PWM signal, DC analog control signal, or connect a resistor from DIM1 to GND to adjust V_1 peak-to-peak output voltage. Drive DIM1 high or leave DIM1 unconnected to set V_1 to full brightness level.
2	DIM2	High-Voltage Output 2 Dimming Control. Apply a PWM signal, DC analog control signal, or connect a resistor from DIM2 to GND to adjust V_2 peak-to-peak output voltage. Drive DIM2 high or leave DIM2 unconnected to set V_2 to full brightness level.
3	CAP	Turn-On Time Input. For fast turn-on mode, connect CAP to V_{DD} . For slow turn-on/-off mode, connect a capacitor from CAP to GND to set the turn-on/-off time. $t_{ON/OFF} = 0.27 \times C_{CAP} \times R_{SLEW}$.
4	EL	EL Voltage Switching Frequency. Connect an external capacitor, C_{EL} , from EL to GND or drive EL with an external oscillator to set the switching frequency of the V1 and V2 high-voltage outputs. Connect EL to GND to shut off the EL oscillator.
5	SW	Boost Converter Switching Frequency. Connect an external capacitor, C_{SW} , from SW to GND or drive with an external oscillator to set the switching frequency of the boost converter. Connect SW to GND to shut off the boost oscillator. To avoid LX shorting to GND and causing an increase in internal die temperature, do not keep SW high. The MAX14514 is protected by entering a thermal-shutdown state. (See the <i>Thermal Short-Circuit Protection</i> section.)
6	V_{DD}	Input Supply Voltage
7	GND	Ground
8	LX	Internal Switching DMOS Drain Connection. Connect LX to a switching inductor and an anode of a rectifying diode.
9	CS	High-Voltage Feedback Connection. Connect CS to output of boost converter (cathode of rectifying diode).
10	COM	High-Voltage EL Panel Common Output. Connect COM to common side of EL lamp.
11	V_2	High-Voltage EL Panel Output 2. Connect V_2 to non-COM side of EL lamp 2.
12	V_1	High-Voltage EL Panel Output 1. Connect V_1 to non-COM side of EL lamp 1.
13	EN	Enable Input. Drive $EN > V_{IH_EN}$ to turn on the device. Drive $EN < V_{IL_EN}$ to turn off the device (see the <i>Shutdown</i> section).
14	SLEW	High-Voltage Slew-Rate Control. Connect an external resistor, R_{SLEW} , from SLEW to GND to set the slew rate of the high-voltage outputs V_1 and V_2 .
—	EP	Exposed Pad. Connect EP to GND.

Functional Diagram

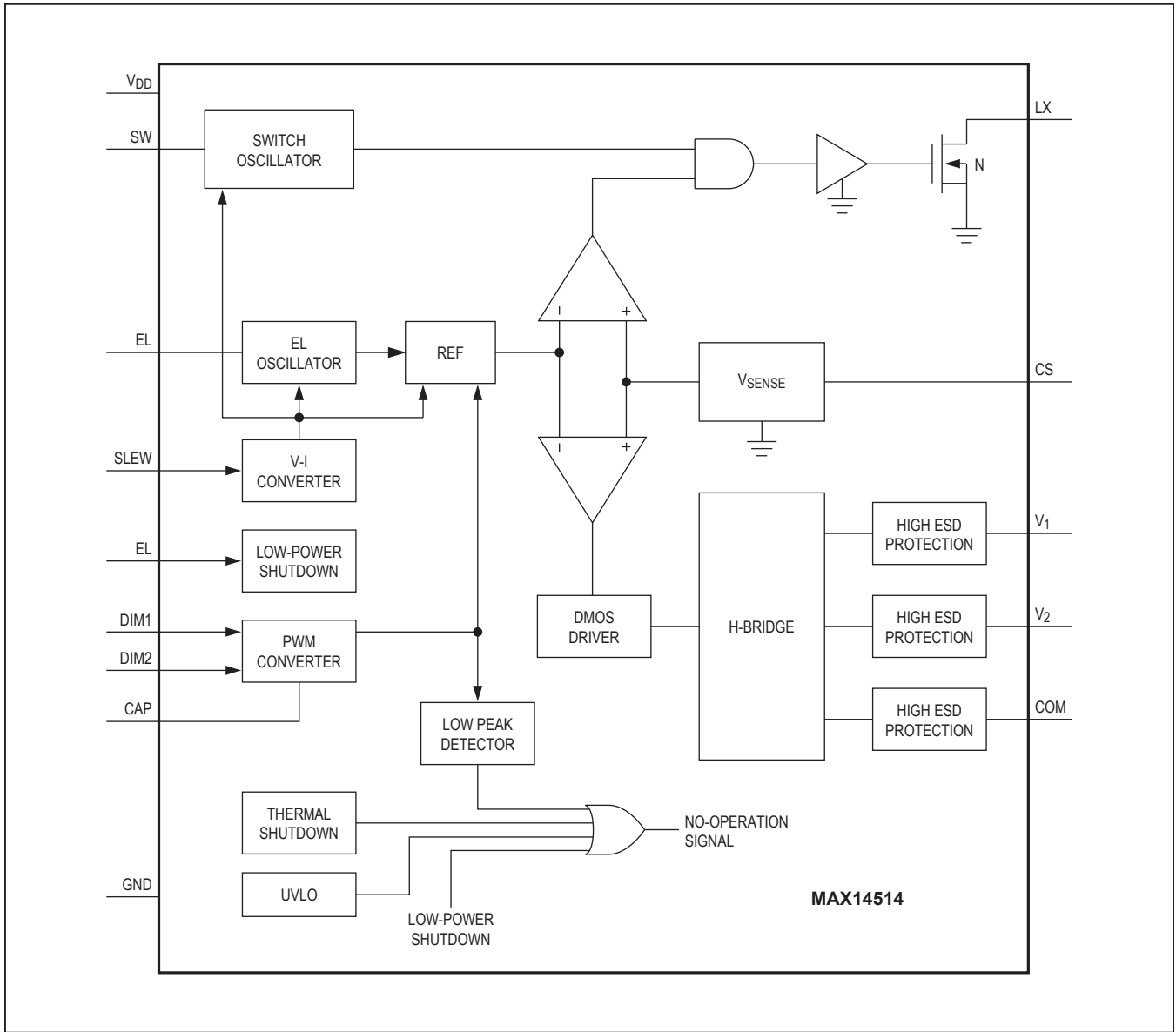

Detailed Description

The MAX14514 high-voltage DC-AC converter is designed to drive two EL lamps. The MAX14514 features a +2.7V to +5.5V input range that allows the device to accept a wide variety of voltage sources, including single-cell Li+ batteries. The lamp outputs of the device generate up to 300V_{P-P} for maximum lamp brightness. The slew rate, frequency, and peak-to-peak voltage of the MAX14514 EL lamp outputs are programmed through a combination of external components and/or logic inputs.

Output Slew Rate

The MAX14514 uses the resistor R_{SLEW} to set a reference current for the internal circuitry. The reference current directly affects the slew rate of the EL lamp output. Increasing the value of R_{SLEW} decreases the slew rate, and decreasing the value of R_{SLEW} increases the slew rate. (See the R_{SLEW} Resistor Selection section on how to select R_{SLEW}.)

Output Frequency

The MAX14514 uses an internal oscillator to set the desired output frequency. The output frequency is adjusted by either 1) the combination of a resistor from SLEW to GND and an external capacitor from the EL input to GND, or 2) by driving a clock signal directly into the EL input. (See the C_{EL} Capacitor Selection section for choosing the C_{EL} capacitor value.)

Dimming Control

The MAX14514 features dimming control inputs, DIM1 and DIM2, to control the peak-to-peak voltages on lamp outputs V₁, V₂, and COM. DIM₁ is controlled by either a DC voltage, a PWM signal, or a resistor from DIM₁ to GND. (See the R_{DIM} Resistor Selection section.)

Applying a DC voltage to DIM₁ ranging from V_{L_{PD}} to V_{I_H}_{DIM₁} linearly varies the corresponding output voltage from 130V to 300V. Increasing the voltage on DIM₁ increases the peak-to-peak output, and decreasing the voltage on DIM₁ decreases the peak-to-peak output voltage. Note that when V_{DIM₁} goes below V_{I_L}_{DIM₁}, the corresponding output turns off.

DIM₁ features an internal lowpass filter to allow a PWM signal to control the output voltage. Voltages on DIM₁ are internally level translated down to V_{I_H}_{DIM₁}, so that the equivalent voltage on DIM₁ is (%duty cycle) x V_{I_H}_{DIM₁}. The DIM₁ inputs accept the 200kHz to 1MHz frequency range. Note that for PWM signals, the logic voltage applied to DIM₁ must be greater than or equal to V_{I_H}_{DIM₁}.

The peak-to-peak EL lamp output voltage is related to V_{DIM₁} (for V_{DIM₁} > V_{I_L}_{DIM₁}) or PWM duty cycle by the following equation:

$$V_{-} - V_{COM} = 260 \times (V_{DIM_{1}}) = 260 \times (\%duty\ cycle) \times (V_{I_{H}}_{DIM_{1}})$$

Slow Turn-On, Slow Turn-Off

The MAX14514 provides a slow turn-on and slow turn-off time feature that is enabled by connecting a capacitor from CAP to GND (see the Typical Application Circuit and the C_{CAP} Capacitor Selection section). This slow turn-on/off feature causes the peak-to-peak voltage of the EL outputs to slowly rise or fall any time the outputs are enabled or disabled, either through EN or DIM₁ (see Table 1). The slow rise and fall of the peak-to-peak EL output voltage creates a soft fade-on and fade-off of the EL lamp, rather than an abrupt change in brightness. To disable the slow turn-on/turn-off feature, connect CAP to V_{DD}.

Table 1. Slow Turn-On, Slow Turn-Off

LOGIC INPUT			EL OUTPUTS*	
EN	DIM1	DIM2	V ₁	V ₂
1 ≥ 0	1	1	Slow Turn-Off	Slow Turn-Off
0 ≥ 1	1	1	Slow Turn-On	Slow Turn-On
1	1 ≥ 0	X	Slow Turn-Off	X
1	0 ≥ 1	X	Slow Turn-On	X
1	X	1 ≥ 0	X	Slow Turn-Off
1	X	0 ≥ 1	X	Slow Turn-On

*With capacitor from CAP to GND (CAP is not connected to VDD).
X = Don't Care.

Boost Converter

The MAX14514 boost converter consists of an external inductor from V_{DD} to the LX input, an internal DMOS switch, an external diode from LX to the CS output, an external capacitor from the CS output to GND, and the EL lamps, CLAMP1 and CLAMP2, connected to the EL lamp outputs. When the DMOS switch is turned on, LX is connected to GND, and the inductor is charged. When the DMOS switch is turned off, the energy stored in the inductor is transferred to the capacitor C_{CS} and the EL lamps.

Note: Keeping SW high shorts LX to GND and causes the internal die temperature to increase. The MAX14514 is protected by entering a thermal-shutdown state (see the Thermal Short-Circuit Protection section).

The MAX14514 boost converter frequency uses an internal switch oscillator to set the desired frequency of the boost converter. The boost converter frequency is adjusted by either 1) the combination of a resistor from SLEW to GND and an external capacitor from SW to GND, or 2) by driving a PWM signal directly into the SW input. When SW is driven with an external PWM signal at a suggested 90% duty cycle, the boost converter frequency is changed to the frequency of the external PWM signal. (See the *C_{SW} Capacitor Selection* section for choosing the C_{SW} capacitor value.)

Shutdown

The MAX14514 features a shutdown mode to disable the device and reduce supply current. Entering and exiting shutdown mode depends on if slow turn-on/turn-off is enabled or disabled.

When slow turn-on/turn-off is enabled, shut down the device by driving EN low. Enable the device by driving EN high.

When slow turn-on/turn-off is disabled, shut down the device by driving EN low and both DIM1 and DIM2 below V_{IL_DIM_}. Enable the device by driving EN high and either DIM1 or DIM2 above V_{LDPD_}.

Undervoltage Lockout (UVLO)

The MAX14514 has a UVLO threshold of +2.1V (typ). When V_{DD} falls below this threshold, the device enters a nonoperative mode.

Thermal Short-Circuit Protection

The MAX14514 enters a nonoperative mode if the internal die temperature of the device reaches or exceeds +158°C (typ). The device turns back on when the internal die temperature cools to +150°C (typ).

±15kV ESD Protection

As with all Maxim devices, ESD-protection structures are incorporated on all pins to protect against electrostatic discharges encountered during handling and assembly. The EL lamp driver outputs of the MAX14514 (V₁, V₂, and COM) have extra protection against static electricity. Maxim's engineers have developed state-of-the-art structures to protect these pins against ESD of ±15kV

without damage. The ESD structures withstand high ESD in all states: normal operation, shutdown, and powered down. After an ESD event, the MAX14514 keeps working without latchup or damage. ESD protection can be tested in various ways. The transmitter EL lamp outputs of the MAX14514 are characterized for protection to the following limits:

- ±15kV using the Human Body Model
- ±4kV IEC 61000-4-2 Contact Discharge
- ±4kV IEC 61000-4-2 Air-Gap Discharge

ESD Test Conditions

ESD performance depends on a variety of conditions. Contact Maxim for a reliability report that documents test setup, test methodology, and test results.

Human Body Model

Figure 1a shows the Human Body Model, and Figure 1b shows the current waveform it generates when discharged into a low impedance. This model consists of a 100pF capacitor charged to the ESD voltage of interest, which is then discharged into the test device through a 1.5kΩ resistor.

IEC 61000-4-2

The IEC 61000-4-2 standard covers ESD testing and performance of finished equipment. However, it does not specifically refer to integrated circuits. The MAX14514 assists in designing equipment to meet IEC 61000-4-2 without the need for additional ESD-protection components.

The major difference between tests done using the Human Body Model and IEC 61000-4-2 is higher peak current in IEC 61000-4-2 because series resistance is lower in the IEC 61000-4-2 model. Hence, the ESD withstand voltage measured to IEC 61000-4-2 is generally lower than that measured using the Human Body Model. Figure 1c shows the IEC 61000-4-2 model, and Figure 1d shows the current waveform for IEC 61000-4-2 ESD Contact Discharge test.

The air-gap test involves approaching the device with a charged probe. The contact discharge method connects the probe to the device before the probe is energized.

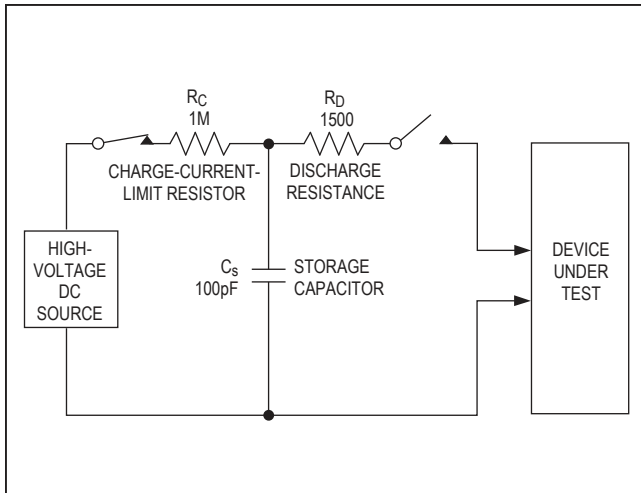

Figure 1a. Human Body ESD Test Model

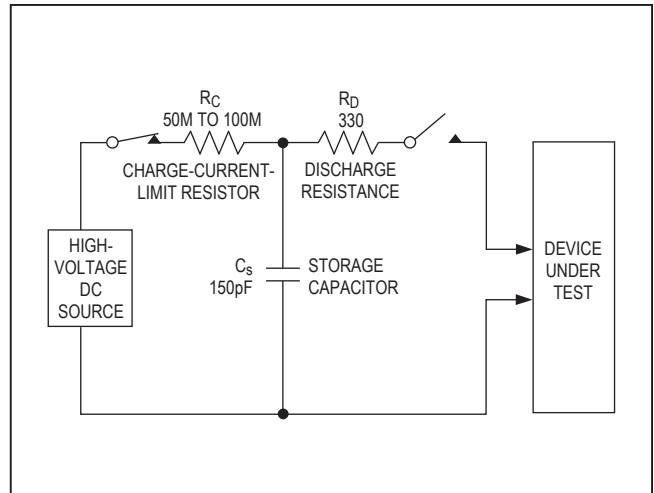

Figure 1c. IEC 61000-4-2 ESD Test Model

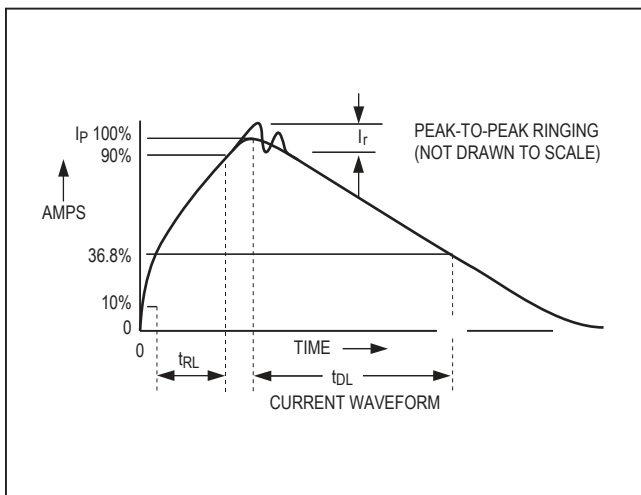

Figure 1b. Human Body Current Waveform

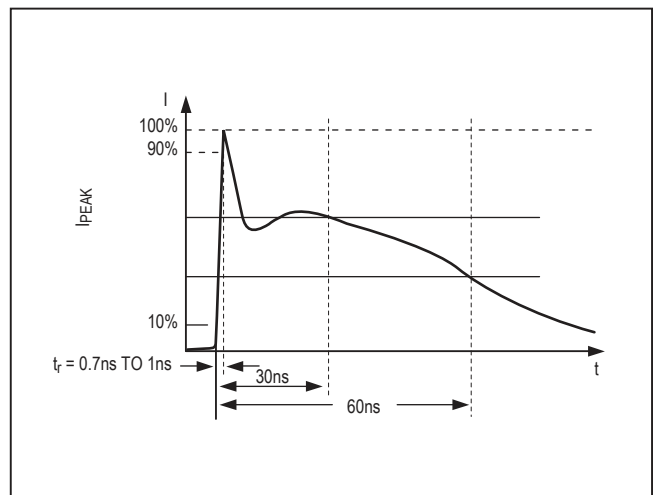

Figure 1d. IEC 61000-4-2 ESD Generator Current Waveform

Table 2. Inductor Vendors

INDUCTOR VALUE (μH)	VENDOR	WEBSITE	PART
220	TOKO	www.tokoam.com	D312C 1001BS-221M
330	Coilcraft	www.coilcraft.com	DO1608C-334ML
470	Coilcraft	www.coilcraft.com	DO1608C-474ML
220	Coilcraft	www.coilcraft.com	LPS4018-224ML
330	Coilcraft	www.coilcraft.com	LPS4018-334ML
470	Coilcraft	www.coilcraft.com	LPS4018-474ML
220	Cooper Bussmann	www.cooperet.com	SDH3812-221-R
220	Cooper Bussmann	www.cooperet.com	SD3110-221-R

Design Procedure

LX Inductor Selection

The recommended inductor values are 220 μ H/330 μ H. For most applications, series resistance (DCR) should be below 8 Ω for reasonable efficiency. Do not exceed the inductor's saturation current.

RSLEW Resistor Selection

To help reduce audible noise emission by the EL lamps, the MAX14514 features a slew-rate control input (SLEW) that allows the user to set the slew rate of high-voltage outputs, V₁, V₂, and COM, by connecting a resistor, RSLEW, from the SLEW input to GND. Decreasing the value of RSLEW increases the slew rate at the EL lamp output. Increasing the value of RSLEW decreases the slew rate at the EL lamp outputs. The output slew rate is related to RSLEW by the following equation:

$$\text{SlewRate}(V/100\mu s) = 12/RSLEW(M\Omega)$$

The ideal value for a given design varies depending on lamp size and mechanical enclosure. Typically, the best slew rate for minimizing audible noise is between 10V/100 μ s and 20V/100 μ s. This results in RSLEW values ranging from 1.2M Ω to 600k Ω . For example, if the desired slew rate is 20(V/100 μ s), this leads to an RSLEW value of 12/20(V/100 μ s) = 600k Ω .

Note: Connecting RSLEW to GND does not damage the device. However, for the device to operate correctly, RSLEW should be in the 100k Ω to 2.2M Ω range. RSLEW also affects the frequency of the boost converter (see the *C_{SW} Capacitor Selection* section), the frequency of the EL lamp (see the *C_{EL} Capacitor Selection* section), and the peak-to-peak voltage of the EL lamp.

CCAP Capacitor Selection

The MAX14514 provides a slow turn-on/-off feature that is enabled by connecting a capacitor from CAP to GND. For fast turn-on/-off, connect CAP to V_{DD}. Slow turn-on/-offtime is related by the following equation:

$$t_{ON/OFF} = 0.27 \times C_{CAP} \times RSLEW$$

R_{DIM} Resistor Selection

The MAX14514 features dimming control inputs, DIM1 and DIM2, to control the peak-to-peak voltages on the lamp outputs V₁, V₂, and COM. DIM_ is controlled by a PWM signal, DC voltage, or by a resistor connected from DIM_ to GND. When using a resistor, the output voltage is related by the following equation:

$$V_- - V_{COM} = 260 \times R_{DIM}/RSLEW$$

C_{CS} Capacitor Selection

C_{CS} is the output of the boost converter and provides the high-voltage source for the EL lamp. Connect a 3.3nF capacitor from CS to GND and place as close to the CS input as possible. When using an inductor value larger than 220 μ H, it may be necessary to increase C_{CS}. For a 470 μ H inductor and C_{LAMP_TOTAL} = 20nF, a C_{CS} ranging from 3.3nF to 6.8nF is recommended.

C_{EL} Capacitor Selection

The MAX14514 EL lamp output frequency is set by connecting a capacitor from the EL input to GND together with a resistor from SLEW to GND or by driving the EL input with an external clock. The EL lamp output frequency is related to the C_{EL} capacitor by the following equation:

$$f_{EL} = 0.08175/(RSLEW \times C_{EL})$$

For example, an RSLEW = 375k Ω and a C_{EL} capacitor value of 872pF equals an EL lamp output frequency of f_{EL} = 250Hz.

C_{SW} Capacitor Selection

The boost converter switching frequency is set by connecting a capacitor from the SW input to GND, together with the resistance from the SLEW input to GND, or driving the SW input with an external clock (0 to +1.5V). The switching frequency of the boost converter is related to the capacitor from SW to GND by the following equation:

$$f_{SW} = 3.6/(RSLEW \times C_{SW})$$

Connect the SW input to GND to turn the switch oscillator of the boost converter off. Although the optimal f_{SW} depends on the inductor value, the suggested f_{SW} range is 20kHz to 150kHz.

Note: Driving SW with a logic-high causes LX to be driven to GND. Keeping SW high shorts LX to GND, causing the internal die temperature to increase. The MAX14514 is protected by entering a thermal-shutdown state. (See the *Thermal Short-Circuit Protection* section.)

Bypass Capacitor Selection

Bypass V_{DD} with a 0.1 μ F ceramic capacitor as close to the IC as possible and a 4.7 μ F ceramic capacitor as close to the inductor as possible.

Diode Selection

Connect a diode, D1, from the LX node to CS to rectify the boost voltage on CS. The diode should be a fast-recovery diode that is tolerant to +150V.

EL Lamp Selection

EL lamps have a capacitance of approximately 2.5nF to 3.5nF per square inch. The MAX14514 effectively charges capacitance ranging from 2nF to 20nF.

Applications Information

PCB Layout

Keep PCB traces as short as possible. Ensure that bypass capacitors are as close to the device as possible. Use large ground planes where possible.

Chip Information

PROCESS: BiCMOS-DMOS

Package Information

For the latest package outline information and land patterns (footprints), go to www.maximintegrated.com/packages. Note that a "+", "#", or "-" in the package code indicates RoHS status only. Package drawings may show a different suffix character, but the drawing pertains to the package regardless of RoHS status.

PACKAGE TYPE	PACKAGE CODE	DOCUMENT NO.
14 TDFN-EP	T1433-2	21-0137

Revision History

REVISION NUMBER	REVISION DATE	DESCRIPTION	PAGES CHANGED
0	2/09	Initial release	—
1	4/14	Removed automotive reference from <i>Applications</i> section	1
2	9/18	Updated <i>Electrical Characteristics</i> table	3, 4

For pricing, delivery, and ordering information, please visit Maxim Integrated's online storefront at <https://www.maximintegrated.com/en/storefront/storefront.html>.

Maxim Integrated cannot assume responsibility for use of any circuitry other than circuitry entirely embodied in a Maxim Integrated product. No circuit patent licenses are implied. Maxim Integrated reserves the right to change the circuitry and specifications without notice at any time. The parametric values (min and max limits) shown in the *Electrical Characteristics* table are guaranteed. Other parametric values quoted in this data sheet are provided for guidance.