



## SPECIFICATION

**CUSTOMER** : MIKROELEKTRONIKA

**MODULE NO.:** WDG0151-TMI-V#N00

<b>APPROVED BY:</b>  ( FOR CUSTOMER USE ONLY )	<b>PCB VERSION:</b>	<b>DATA:</b>
--	---------------------	--------------

SALES BY	APPROVED BY	CHECKED BY	PREPARED BY

VERSION	DATE	REVISED PAGE NO.	SUMMARY
0	2009/11/10		First issue

MODLE NO :

**RECORDS OF REVISION**

**DOC. FIRST ISSUE**

VERSION	DATE	REVISED PAGE NO.	SUMMARY
0	2009/11/10		First issue

# **Contents**

1. Module classification information
2. Precautions in Use of LCM
3. General Specification
4. Absolute Maximum Ratings
5. Electrical Characteristics
6. Optical Characteristics
7. Interface Pin Function
8. Counter Drawing & Block Diagram
9. Timing Characteristics
10. Display Control Instruction
11. Detailed Explanation
12. Reliability
13. Backlight Information
14. Inspection specification
15. Material List of Components for RoHs

# 1. Module Classification Information

W D G    0151 -    T M I -    V# N00  
 ① ② ③      ④                ⑤ ⑥ ⑦                          ⑧

- ① Brand : WINSTAR DISPLAY CORPORATION
- ② Custom : D
- ③ Display Type : H→ Character Type ; G→ Graphic Type N → LCD Display
- ④ Model serials no.0000 - ZZZZ
- ⑤ Backlight Type :
 

N→ Without backlight	P→ LED, Blue
B→ EL, Blue green	A→ LED, Amber
D→ EL, Green	R→ LED, Red
W→ EL, White	O→ LED, Orange
F→ CCFL, White	G→ LED, Green
Y→ LED, Yellow Green	T→ LED, White
- ⑥ LCD Mode :
 

B→ TN Positive, Gray	T→ FSTN Negative
N→ TN Negative,	
G→ STN Positive, Gray	
Y→ STN Positive, Yellow Green	
M→ STN Negative, Blue	
F→ FSTN Positive	
- ⑦ LCD Polarizer
 

A→ Reflective, N.T, 6:00	H→ Transflective, W.T,6:00
D→ Reflective, N.T, 12:00	K→ Transflective, W.T,12:00
G→ Reflective, W. T, 6:00	C→ Transmissive, N.T,6:00
J→ Reflective, W. T, 12:00	F→ Transmissive, N.T,12:00
B→ Transflective, N.T,6:00	I→ Transmissive, W. T, 6:00
E→ Transflective, N.T.12:00	L→ Transmissive, W.T,12:00
- ⑧ Special Code
 

V: Build in Negative Voltage    N: IC NT7107, NT7108C

# : Fit in with the ROHS Directions and regulations;

0:Sales code    0:Version

## 2.Precautions in Use of LCD Module

- (1) Avoid applying excessive shocks to the module or making any alterations or modifications to it.
- (2) Don't make extra holes on the printed circuit board, modify its shape or change the components of LCD Module.
- (3) Don't disassemble the LCM.
- (4) Don't operate it above the absolute maximum rating.
- (5) Don't drop, bend or twist LCM.
- (6) Soldering: only to the I/O terminals.
- (7) Storage: please storage in anti-static electricity container and clean environment.
- (8). Winstar have the right to change the passive components
- (9). Winstar have the right to change the PCB Rev.

## 3.General Specification

ITEM	STANDARD VALUE	UNIT
Number of dots	128 ×64	dots
Outline dimension	78.0 (W) ×70.0 (H) ×14.3 (T)	mm
View area	62.0(W) ×44.0(H)	mm
Active area	56.3(W) ×38.38(H)	mm
Dot size	0.42(W) ×0.58(H)	mm
Dot pitch	0.44(W) ×0.60(H)	mm
LCD type	STN Negative, Blue, Transmissive (In LCD production, It will occur slightly color difference. We can only guarantee the same color in the same batch.)	
View direction	6 o'clock	
Backlight	LED , White	

## 4. Absolute Maximum Ratings

ITEM	SYMBOL	MIN.	TYP.	MAX.	UNIT
Operating Temperature	$T_{OP}$	-20	-	+70	°C
Storage Temperature	$T_{ST}$	-30	-	+80	°C
Input Voltage	$V_I$	0	-	$V_{DD}$	V
Supply Voltage For Logic	$V_{DD}-V_{SS}$	0	-	6.5	V
Supply Voltage For LCD	$V_{DD}-V_{LCD}$	0	-	17.0	V

## 5. Electrical Characteristics

ITEM	SYMBOL	CONDITION	MIN.	TYP.	MAX.	UNIT
Logic Voltage	$V_{DD}-V_{SS}$	-	4.5	5.0	5.5	V
Supply Voltage For LCD *Note	$V_{DD}-V_O$	$T_a=-20^{\circ}\text{C}$	-	-	-	V
		$T_a=25^{\circ}\text{C}$	7.62	8.51	9.26	V
		$T_a=+70^{\circ}\text{C}$	-	-	-	V
Input High Volt.	$V_{IH}$	-	2.0	-	$V_{DD}$	V
Input Low Volt.	$V_{IL}$	-	0	-	0.8	V
Output High Volt.	$V_{OH}$	-	2.4	-	$V_{DD}$	V
Output Low Volt.	$V_{OL}$	-	0	-	0.4	V
Supply Current	$I_{OP}$	5.0	2.8	3.1	3.4	mA

\* Note: Please design the VOP adjustment circuit on customer's main board

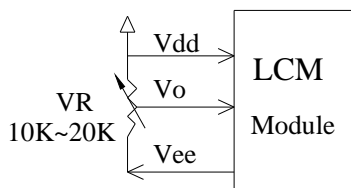

# 6. Optical Characteristics

ITEM	SYMBAL	CONDITION	MIN	TYP	MAX	UNIT
View Angle	(V) $\theta$	$CR \geq 2$	20	-	40	deg.
	(H) $\phi$	$CR \geq 2$	-30	-	30	deg.
Contrast Ratio	CR	-	-	3	-	-
Response Time	T rise	-	-	200	300	ms
	T fall	-	-	150	200	ms

## 6.1 Definitions

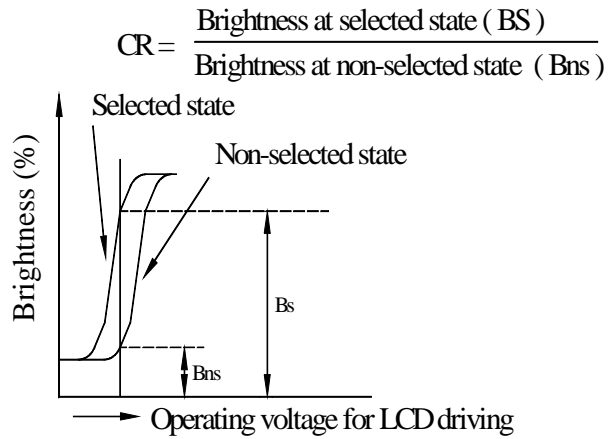
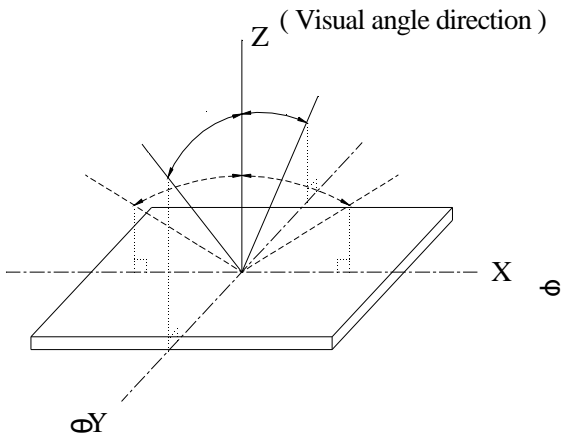

### ■ View Angles

### ■ Contrast Ratio

### ■ Response time

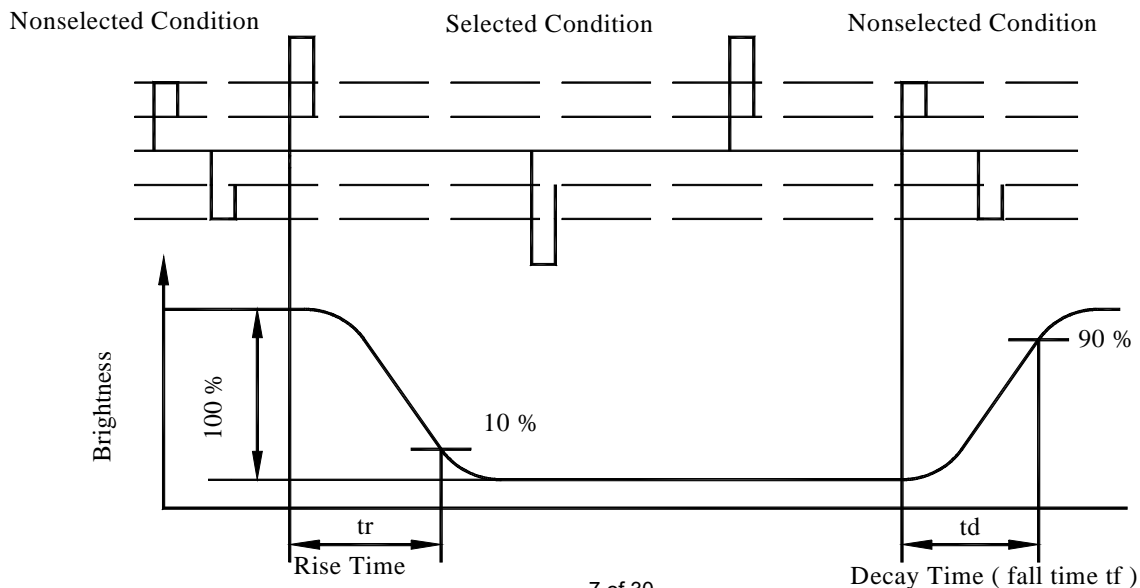

# 7.Interface Pin Function

Pin No.	Symbol	Level	Description
1	$\overline{CS1}$	L	Select Segment 1 ~ Segment 64
2	$\overline{CS2}$	L	Select Segment 65 ~ Segment128
3	V <sub>SS</sub>	0V	Ground
4	V <sub>DD</sub>	5.0V	Supply voltage for logic
5	V <sub>O</sub>	(Variable)	Operating voltage for LCD
6	D/I	H/L	H: Data , L: Instruction
7	R/W	H/L	H: Read(MPU Module) , L :Write(MPU→ Module)
8	E	H	Enable signal
9	DB0	H/L	Data bus line
10	DB1	H/L	Data bus line
11	DB2	H/L	Data bus line
12	DB3	H/L	Data bus line
13	DB4	H/L	Data bus line
14	DB5	H/L	Data bus line
15	DB6	H/L	Data bus line
16	DB7	H/L	Data bus line
17	RST	L	Reset the LCM
18	VEE		Negative Voltage Output
19	A		Power supply for B/L(+)
20	K		Power supply for B/L(-)



# 8. Counter Drawing & Block diagram

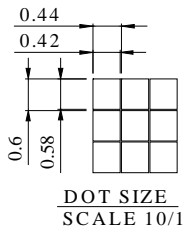
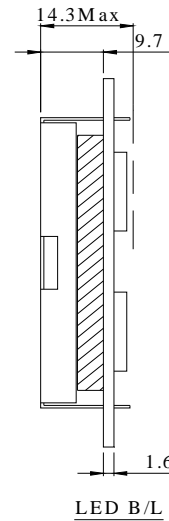
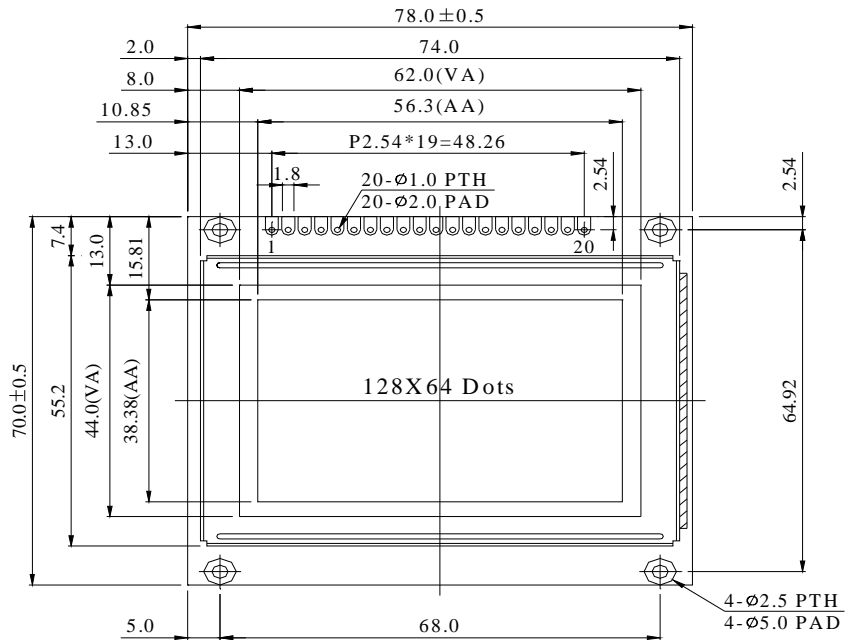

The non-specified tolerance of dimension is ±0.3mm.

PIN NO.	SYMBOL
1	$\overline{CS1}$
2	$\overline{CS2}$
3	V <sub>SS</sub>
4	V <sub>DD</sub>
5	V <sub>o</sub>
6	D/I
7	$\overline{R/W}$
8	E
9	DB0
10	DB1
11	DB2
12	DB3
13	DB4
14	DB5
15	DB6
16	DB7
17	RST
18	VEE
19	A
20	K

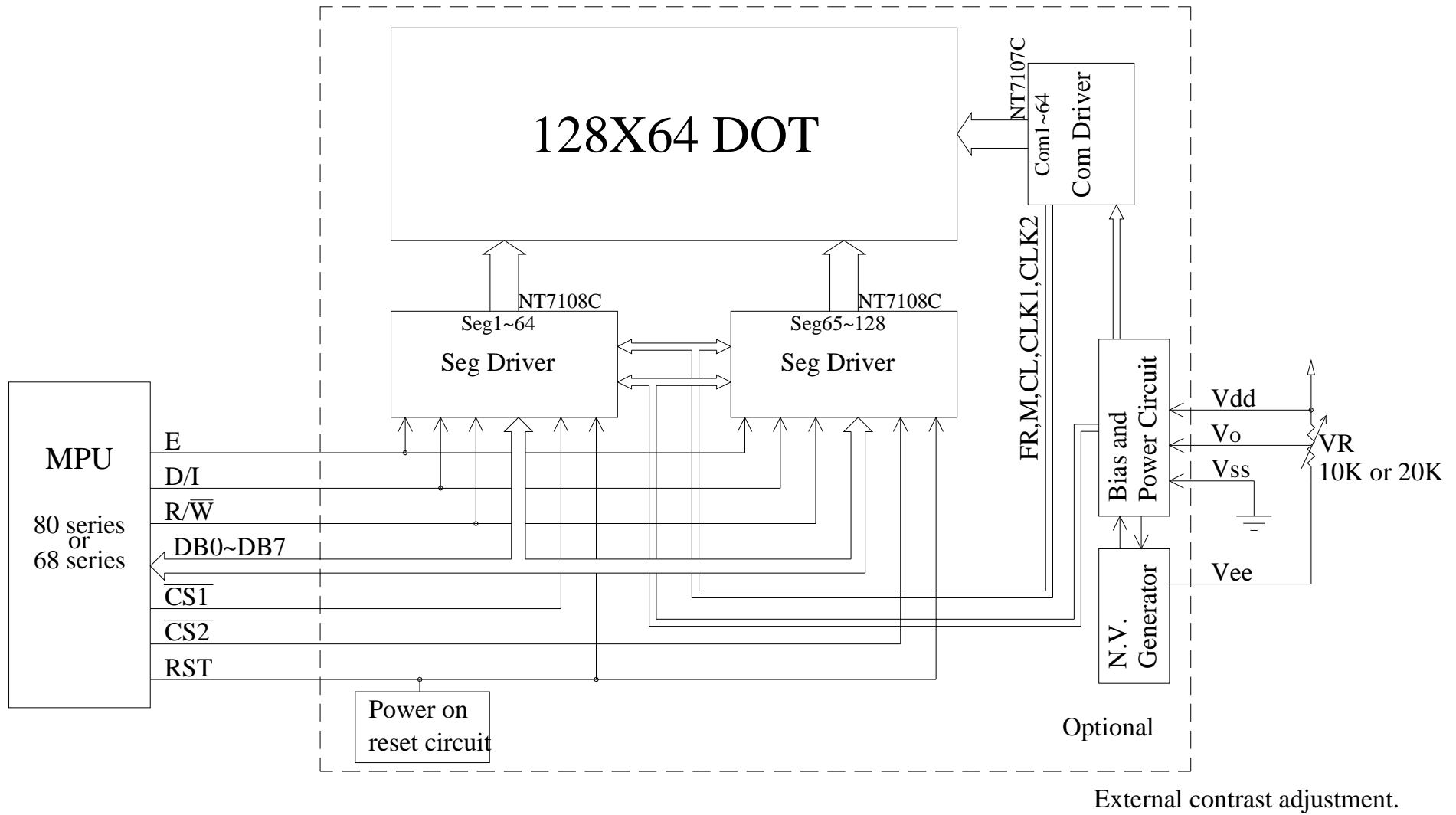

# 9. Timing Characteristics

MPU Interface

(T=25°C, VDD=+5.0V±0.5)

Characteristic	Symbol	Min	Typ	Max	Unit
E cycle	t <sub>cy</sub>	1000	-	-	ns
E high level width	t <sub>whE</sub>	450	-	-	ns
E low level width	t <sub>wlE</sub>	450	-	-	ns
E rise time	t <sub>r</sub>	-	-	25	ns
E fall time	t <sub>f</sub>	-	-	25	ns
Address set-up time	t <sub>as</sub>	140	-	-	ns
Address hold time	t <sub>ah</sub>	10	-	-	ns
Data set-up time	t <sub>dsw</sub>	140	-	-	ns
Data delay time	t <sub>ddr</sub>	-	-	320	ns
Data hold time (write)	t <sub>dhw</sub>	10	-	-	ns
Data hold time (read)	t <sub>dhr</sub>	20	-	-	ns

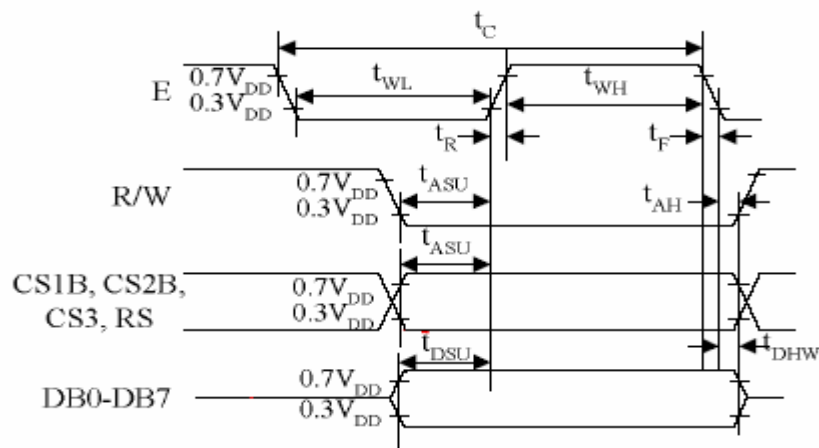

MPU Write Timing

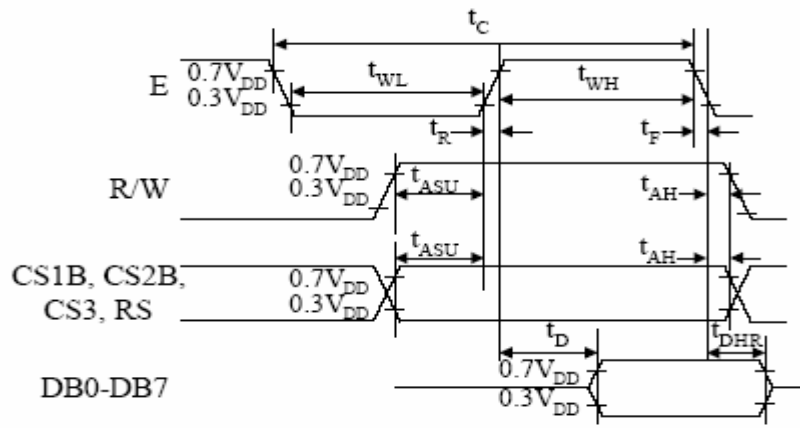

**MPU Read Timing**

# 10.Display Control Instruction

The display control instructions control the internal state of the NT7108. Instruction is received from MPU to NT7108 for the display control. The following table shows various instructions.

Instruction	RS	R/W	DB7	DB6	DB5	DB4	DB3	DB2	DB1	DB0	Function	
Display on/off	L	L	L	L	H	H	H	H	H	L/H	Controls the display on or off. Internal status and display RAM data is not affected. L:OFF, H:ON	
Set address (Y address)	L	L	L	H	Y address (0-63)						Sets the Y address in the Y address counter.	
Set page (X address)	L	L	H	L	H	H	H	Page (0-7)			Sets the X address at the X address register.	
Display Start line (Z address)	L	L	H	H	Display start line (0-63)						Indicates the display data RAM displayed at the top of the screen.	
Status read	L	H	Busy	L	On/Off	Reset	L	L	L	L	Read status. BUSY L: Ready H: In operation ON/OFF L: Display ON H: Display OFF RESET L: Normal H: Reset	
Write display data	H	L	Write data									Writes data (DB0: 7) into display data RAM. After writing instruction, Y address is increased by 1 automatically.
Read display data	H	H	Read data									Reads data (DB0: 7) from display data RAM to the data bus.

# 11.Detailed Explanation

RS	R/W	DB7	DB6	DB5	DB4	DB3	DB2	DB1	DB0
0	0	0	0	1	1	1	1	1	D

The display data appears when D is 1 and disappears when D is 0. Though the data is not on the screen with D=0, it remains in the display data RAM. Therefore, you can make it appear by changing D=0 into D=1.

## SET ADDRESS (Y ADDRESS)

RS	R/W	DB7	DB6	DB5	DB4	DB3	DB2	DB1	DB0
0	0	0	1	AC5	AC4	AC3	AC2	AC1	AC0

Y address (AC0-AC5) of the display data RAM is set in the Y address counter. An address is set by instruction and increased by 1 automatically by read or write operations of display data.

## SET PAGE (X ADDRESS)

RS	R/W	DB7	DB6	DB5	DB4	DB3	DB2	DB1	DB0
0	0	1	0	1	1	1	AC2	AC1	AC0

X address (AC0-AC2) of the display data RAM is set in the X address register. Writing or reading to or from MPU is executed in this specified page until the next page is set.

## DISPLAY START LINE (Z ADDRESS)

RS	R/W	DB7	DB6	DB5	DB4	DB3	DB2	DB1	DB0
0	0	1	1	AC5	AC4	AC3	AC2	AC1	AC0

Z address (AC0-AC5) of the display data RAM is set in the display start line register and displayed at the top of the screen. When the display duty cycle is 1/64 or others (1/32-1/64), the data of total line number of LCD screen, from the line specified by display start line instruction, is displayed.

## STATUS READ

RS	R/W	DB7	DB6	DB5	DB4	DB3	DB2	DB1	DB0
0	1	BUSY	0	ON/OFF	RESET	0	0	0	0

### BUSY

When BUSY is 1, the Chip is executing internal operation and no instructions are accepted.

When BUSY is 0, the Chip is ready to accept any instructions.

### ON/OFF

When ON/OFF is 1, the display is OFF.

When ON/OFF is 0, the display is ON.

### RESET

When RESET is 1, the system is being initialized.

In this condition, no instructions except status read can be accepted.

When RESET is 0, initializing has finished and the system is in usual operation condition.

## WRITE DISPLAY DATA

RS	R/W	DB7	DB6	DB5	DB4	DB3	DB2	DB1	DB0
1	0	D7	D6	D5	D4	D3	D2	D1	D0

Writes data (D0-D7) into the display data RAM. After writing instruction, Y address is increased by 1 automatically.

## READ DISPLAY DATA

RS	R/W	DB7	DB6	DB5	DB4	DB3	DB2	DB1	DB0
1	1	D7	D6	D5	D4	D3	D2	D1	D0

Reads data (D0-D7) from the display data RAM. After reading instruction, Y address is increased by 1 automatically.

# 12.RELIABILITY

## Content of Reliability Test (wide temperature, -20°C~70°C)

Environmental Test			
Test Item	Content of Test	Test Condition	Note
High Temperature storage	Endurance test applying the high storage temperature for a long time.	80°C 200hrs	2
Low Temperature storage	Endurance test applying the high storage temperature for a long time.	-30°C 200hrs	1,2
High Temperature Operation	Endurance test applying the electric stress (Voltage & Current) and the thermal stress to the element for a long time.	70°C 200hrs	—
Low Temperature Operation	Endurance test applying the electric stress under low temperature for a long time.	-20°C 200hrs	1
High Temperature/ Humidity Operation	The module should be allowed to stand at 60 °C,90%RH max For 96hrs under no-load condition excluding the polarizer, Then taking it out and drying it at normal temperature.	60°C,90%RH 96hrs	1,2
Thermal shock resistance	The sample should be allowed stand the following 10 cycles of operation <div style="text-align: center;"> <p>-20°C    25°C    70°C</p> <p>30min    5min    30min</p> <p>1 cycle</p> </div>	-20°C/70°C 10 cycles	—
Vibration test	Endurance test applying the vibration during transportation and using.	Total fixed amplitude : 1.5mm Vibration Frequency : 10~55Hz One cycle 60 seconds to 3 directions of X,Y,Z for Each 15 minutes	3
Static electricity test	Endurance test applying the electric stress to the terminal.	VS=800V,RS=1.5k CS=100pF 1 time	—

**Note1: No dew condensation to be observed.**

**Note2: The function test shall be conducted after 4 hours storage at the normal Temperature and humidity after remove from the test chamber.**



**Note3: Vibration test will be conducted to the product itself without putting it in a container.**

# 13.Backlight Information

PARAMETER	SYMBOL	MIN	TYP	MAX	UNIT	TEST CONDITION
Supply Current	ILED	57.6	64	100	mA	V=3.5V
Supply Voltage	V	3.4	3.5	3.6	V	
Reverse Voltage	VR	-	-	5	V	
Luminous Intensity	IV	282	344	-	CD/M <sup>2</sup>	ILED=64mA
LED Life Time (For Reference only)		-	50K	-	Hr.	ILED 64mA 25°C,50-60%RH, (Note 1)
Color	White					

**Note:** The LED of B/L is drive by current only, drive voltage is for reference only.

drive voltage can make driving current under safety area (current between minimum and maximum).

**Note1 :**50K hours is only a estimate for reference.

.Drive from pin19,pin20

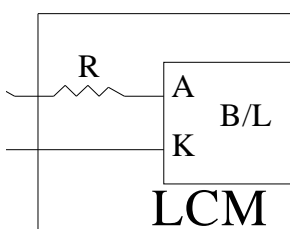

# 14. Inspection specification

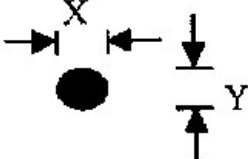
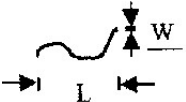
NO	Item	Criterion	AQL													
01	Electrical Testing	1.1 Missing vertical, horizontal segment, segment contrast defect. 1.2 Missing character , dot or icon. 1.3 Display malfunction. 1.4 No function or no display. 1.5 Current consumption exceeds product specifications. 1.6 LCD viewing angle defect. 1.7 Mixed product types. 1.8 Contrast defect.	0.65													
02	Black or white spots on LCD (display only)	2.1 White and black spots on display 0.25mm, no more than three white or black spots present. 2.2 Densely spaced: No more than two spots or lines within 3mm	2.5													
03	LCD black spots, white spots, contamination (non-display)	3.1 Round type : As following drawing  <table border="1" data-bbox="874 920 1358 1429"> <tr><td></td><td></td></tr> <tr><td></td><td></td></tr> <tr><td></td><td></td></tr> <tr><td></td><td></td></tr> <tr><td></td><td></td></tr> </table>											2.5			
3.2 Line type : (As following drawing)  <table border="1" data-bbox="710 1467 1358 1733"> <thead> <tr> <th>Length</th> <th>Width</th> <th>Acceptable Q TY</th> </tr> </thead> <tbody> <tr> <td>---</td> <td>W</td> <td>Accept no dense</td> </tr> <tr> <td>L</td> <td>0.02 W</td> <td rowspan="2">2</td> </tr> <tr> <td>L</td> <td>0.03 W</td> </tr> <tr> <td>---</td> <td>0.05 W</td> <td>As round type</td> </tr> </tbody> </table>		Length	Width	Acceptable Q TY	---	W	Accept no dense	L	0.02 W	2	L	0.03 W	---	0.05 W	As round type	2.5
Length	Width	Acceptable Q TY														
---	W	Accept no dense														
L	0.02 W	2														
L	0.03 W															
---	0.05 W	As round type														

04	Polarizer bubbles	If bubbles are visible, judge using black spot specifications, not easy to find, must check in specify direction.	Size	Acceptable Q TY	2.5
				Accept no dense	
				3	
				2	
				0	
			Total Q TY	3	

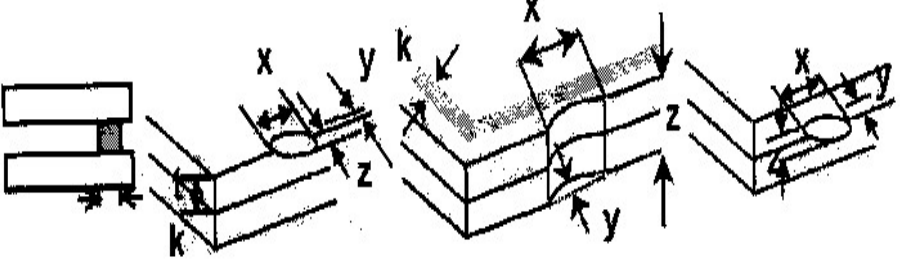
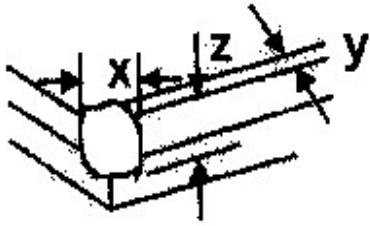
NO	Item	Criterion	AQL																		
05	Scratches	Follow NO.3 LCD black spots, white spots, contamination																			
06	Chipped glass	<p>Symbols Define:  x: Chip length      y: Chip width      z: Chip thickness  k: Seal width      t: Glass thickness      a: LCD side length  L: Electrode pad length:</p> <p>6.1 General glass chip :  6.1.1 Chip on panel surface and crack between panels:</p>  <table border="1" data-bbox="419 898 1345 1126"> <tr> <td>: C</td> <td>: C</td> <td>: C</td> </tr> <tr> <td></td> <td></td> <td></td> </tr> <tr> <td></td> <td></td> <td></td> </tr> </table> <p>C :</p>  <table border="1" data-bbox="419 1576 1345 1805"> <tr> <td>: C</td> <td>: C</td> <td>: C</td> </tr> <tr> <td></td> <td></td> <td></td> </tr> <tr> <td></td> <td></td> <td></td> </tr> </table>	: C	: C	: C							: C	: C	: C							2.5
: C	: C	: C																			
: C	: C	: C																			

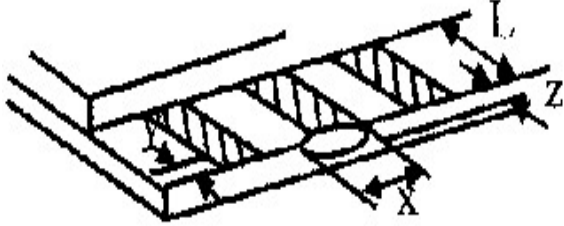
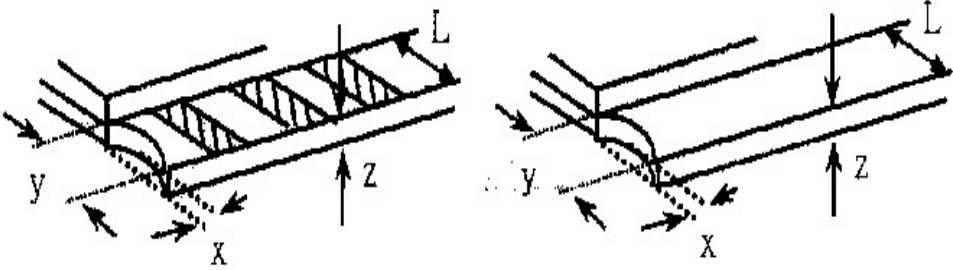
NO	Item	Criterion	AQL												
06	Glass crack	<p style="text-align: center;">:</p> <p>x: Chip length      y: Chip width      z: Chip thickness  k: Seal width      t: Glass thickness      a: LCD side length  L: Electrode pad length</p> <p>6.2 Protrusion over terminal :</p> <p>6.2.1 Chip on electrode pad :</p>  <table border="1" data-bbox="336 853 1249 1025"> <tr> <td style="text-align: center;">: C</td> <td style="text-align: center;">: C</td> <td style="text-align: center;">: C</td> </tr> <tr> <td> </td> <td> </td> <td> </td> </tr> </table> <p style="text-align: center;">-</p>  <table border="1" data-bbox="408 1424 1249 1682"> <tr> <td style="text-align: center;">: C</td> <td style="text-align: center;">: C</td> <td style="text-align: center;">: C</td> </tr> <tr> <td style="text-align: center;">L</td> <td> </td> <td> </td> </tr> </table>	: C	: C	: C				: C	: C	: C	L			2.5
: C	: C	: C													
: C	: C	: C													
L															

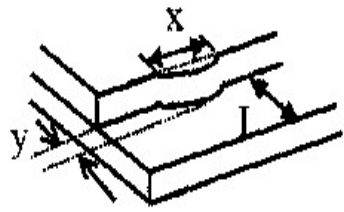

:	:
L	

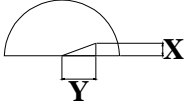
NO	Item	Criterion	AQL
07	Cracked glass	LCD	2.5
08	Backlight elements	LCD	0.65 2.5 0.65
09	Bezel		2.5 0.65
10	PCB COB	<p>C</p> <p>C</p> <p>C</p> <p>The height of the COB should not exceed the height indicated in the assembly diagram.</p> <p>10.4 There may not be more than 2mm of sealant outside the seal area on the PCB. And there should be no more than three places.</p> <p>10.5 No oxidation or contamination PCB terminals.</p> <p>10.6 Parts on PCB must be the same as on the production characteristic chart. There should be no wrong parts, missing parts or excess parts.</p> <p>10.7 The jumper on the PCB should conform to the product characteristic chart.</p> <p>10.8 If solder gets on bezel tab pads, LED pad, zebra pad or screw hold pad, make sure it is smoothed down.</p> <p>10.9 The Scraping testing standard for Copper Coating of PCB</p>  <p><math>X * Y \leq 2\text{mm}^2</math></p>	2.5 2.5 0.65 2.5 2.5 0.65 2.5 2.5 0.65
11	Soldering	-	2.5 2.5 2.5 0.65



NO	Item	Criterion	AQL
12	General appearance		2.5
		L C	
		L C	0.65
			2.5
			2.5
		C C	2.5
			2.5
			2.5
			0.65
			0.65
		LCD	0.65



# 15. Material List of Components for RoHS

1. WINSTAR Display Co., Ltd hereby declares that all of or part of products (with the mark “#”in code), including, but not limited to, the LCM, accessories or packages, manufactured and/or delivered to your company (including your subsidiaries and affiliated company) directly or indirectly by our company (including our subsidiaries or affiliated companies) do not intentionally contain any of the substances listed in all applicable EU directives and regulations, including the following substances.

Exhibit A : The Harmful Material List

Material	(Cd)	(Pb)	(Hg)	(Cr6+)	PBBs	PBDEs
Limited Value	100 ppm	1000 ppm	1000 ppm	1000 ppm	1000 ppm	1000 ppm
Above limited value is set up according to RoHS.						

2.Process for RoHS requirement :

(1) Use the Sn/Ag/Cu soldering surface the surface of Pb-free solder is rougher than we used before.

(2) Heat-resistance temp. :

Reflow : 250□,30 seconds Max.

Connector soldering wave or hand soldering : 320□, 10 seconds max.

(3) Temp. curve of reflow, max. Temp. : 235±5□

Recommended customer’s soldering temp. of connector : 280□, 3 seconds.





## LCM Sample Estimate Feedback Sheet

Page: 1

1. Panel Type : Pass NG , \_\_\_\_\_
2. View Direction : Pass NG , \_\_\_\_\_
3. Numbers of Dots : Pass NG , \_\_\_\_\_
4. View Area : Pass NG , \_\_\_\_\_
5. Active Area : Pass NG , \_\_\_\_\_
6. Operating Temperature : Pass NG , \_\_\_\_\_
7. Storage Temperature : Pass NG , \_\_\_\_\_
8. Others : \_\_\_\_\_

### **2 Mechanical Specification :**

1. PCB Size : Pass NG , \_\_\_\_\_
2. Frame Size : Pass NG , \_\_\_\_\_
3. Material of Frame : Pass NG , \_\_\_\_\_
4. Connector Position : Pass NG , \_\_\_\_\_
5. Fix Hole Position : Pass NG , \_\_\_\_\_
6. Backlight Position : Pass NG , \_\_\_\_\_
7. Thickness of PCB : Pass NG , \_\_\_\_\_
8. Height of Frame to PCB : Pass NG , \_\_\_\_\_
9. Height of Module : Pass NG , \_\_\_\_\_
10. Others : Pass NG , \_\_\_\_\_

### **3 Relative Hole Size :**

1. Pitch of Connector : Pass NG , \_\_\_\_\_
2. Hole size of Connector : Pass NG , \_\_\_\_\_
3. Mounting Hole size : Pass NG , \_\_\_\_\_
4. Mounting Hole Type : Pass NG , \_\_\_\_\_
5. Others : Pass NG , \_\_\_\_\_

### **4 Backlight Specification :**

1. B/L Type : Pass NG , \_\_\_\_\_
2. B/L Color : Pass NG , \_\_\_\_\_
3. B/L Driving Voltage (Reference for LED Type) : Pass NG , \_\_\_\_\_
4. B/L Driving Current : Pass NG , \_\_\_\_\_
5. Brightness of B/L : Pass NG , \_\_\_\_\_
6. B/L Solder Method : Pass NG , \_\_\_\_\_
7. Others : Pass NG , \_\_\_\_\_

**Go to page 2**

**5 Electronic Characteristics of**

**Module :**

---

- |                              |      |            |
|------------------------------|------|------------|
| 1. Input Voltage :           | Pass | NG , _____ |
| 2. Supply Current :          | Pass | NG , _____ |
| 3. Driving Voltage for LCD : | Pass | NG , _____ |
| 4. Contrast for LCD :        | Pass | NG , _____ |
| 5. B/L Driving Method :      | Pass | NG , _____ |
| 6. Negative Voltage Output : | Pass | NG , _____ |
| 7. Interface Function :      | Pass | NG , _____ |
| 8. LCD Uniformity :          | Pass | NG , _____ |
| 9. ESD test :                | Pass | NG , _____ |
| 10. Others :                 | Pass | NG , _____ |

**6 Summary :**

**Sales signature :** \_\_\_\_\_

**Customer Signature :** \_\_\_\_\_

**Date :** \_\_\_\_ / \_\_\_\_ / \_\_\_\_