

PRODUCT NO.
SEE TABLE

ULTRASONIC WELD AREA
NOTE 6
MFG SITE CODE

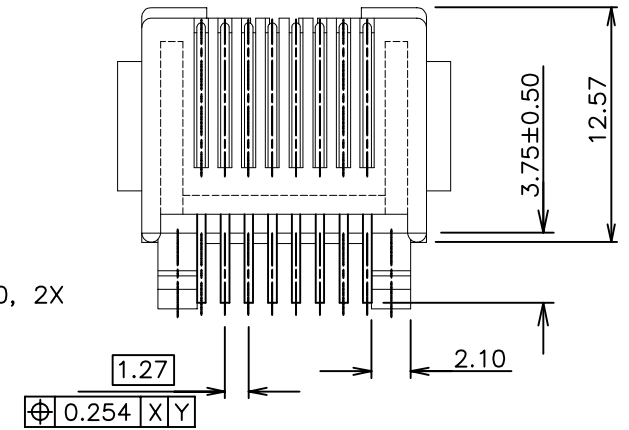
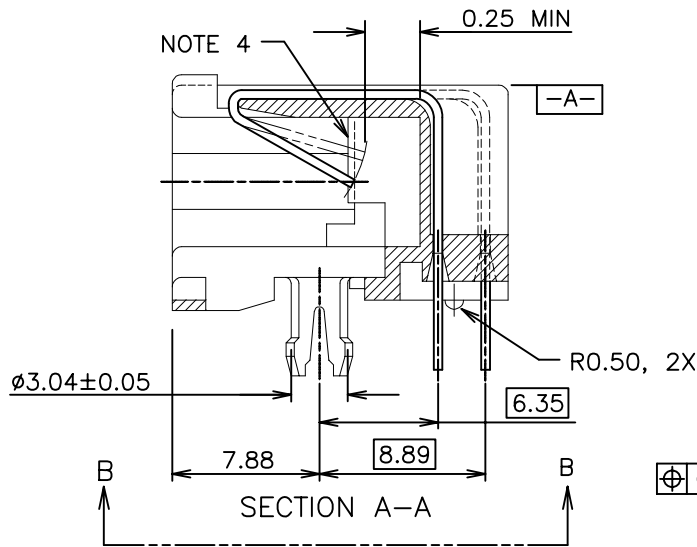
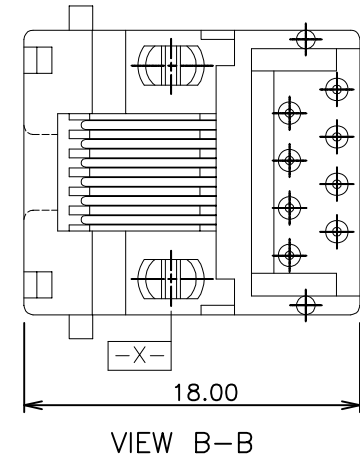
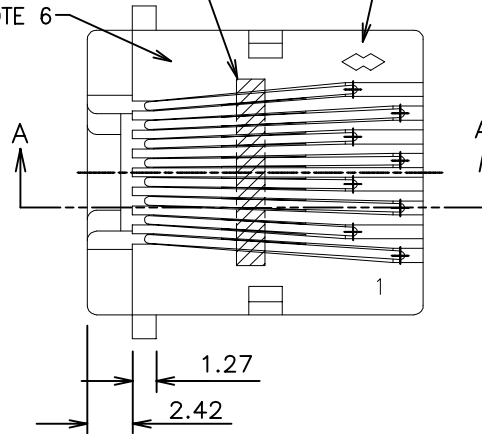
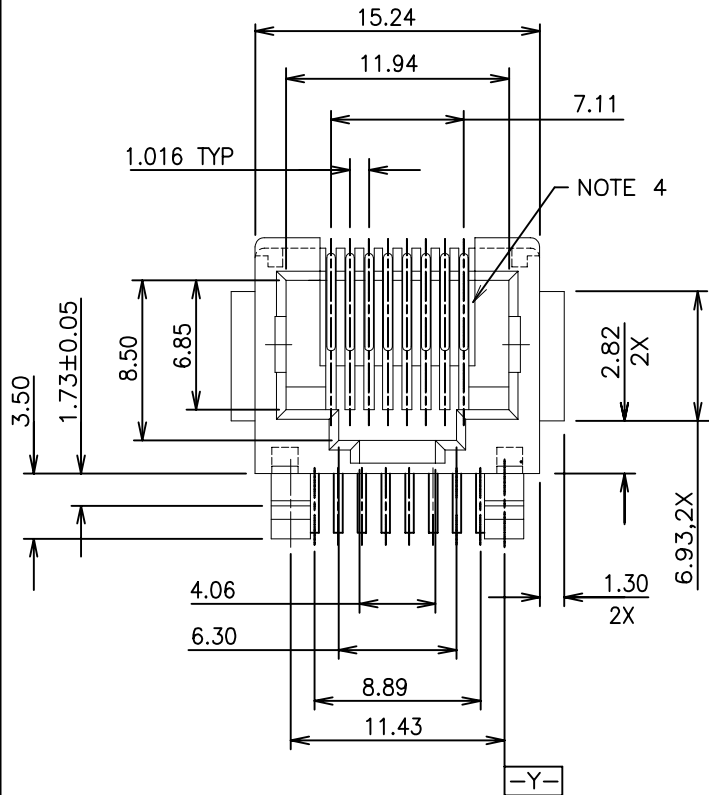

mat'l. code		surface		tolerance		projection		product family	
		ISO1302		ISO1101 ISO406		mm		MOD JACK	
ltr		ecn no		dr		date		title	
H		ELX-N-16190		Henry		11/01/13		MODIFIED LOW PROFILE PCB III	
-		-		-		-		HORZ MOD JCAK FOR 1.66mm P.C.B	
C		V60576		GAH		03/22/96		scale 1.0	
D		T00076		BKB		3/30/00		FCI	
E		V00698		CSP		4/18/00		sheet, 1 of 2	
F		V03-1103		PJ		10/22/03		94908	
G		V05-0187		LP		3/23/05		type Product Customer Drawing	
sheet		revision		H					
index		sheet		1					

PRODUCT NUMBER	NO. OF POS	LOADED POSITION
94908-X88	8	ALL POS.
94908-X86		2,3,4,5,6,7
94908-X84		3,4,5,6
94908-X84A		1,2,3,6
94908-X88LF	8	ALL POS.
94908-X86LF		2,3,4,5,6,7
94908-X84LF		3,4,5,6
94908-X84ALF		1,2,3,6

NOTE: PLEASE CHECK FOR AVAILABILITY, NOT ALL OPTIONS AVAILABLE.

PLATING CODE	PLATING	HSG COLOR
0	5u" Au + high performance lubricant	BLACK
1	15μ" AU	
2	20μ" GFPD	
3	30μ" AU	
4	15μ" G.X.T	
5	50μ" AU	

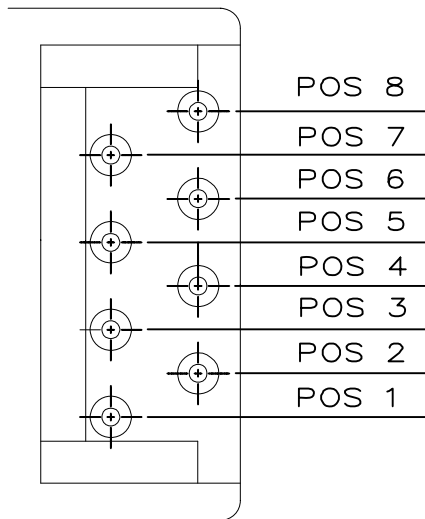

WIRE POSITION No

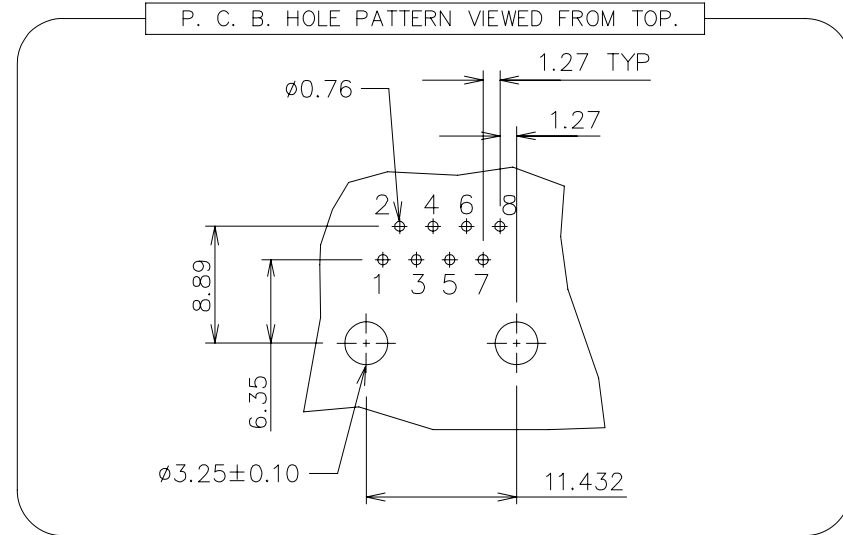

NOTES:

- RECOMMENDED P.C.B THICKNESS 1.60 MM
- HOUSING MAT'L: NYLON 66, 25% GLASS REINFORCED, UL94-V0, COLOR : SEE TABLE.
THE HOUSING WILL WITHSTAND EXPOSURE TO 260 DEGREES C PEAK TEMPERATURE FOR 10 SECONDS IN A WAVE SOLDER APPLICATION WITH A 1.60mm MIN THICK CIRCUIT BOARD.
- CONTACTS: PHOS BRONZE ALLOY UNS-C51000, 0.460 DIA. ROUND WIRE. SEE TABLE FOR PLATING.
- PROTRUDED SHELF ONLY APPEARS ON 8-POS JACK.
- STANDARD PACKAGING METHOD (USE TUBE): SEE GES-14-361. PACKAGING OF LEAD FREE PRODUCTS MEETS LABELING AND PACKAGING SPECIFICATION GS-14-920.
- COMPANY LOGO LOCATED IN THIS AREA ,AND WOULD APPEAR IN THE SAME SHIPMENT UNLESS LOGO SPEC HEREIN IS UPDATED.
- LEAD FREE PRODUCTS MEET EUROPEAN UNION DIRECTIVES AND OTHER COUNTRY REGULATIONS AS DESCRIBED IN GS-22-008.

mat'l. code		surface ISO1302		tolerance ISO1101 ISO406		projection		product family MOD JACK	
ltr		ecn no		dr		date		title	
H								MODIFIED LOW PROFILE PCB III	
								HORZ MOD JCAK FOR 1.60mm P.C.B	
								dwg no 94908	
								sheet, 2 of 2	
								size A4	
								type Product Customer Drawing	
sheet index		revision sheet		H					
1		1							